

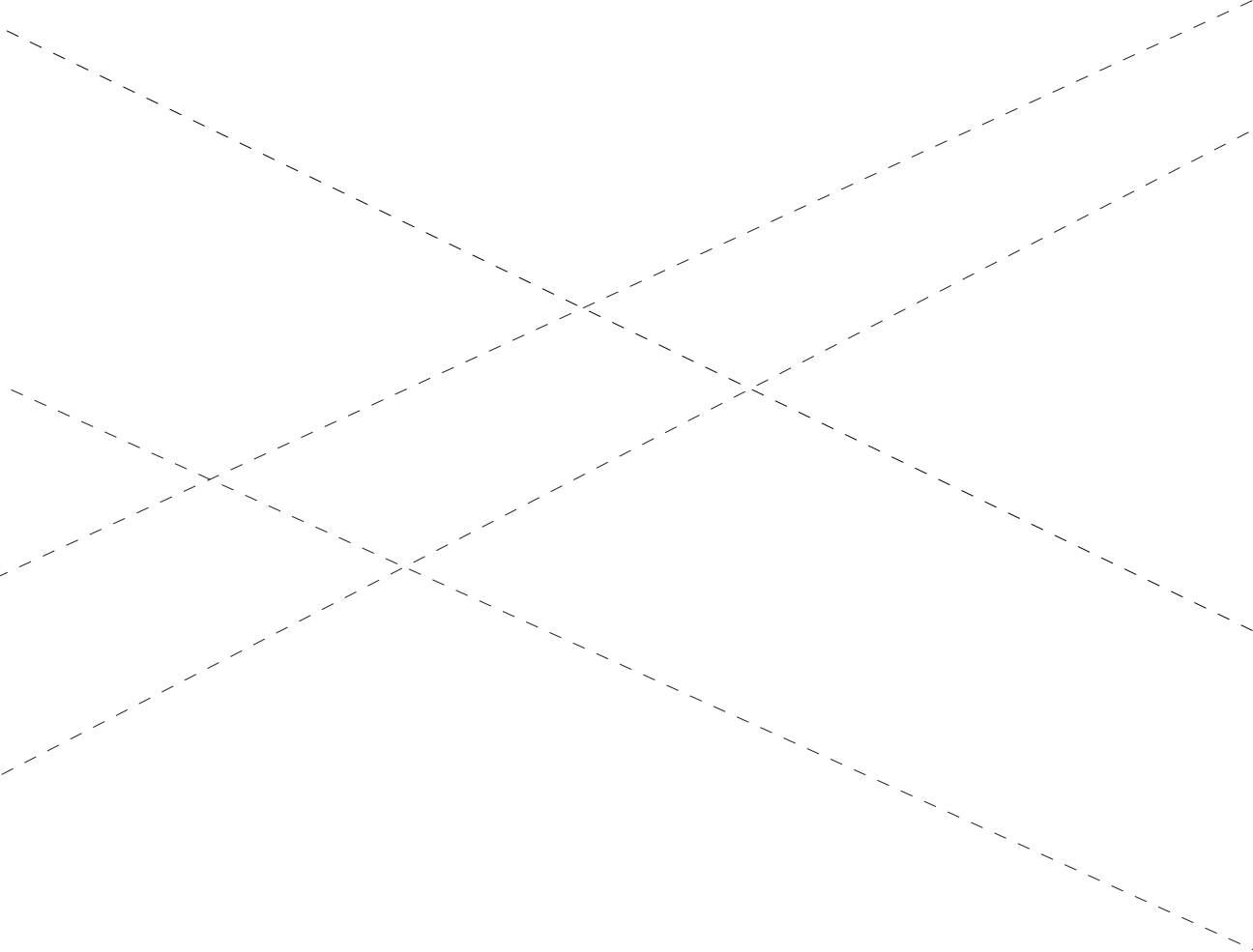

volume II
university of tennessee
college of architecture + design
2007-2008

current

current





contributors



dean

john mcrae

student staff

catherine abbott

ashley bigham

bonnie casamassima

ryan flener

samuel mortimer

andy ruff

stephen townsend





dean's prologue	5
student perspective	7
trey trahan interview	8
elizabeth meyer interview	13
student work	22
first year	
second year	
third year	
fourth year	
self directed project	
graduate	
interior design	
study abroad	88
lecture series 2007 - 2008	90
awards and scholarships	92



dean's prologue



We are honored to provide for the design community this second edition of CURRENT, the student organized and edited publication of the College of Architecture and Design. This outstanding cross section of studio projects comes from all levels and all disciplines, together with interviews with professionals prominent in their fields, as well as work from the foreign studies programs.

Our students and faculty are presently engaged in active collaboration and exploration on the topic of "Studio Culture." What is it? How can it be strengthened? How can it foster critical thinking and dialogue? This work is a manifestation of the thoughtful creative response that can be achieved through a healthy studio environment, committed faculty and creative students. The work clearly represents an incredible level of energy and passion, combined with the skills that prepare our students for their engagement in practice.

Design process, of course, involves simultaneous abilities and multiple steps. In particular, it is clear from this work that, aside from the creative nature of the solutions themselves, the students in the College are very accomplished and comfortable with a full range of graphic representation, including hand drawings, digital models and other means, to demonstrate the power of the work and how materials, technology and space planning all play a part in conveying meaning.

This is the second edition of many to come, and we thank you for taking the time to review CURRENT. Next year's CURRENT will include the work of our newest program, the Master of Landscape Architecture, which started this fall. The students who are now "in the pipeline," along with those to come, are facing challenging times that are filled with opportunities for engaging the needs of the built environment. We are confident that the students of the College are prepared to meet these demands, and the work displayed in CURRENT is certainly a clear indication. Enjoy!

John McRae, FAIA
Dean, College of Architecture and Design



Welcome to the second edition of CURRENT, the student-work compilation for the College of Architecture and Design at the University of Tennessee. We bring you this edition at a critical time in history: the polar ice caps are melting at an astounding rate, global economies are crumbling, and the United States is in the middle of an energy crisis. As young designers about to enter the professional world, we see these problems as opportunities for our generation. At the University of Tennessee, not only are students more environmentally, socially, and economically aware of the current state of the world than ever before – we are eager to fix it.

While the world around us is changing, the College of Architecture and Design still identifies design as the core of all curriculum. Beginning in first year studio, students are taught basic design skills of composition and craft. During the next few years, students build and develop these skills with the guidance of faculty. The College encourages the growth of every student to pursue his or her own interests. This personal growth is exemplified each year by the thesis projects produced from fifth year undergraduate and second and third year graduate students. Supported by history, theory, technology, and self-directed courses, students graduate with a strong foundation required for a lifetime of learning in the professional field.

Within the past year, by a unanimous vote of the faculty, the College of Architecture and Design has adopted a plan to achieve a carbon-neutral design community and include the elimination or reduction of the need for fossil fuel as a central tenet in its design education. All courses from history to technology will consider the interface between energy, building, and the environment. The student body has welcomed this change. Third year students continue to collaborate each spring with Oak Ridge National Laboratory to design zero energy homes and currently a multi-disciplinary effort is being led by students to design and install a green roof on the Art + Architecture building in the near future.

It is our opinion that there has never been a better time to be young designers. Devoted and equipped, we are more than willing to face the challenges of today's world. It is with these attitudes in mind that we present the second edition of CURRENT.

Samuel Mortimer
Fourth Year Undergraduate Architecture Student

Ashley Bigham
Fifth Year Undergraduate Architecture Student



trey trahan interview

personal interview. march 3, 2008

CURRENT: To start off, you received your bachelors of architecture from Louisiana State University and you are the president and principal-in-charge of Trahan Architects. What inspired your interest in architecture?

TREY TRAHAN: I was a really poor student in my early elementary and high school years, and an art teacher in high school actually picked up on my interest in architecture. I think it came from my mother because I was always building things, and for Christmas asking for power tools instead of the normal kid stuff. This Mr. East took it upon himself as an art teacher to share a number of exercises in art school that really intrigued me and I did well. I guess that, coupled with always building things. I was always taking discarded lumber from building sites in the neighborhood and building things in the backyard. I did well in that art class and then went to LSU, and anytime you're a little ahead of everybody else you excel and people look to you for advice and it builds confidence within yourself, and you build on that. I think it was that simple.

CURRENT: In both your educational and professional practice, you have established a strong bond with Baton Rouge and the state of Louisiana. How does your familiarity with this unique cultural context reveal itself in your work?

TREY TRAHAN: That's a good question. Most people in Louisiana, I won't say all, but a lot of people are, not embarrassed of the state, but it ranks so low in all the things you want to be high in, and the educational system is not the highest. I guess, and this is what's been nice about getting a little older, you start realizing the beauty of place and it's not always about health care, education, all that, but sometimes there's something so naturally unique and beautiful that it takes time to appreciate. I think that's the most exciting part about this time in my life, realizing that, although we would never promote a society not advancing, sometimes, out of a lack of advancement, it allows for some really beautiful things to remain that you can retreat to or build upon. I think that's a unique benefit that comes out of the lack of advancement in Louisiana, and we were just speaking about that.

We were just selected for our first museum, and it's in Natchitoches, Louisiana, which is in the Northern portion. It was the earliest settlement in the Louisiana Purchase Territory, and some of the earliest structures are made of bousiage. I'm not sure if you are familiar with bousiage. Bousiage, which made up the oldest buildings, were loaves. They would actually dig holes, set timbers vertical in the ground, and then take the loaves of clay, horse hair, and moss and stack them in between the timbers. They're still standing, many of those structures today. They're beautiful because the clay would dry and crack, and if you're in North Louisiana, it has a peakish hue, which is the reddish hue which is really beautiful. If you're in South Louisiana, it has a brownish hue. I think those things, and all the other things that

respond to everything from the shotgun house in New Orleans, with that movement of air to elevate the structure and the large roof for sun protection. For us, we don't want to repeat those things, but we want our work to be historically connected. How do we do that in a beautiful way, and what does that mean to the way we live and work today? I think that we do make those connections to times past and we sense that there is at times a lack of authenticity in things, people, buildings. I don't know if we've captured those unique things to Louisiana, but it's an important part to our architecture, finding those things.

CURRENT: The proximity to New Orleans obviously plays a part in your architecture, so does a catastrophic event such as Hurricane Katrina affect your view of architecture, and if it does, how does it affect your approach to design in that context?

TREY TRAHAN: It has affected us in a number of ways. We were the architects for the Superdome after Katrina, which was a ridiculous project in the sense that it was \$200 million dollars of renovation right after Katrina, which begs to question political decisions as they relate to catastrophe. That the governor, the NFL, and other state leaders would choose to restore a sporting venue when there are hospitals that have been totally decimated gave us some sense of the situation and you begin to question priorities. It ended up a tremendously successful project because it did, believe it or not, restore to so many of the people a belief that the city could come back. That was terribly important.

If you're familiar with the wetlands of Louisiana, before the levees the Mississippi would restore the wetlands, they were constantly feeding soils and maintaining the marshes, and so there were 70 to 80 miles of marshland from the edge of the coast to New Orleans. When they built the levees, what it did, obviously, was force all that soil from up North, that sediment, through the mouth, and so the marshes are now about 30 miles less than they originally were. As you can appreciate, land mass dissipates wind forces, which affects a city. It reminds us why we should design respectful of nature and with an understanding that, eventually, nature will win, as in this case. A gentleman named Harold Fisk documented the ancient meanders, some of it is interpretive, of the Mississippi River, which gives you a sense of the movement of the river, not only in Louisiana but in the Northern states, and its impact on various issues of how we build and political issues. For example, at one time a small island in the Mississippi was on the Louisiana side and, as the river began to deposit and spread soils, it moved to the Mississippi side. There are all kinds of stories about the effects of the river. I think Katrina is about understanding nature, and we question the Corps' decision to levy off a city. Of course, the other question is how those early settlers had the basic primitive instinct to build on highlands and how people in recent years have built where you should never build.

CURRENT: As architects and the media have given special attention to the rebuilding of New Orleans, does this help or hurt the revitalization and redesign of these neighborhoods?

TREY TRAHAN: I think it does. I think it forces many things, issues that people have for years put aside, to address them, where we should build. Although we're participating in a project right now which I find exciting in some ways, some have questioned it: Brad Pitt's Make it Right project, where he chose thirteen architects to help rebuild the Ninth Ward. The question that we were asked there is should you really build back in that low-lying land, and I think you can. The Corps has assured everybody that it is safe, but it's interesting in that you take a person with that type of recognition and you bring to it residents who have never worked with architects and those types of relationships begin to occur that can begin to create a residential architecture that is appropriate to addressing the problems. They repeated the shotgun house and many of those typologies all over New Orleans, whether it was in the highlands or the lowlands without some sensitivity for modifying those structures for the uniqueness of that context. I think that's what this is bringing out, that a structure is so connected to those unique conditions, and we should build respectful of them.

CURRENT: In recent years, your firm has received several acclaimed awards in recognition of outstanding design. Do you believe these accolades have allowed you more freedom to pursue projects with unique opportunities or challenges?

TREY TRAHAN: I think that they bring many wonderful things, many positive things, but they also bring some criticism. Receiving awards is nice for obvious reasons, and the publications are nice. It's intriguing to me as a firm in South Louisiana, the emails we still receive over some projects that have won awards years ago. Last week in the office my secretary showed me from a magazine in the Ukraine wanting to do a story on us, and you question: how does that happen? It's wonderful that you get those calls, and I thought it would have resulted in more work, but you realize that most of these magazines are read by architects and not many clients; we're kind of feeding ourselves. Of course, we all want to receive recognition, and it's been nice that you then get to serve on juries and I was on the National AIA jury a couple years ago for architecture, and it allows you to see what other great work architects are doing around the country.

The connections that it creates are never what I think you think they're going to be, they're always strange connections. I've found that the impact on our business has come more out of lectures. I gave a lecture at Yale a few months ago and we've probably received three calls for work, one in Toronto, a cathedral, we're shortlisted for a large Presbyterian church in downtown Colorado Springs, and then another project at Stanford. We'll continue to submit for awards, and we like to get them. Who doesn't? I guess they will always be important to us, they're nice little pieces of paper, and it's nice that people you respect acknowledge your work.

CURRENT: Your increasing international scope of work brings new cultural and social contexts into the influence of your work. How do you maintain quality design while respecting these cultural cues?

TREY TRAHAN: That's an incredible question, it's terribly important. I think the process of designing and building teaches you that there are things imbedded in all environments, whether they're social or cultural, that we think we understand, and we think we see, but I'm convinced that only time allows us to understand them. With that said, I'm fearful of that, candidly. It was interesting on the Make it Right project, the architects from out of the country, what they created thinking it was appropriate to New Orleans, through their eyes as compared to those of us from the area. Some did extremely well, and some, as they went through the process, began to learn that some of the things they picked up were not unique to the Ninth Ward, they were unique to the French Quarter, and you don't see those things. A lot of great things are born out of fear, and I'm fearful that I'll create something in a different place that is elementary and almost insulting to the people in that place, and so with that, we are committed to collaborations.

I don't know if this is true of most architects, but I always wanted to control things. I believe that architects, to some degree, are control freaks and we want to create great art. In the past I would work with clients in a way that I would meet with them but want to then listen to their thoughts and feelings and desires and goals and objectives, but then sit them aside and then meet with engineers, and keep the parties separate in fear that bringing all those unique ingredients together was not manageable. It's nice to arrive at a point in your career where, and I hope that I'm not overly confident, you know that there's a tremendous richness in bringing almost all parties to the table, so to speak, not fearing where it will take you, and believing that it will result in something that is truly responsive to place, to time. It's new for us, this has just occurred over the past two years, and I think it still requires us as architects to manage and lead, but I am hopeful that it will result in something that is not Louisiana influences relocated to foreign places.

CURRENT: In your opinion, which architects, past or present, have most successfully grasped this concept of reviewing and applying context, and integrating culture into design?

TREY TRAHAN: I don't know if this answers that, but the work I'm most attracted to is Louis Kahn's because there is a way of connecting that is so literal that it seems to me as if it's duplication and lacks advancement, some would argue against that. I love the Kimball Art Museum. I do think that it is unique, it is connected to place and that beautiful site, and it's something that I return to as often as I can. I find there to be just a tremendous, almost hidden richness in that building that is obvious initially on some levels but not on others, and I think that it's important to return and find those little secrets of success in that building.

CURRENT: Would you say that Louis Kahn is an all-around inspiration more than just these contextual issues?

TREY TRAHAN: I love Kahn's work, and it's amazing when you pick up his books on unbuilt work how much he didn't get built, but I think that the pieces he did are so thoughtful, and I like that. I think that it's very responsible.

CURRENT: The title of the lecture you will be presenting tonight is “Defining Local.” How does this theme apply to the work of your firm, and the architecture profession in general?

TREY TRAHAN: I think “Defining Local” in many ways, some of the things we’ve already talked about, but I think that “Defining Local” in a project that might best describe it is a project I will speak of last tonight, is TEA, a little office building, 8,000 square feet. Client comes to us and says, “We’re an environmental engineering company and we’ve read a little bit about your firm, and we think we want you to be our architects, so let’s try this.” So you take a client that’s accustomed to seeing, typically in Baton Rouge in a suburban office environment, a hipped shingle roof with a brick veneer with punched openings with interior corridors that have no real sense of place that is almost oppressive, to me, to work in. To create something to me that is very simple and responsive, is about defining local in many ways. It responds to their desires to capture and use water, is respectful of the environmental issues that they deal with daily, remediation and those types of things, deals with the sunlight of Louisiana, and deals with the importance of each worker and their role in the fabric of the field of this architecture.

Defining local, or redefining local, in the sense that people are, in Louisiana, becoming more open to believing in themselves and believing that we can, as crazy as this sounds, lead the nation in ways. That’s very different in the way people of Louisiana have approached things in the past; they’ve settled for the positions in the charts that I’ve mentioned earlier. Most of us in architecture school talk about designing museums and those buildings that are iconic on those rich sites in an urban fabric, and I think it’s really wonderful that it’s going to be appropriate to the context and really rich experientially in connecting to the landscape and the city. I like that it’s a project where most architects would not have taken it seriously, 8,000 square feet, it’s a small building and the budget’s not that big. We’ve invested the time and the energy, obviously you don’t make any money on a project like this as an architect, to show our community that even something that we think of as typically ordinary, can elevate the quality of the work environment.

CURRENT: Would you say that it’s the people more than the specific physical location that help to define this “local?”

TREY TRAHAN: I think it’s both. I think that people are troubled with things that are unfamiliar to them, and when they see them, they’re not sure what slot to put them in. I think that if the process reveals those connections to the past, there’s a comfort that there’s something that the project and decision making is rooted in that’s appropriate to place, and I think that it’s about people also, and that where people are and things that happen in a state that affect where people’s mindset are. For example, in Louisiana, we’re starting to clean up the ethics in government, and I think that celebrates a renewed belief in quality of life and those things that are important. I think that those connections are there and people begin to believe in things and will take opportunities and seek out risks that they wouldn’t previously or when those changes did not occur.

elizabeth meyer interview

personal interview. april 14, 2008



CURRENT: Your architectural education is in both architecture and landscape architecture. What led you to pursue landscape to such a higher degree?

ELIZABETH MEYER: Well, I'm not sure I was focused on architecture, even though I started out in architecture. By that, I mean, when I was in high school I got really interested in cities. It was in the early seventies. We lived in Norfolk, Virginia, and a lot of the cities we were visiting—like my grandparents' who lived in upstate New York—were in the midst of urban renewal. It just seemed like a crazy thing to someone that didn't know anything about cities. Why is all this energy being spent tearing them down when clearly they seemed to need a totally different response which was investing versus tearing down? So I just wanted to design cities and I didn't know how you did that and so, a friend of my parents' said "you should go to architecture school." So I went to architecture school and while there were aspects of architecture that I really enjoyed, in the mid-seventies I think it was fair to say that most architecture projects, their site was a blank sheet of paper. I just slowly found out about landscape architecture. I didn't come at it because I had an innate love of plants or nature. It was really because I was really fascinated with the complexity of cities, the energy of cities, and I wanted to design the space between the buildings more than the buildings themselves. So I found myself trying planning classes and they seemed too policy oriented and I was frustrated with my architecture classes that seemed to be focused on individual buildings. I suspect if I were in school now I would be happier in architecture because I think architecture programs have become more engaged in broader issues that are both physical and social. But back then, it seemed like the way I was going to be able to deal with this territory that you might call urban design was in a landscape architecture program.

CURRENT: Was that what your B.S. was in, Architecture?

ELIZABETH MEYER: Yes, that's right. I entered in architecture, but I transferred into landscape architecture in my third year.

CURRENT: You worked with Hanna/Olin and consulted with others, Michael Vergason and Michael Van Valkenburgh. What was the experience gained in those offices and how do you see that this is still pulling into your own design work and even more so your own research initiatives?

ELIZABETH MEYER: Well, I had great opportunities in practice you know. In my first year out of grad school I had an unusual opportunity to teach for a year. As much as I enjoyed it – it was at Cornell – I realized that I wasn't going to be as confident as a teacher if I didn't practice, and I was also just eager to see how all those ideas became physical. So before Hanna/Olin, I worked for a large firm, which is now one of the largest firms in the world, EDAW. It had about six offices then, and I was there

because of a very talented person named Michael Vergason. Michael was an architect who became a landscape architect and a small group of people were drawn to work with him in that larger office. They were a new office in D.C., and while I realized I was doing a lot of conceptual work and master planning, I wasn't building. What appealed to me about Hanna Olin and particularly working with Laurie Olin, who I'd known through—well, he was on a few of the reviews when I taught at Cornell—was that I knew that Laurie was really interested in the relationship between conceptual ideas and building. Their firm just had a fantastic grasp on that connection between thinking and making. So I went there on kind-of a contract with Laurie. I said, "I understand that I'm strong in these things, but I want to do this, I really want to learn how to build," and so they were great. They had me working on competitions and doing some conceptual things in the office, but I spent most of my time in the design development, doing contract drawings for a small park in Manhattan, Bryant Park. It was a fabulous experience. The conceptual stuff was done, and it was essentially all the hard work of how do you make sure this doesn't get totally ruined in the process of building and coordinating with civil and structural engineers. The park was on top of an underground library, and so it was quite complicated structurally and technically. So that was an amazing experience, and I know one of the things that happened because of that experience was realizing my interest in theory wasn't antithetical to the practice of building and making. And part of it was Laurie's example. He was the sort of principal that would be in late at night when everyone else was on charette—and back then it was pre-computer--so he would have his prismacolors out just like we would. He would be talking about some philosopher he had just read or art critic, Arthur Danto for instance. So here he was drawing, reading, and the next day he would be red-lining construction drawings. Yes, it was a really fabulous example for me and it allowed me to imagine a different way of teaching once I got out of practice where theory was something that was enabling design, not something that was an escape from that.

My collaborations with Michael [Van Valkenburgh] have been different and wonderful. He was my colleague at Harvard, and then there was a moment when I was teaching at Virginia and he called and asked if I wanted to be on a competition team for Wellesley College, a small women's college in Massachusetts. That came at a time when I was in the thick of conceptualizing a book on modern landscapes. I didn't know much about Wellesley as a campus, and as I studied the landscape, it really changed the way I had to think about this book. Modernism is often thought of as something that comes out of the 1920s or 30s. It is an extension of ideas that comes out of either abstract art or changes in technology or emergency functionalism. But it was clear in this project, during this competition, that there was a different science that was affecting the practice of landscape architecture at that time and it was geology. Understanding a different body of knowledge, and there's a different story of a group of architects and master planners. So Michael and I found ourselves in the midst of not only developing this master plan of Wellesley, but realizing that the history of landscape architecture that we thought we knew, we actually didn't know, because there were still projects like Wellesley that hadn't had their stories told yet. It was also an interesting collaboration because when Michael asked me to be on the team, he had a different role in mind. This was a historic campus that

would have a contemporary master plan, and he wanted a designer beside himself who understood history and could translate it into spatial significance, rather than a historian who would say, “Well this is where something needs to be preserved,” or, “this is not something significant”. And so I found myself in a role of being a historian and a designer and also working with Mack Scogin and Merle Elam. It changed the way Michael practiced. He has since then had a couple of projects where historians work with him to essentially open up his way of reading sites and making sure it’s historical or cultural. So essentially this is a long way of saying that practice is something that I didn’t abandon when practicing. One thing I’m interested in is the breaking down of the barrier between history and design or theory and design.

CURRENT: So would you say that your professional life is driving your academic interests?

ELIZABETH MEYER: No, I would say that my intellectual life spans thinking and making, and that I don’t see professional and academic as separate things.

CURRENT: Professor Dodds had mentioned that you spent some time at Dumbarton Oaks as a Fellow at the same time as him. Can you elaborate on that experience and what you took from it?

ELIZABETH MEYER: Well, Dumbarton Oaks is a research facility owned by Harvard. There are three collections and three areas of expertise; one of those is landscape studies. So not landscape architecture, but landscape studies. Another is Byzantine art and the other was pre-Columbian art. The family that owned this amazing house and landscape in Georgetown gave not only their house and landscape to Harvard but also an amazing collection of artwork and books. Those three areas were this couple’s love, and so this quirky combination of Landscape, Byzantine and pre-Columbian is the connection between the three studies which comes together [in the research institute]. Each year there are maybe two, three, or four fellows in landscapes, eight to ten in Byzantine and maybe four or five more in pre-Columbian. You find yourself usually on sabbatical if you’re a fellow; the junior fellows are working on their Ph.D.; and so there’s a mix of younger and older scholars. What was quite fantastic about the year I was there along with George, was that we all had practiced at some point, whether in landscape architecture or architecture, but we were also involved in teaching or academia in some way. So I was working on this book on theories in modern landscape—George after practicing for a while and working on his Ph.D. and looking at Scarpa and his landscapes. Giorgio Galletti, who was one of the other fellows, was the architect in charge of restoring the Bobli gardens in Florence and he had become a garden historian over time. And Laura Lawson who was at Berkeley working on her Ph.D. on the history of community gardens had practiced with Walter Hood and was also shifting from practicing full time to teaching. So there was this incredible community where you would hunker down and write, but you also found yourself in these odd relationships and conversations at lunch between people that had very different interests—not only in landscapes studies but also someone that was interested in the lives of Christian Saints in the twelfth century (even though this one particular person who was a quite brilliant

scholar had grown up Jewish in New Jersey and you're thinking, "wow that's an amazing thing") and somebody else was an expert on Byzantine amulets. They were fantastic conversations. Sometimes when you're on leave, you just want to close the door and just work. But sometimes you can find yourself in a research institute where you learn amazing things about different fields. They come back and change the way you think about your own work or at least change the way you think about the periphery of your work. I know that that year I learned a lot from Giorgio, the antecedents of garden forms that derived from hunting practices, or they were part of essentially working landscapes. George's work on Scarpa was groundbreaking and the way that he shifted attention away from Scarpa's small detailed work to the dozens of landscapes that he designed. Laura took something that I just thought had come around in the past thirty years in urban community gardening and traced it back to the nineteenth century so it was a great experience. I think it is a good lesson for any academic or professional to recharge your batteries and find how you get those relationships and moments where you can do that.

CURRENT: From the abstract, it says your lecture will be discussing landscapes designed to provoke people to become more aware of how their actions can affect the environment and care enough to make changes. Do you think that the same principles of what you're discussing can be applied to other design fields, in particular the architecture field which seems more university concerned?

ELIZABETH MEYER: Oh, absolutely. In fact, the manifesto that I wrote, that's the basis for this lecture, I couldn't have written it if I wasn't in the school of architecture. A lot of the ideas are from exchanges from my colleagues in architecture and actually planning, as well. Essentially my argument is this, and I think this is also germane for architecture as well; there are not enough landscape architects in the U.S. to do anything significant when it comes to trends in global sea level rise or global warming. So all the green roofs, all of the storm water retention, all the rain gardens in the world, and I could say all the double glazed windows or bamboo from wherever, sustainable materials, is not enough. We have to understand what we do as different from restoration ecologists, or structural engineers, or environmental engineers, is that we create physical places that affect human beings. We should try to harness something that is almost a taboo word in design schools today, aesthetics; we should try to remember that space and walls and surface are not just structural issues but are intended to move someone, to affect the way they feel. Corbusier says that in *Towards a New Architecture*. It's not a manual for how to build but it's actually an amazing manifesto about the power of architecture to affect one. So we can think about aesthetics in that way, not as synonymous with beauty which is purely visual, but a way to connect our entire sensory experience, and that is connected to our brains. It means we have to realize that there's an incredible power to change the way a lot of people feel about the environment, because you might design fifty buildings in your career but how many people are going to use them, a lot more, and how do you change that group so that they change the way they think about landscape, or they might even change the way they live their every day life, and how it affects the environment in some way. In many ways, the biggest problem with sustainability discussions right now is that people assume that they can buy their way into sustain-

ability, and that form of green marketing doesn't come close to dealing with the fundamental problem which is *we need to change the way we live*. And so I'm interested in the power of design to do that not by simply being better with green technologies, but by reshaping space, reshaping thresholds between inside and outside, and re-imagining known typologies so that when somebody walks into these buildings or landscapes, it calls to question some of the things they've assumed about their relationship to the natural world. It's a big task, I know, but I think otherwise we're just putting band-aids on something that requires a lot more.

CURRENT: Along those same lines, how can we as designers prevent from designing something green just for the sake of being green? It's such a buzzword right now.

ELIZABETH MEYER: Well, one thing that's helpful is to realize that sustainability, or better off sustainable development--which was the coined term in the 80's when the UN published their report on Development and the Environment called "Our Common Future" --is not about ecological design. It is about growth that is environmentally conscious and reinforces social equity and economical health as well. So we should get away from seeing sustainability as being green, and then start to realize that sustainability is actually understanding a whole set of forces. Who's making this? Who's making money from this? Who's being harmed by this? It deals with social equity, and understanding that environmental issues are connected to economical issues, not just social justice issues. I think this will take a bit of the heat off of the green side because the equations are then more complex. What I want to add to this idea is form and beauty. The pendulum always has its swings and you're going through one right now, where an over concern for formalism can be countered for an over concern for environmentalism. I'm a big advocate of the messy middle where environmentalism is actually a social value not just a science. So, it's good to be skeptical about this, but it's also hard not to be cynical because there's so much press right now on green issues. I open up journals and it's just enough to make you say, "enough already." What you need to do is be critical and find the aspects of the agenda you can harness in a way that taps into your own values and issues, and not just something you can check off your LEED list and think it's done.

CURRENT: What role do you feel that sustainability should have in the design process? How should it respectively be integrated? At what stage?

ELIZABETH MEYER: I think that it's not something that you add, and it's not something you take as an elective. If you start out thinking of it as a value system, and tying it into technical knowledge, I think that you can integrate it in something as simple as a first year studio because you can begin to think about the simple differences in selection of site or as proficient as certain form languages and energy efficiency, without doing any calculations. If in history, you're not teaching about vernacular architecture, then you might want to do that to show the everyday common practices that make sense. So to me, sustainability is something that if you are interested in it as an ethic versus technical information, then a faculty can talk about how it spans the entire curriculum. What we did at the landscape department at UVA

over the past five years is we actually took apart our technical sequence where we used to have applied ecology classes, plant sciences classes, and then we would have these construction classes. Now every class we teach will teach something that is *ecological and technical*. When learning to build a retaining wall, you need to understand something about hydraulics from water flows through retaining walls; you need to think about the efficiency of using one material versus another relative to not just whether it's local but maybe its energy costs or who's consuming it. So we have done that with our history and theory classes as well as our technical ones.

I teach theories in modern landscapes and part of it is about how the history of science is related to design, so the students understand the long lineage of the subject. And I feel if we don't, then the environmental movement will last as long as it did in the late 60s up unto the 80s. It stayed too much of a fringe issue instead of getting under the skin of everything and everybody. So if you pull it apart and start to see sustainability as a way of looking at the world, versus technical knowledge about material fabrication or sourcing, then it's really hard to figure out where it stops in the design process. I was really taken in the special issue of JAE last fall on sustainability by an article by Kyle Moe. He's an architect I think from Cincinnati for undergrad, and I knew him when he was in the M. Arch. Program at Virginia, and he went on to do advanced work at Harvard. Kyle wrote this really wonderful article where he talked about how architecture students don't learn enough about material flows and cycles. They study a building in history or make a building in studio and it doesn't occur to them where the material came from, what its impact was on the place that it came from and clearly no idea of where that waste goes when the final product is done. So it was a neat way to analyze how we critique a building because we usually only see the fixed form, and not all the economic and material flows through the building. So there was someone who took their specialty in sustainability and took it back to his knowledge of architecture. He's a great designer, but he looked at how history classes and theory classes were needed to take on those roles. That means a really different kind of research. That means you would be working with many different fields. So, that's interesting.

CURRENT: That is interesting. Are you familiar with the 2010 Challenge?

ELIZABETH MEYER: Yes, I am.

CURRENT: We at the University of Tennessee, have just recently signed on and pledged to be a sustainable design community and carbon Neutral by 2010. I was wondering if you would comment on what objective goals, like these, not only in our situation but energy policy on the federal level or state level, can do for a subjective field like ours.

ELIZABETH MEYER: Well, like what I said before, I don't think sustainability is just metrics, although it does include them. I just think that the values you get from adopting something like this are great and I applaud you all for that. There becomes a time in your life--I'm in my fifties, and I think I'm still open to change--but I remember the time when I was most open to change and that was the time that I stopped

living with my parents and, I don't know, sometime after that. When you're in college, it's an incredibly important time where you're setting not only your professional trajectory, but you're questioning things that may have been introduced to you when you were a child, and you're starting to develop your own value system or refining that system. So, if you're in a school where things are changing based on a certain criteria, it's going to change many other things about it. Like this building, it's going to change the lighting, the heating, the food that's going to come into the cafeteria, the things were sitting on and writing on, and I think that's a powerful lesson. So it gets back to it's not only what's happening but how it's going to affect the students coming in, and how its going to call into question the environments they've been in before, the environments they're living in, whether dorms or apartments, and places they're going to make. So to me the value is that there's an example and you're an example to the rest of the school, even though it's a small global change. But every year a hundred people or so are going to graduate and do different things based on their experiences in this community, and to me that's transformative. Yeah, there are things in the classroom that effect what you do, but if you're hearing about sustainability in the classroom and you walk into a building that had a low efficiency because of its 1970's HVAC system and all the problems tied to that, you feel a little bit hypocritical, and it's nice to have something much more consistent and coherent, so for all of my poo-poo of metrics, I don't condemn them.

CURRENT: Along with those lines, as far as our school specifically, next year we are beginning a Master of Landscape Architecture program in the College of Design. I was wondering if you would elaborate on the importance of a landscape program in the college.

ELIZABETH MEYER: I think that all the problems faced in the general community can't be solved by one professional. And in fact, Groh Bruntland who was lecturing at UVA last week--she was the chair of the UN committee [on the Environment] in the 80s--was talking about the best school is one that can develop a solid group of sustainable leaders is to break down the barriers of disciplines. She said that all the tough problems need multi-disciplinary teams. So, the best thing about this program is that you will be building a broader team of collaborators and will not only see each others' work all the time, but will also have people to work with when you get out of college. And second, there are things that architects and landscape architects share as far as language and such, but there are also many different things and just seeing those differences are important. A lot of landscape architecture programs have a strong sense of reading existing sites and have an understanding of larger systems as a basis for design generation. Yet, there's a generation of architects interested in process of all kinds. I think that's kind of dominant in landscape architecture and that's a great voice to have in an architecture school where there can be such a focus on program or structure so that all the form generation can be internal. And then to realize that there are other ethical obligations that you have outside of your client that might be addressed by understanding a larger ecological and technical context of a work. That's where I think that the landscape voice is actually a very valuable one to have.

So, I think that you will find that there will be new courses offered and that's always interesting, but there are also the differences in biases and ethical positions, and it's not that one is better or worse, it's just the tensions between them are really healthy. Also at UVA, our program is 30 years old, which sounds like a long time to you but its not so long in the history of a school. But it's mostly from the students that we have become a two program department rather than two departments. Many students wanted to get a second degree because they realized they were interested in a certain kind of sustainable community and didn't feel that either profession was doing it very well. So having the two disciplines in one building in some ways sets up where the students see the pros and cons of both sides and want to try something else. I'm convinced that they will be the leaders in the next generation. So there are benefits that most faculty don't see initially. Most of the time they say, "Well, our state needs more landscape architects to fill all the positions," so they start a program, which is true. I have friends and colleagues hiring from Asia and Europe because there just aren't enough of them, but it's good it means landscape architecture is getting a lot of work. I like the fact that there are more programs because it will be a new generation of better architects as well from being exposed to other ideas of where form comes from.

CURRENT: On this final note, do you have any remarks or advice on to starting a successful program?

ELIZABETH MEYER: I was the beneficiary of one, I went back to Virginia to teach, and I had been there for undergrad. I was one of the first architecture students to decide to do the landscape architecture program, and the first thing I can say is that you have to find the absolute best people you can find. I know that Harry Porter, who was the first landscape architecture teacher at UVA who eventually became the dean, would hire people, and let people go until he got the team that he felt was really good. So from the very beginning he aspired to a program that wasn't going to be just OK, because frankly being an OK landscape architect is a horrible life. I'm sure being an OK architect is horrible, too, but this is a field that needs warriors. It needs people who are going to advocate for the environment and speak up for the others who won't do it. And so first I think you have to have the right people to be successful and find faculty who are intrigued by the broader world and their environment. And second, they need to be exciting to the undergrads, to keep your undergrads [for graduate school]; to keep some of the very best of you to stick around and create some really great alumni. And third, the field is so small that there are firms and schools all over the country excited about this program starting. I think it would be nice to team up [with other programs and universities] and create a sense of community especially when the numbers of students and faculty are small for a while.

student work -----





mary miller

a_171 professor william martella
a retreat



axonometric view

The retreat project is the culmination of a series of assignments over the first term of the architecture and interior design programs. Students begin with two-dimensional abstract compositions that address issues of visual structure, balance, form, space, hierarchy, figure/ground, and order. Through transformation, compositions are designed and evolve into three-dimensional constructs that incorporate scale and spatial sequence. Aspects of building program and response to site are integral to the retreat project.

The hypothetical site is on a flat hilltop plateau with excellent views to the south. The approach is by foot. The design proposal is for a pavilion, primarily used by one or two persons at a time. Besides the entry, two spaces are specified: an outward-focused major space and an inward-focused minor space. The design of the landscape in the immediate vicinity of the retreat extends the order of the structure into the site.

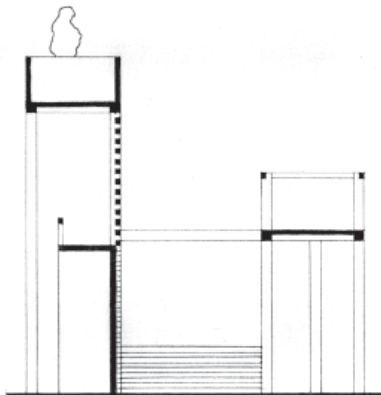

section b-b

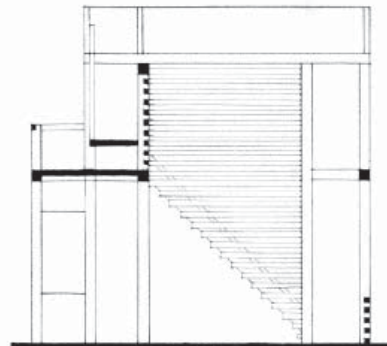

section a-a

first year studio
a_171
a retreat

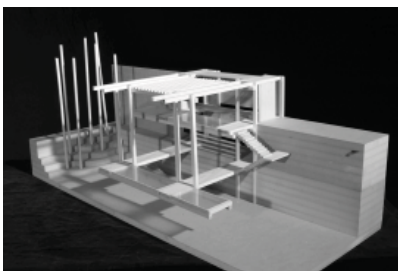

annie stone
fox studio

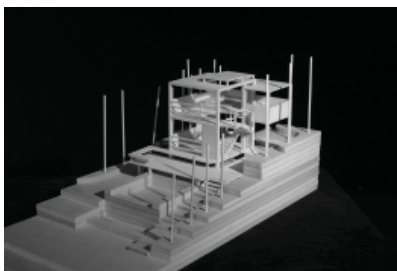

brent castro
mcrae studio

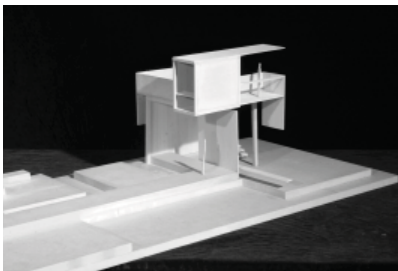

lauren bellamy
rose studio

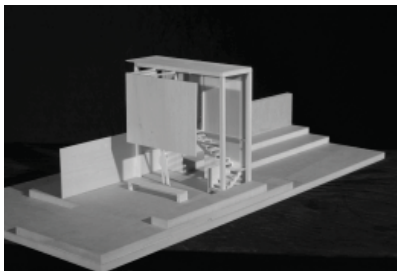

andrew martin
rose studio

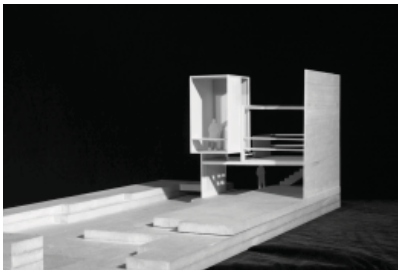

john hano
rose studio

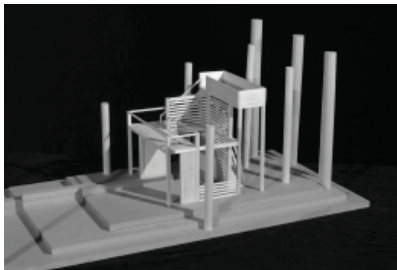

mary miller
martella studio

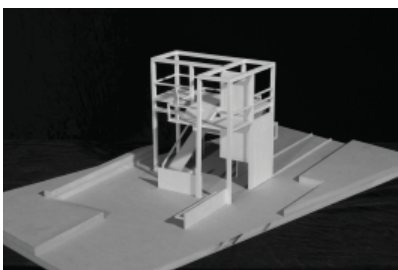

cailtin wood
martella studio

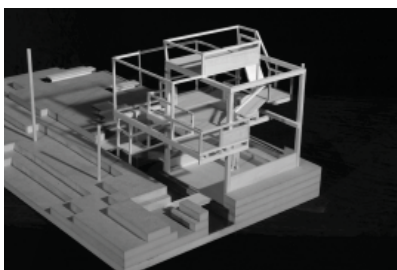

john calvert
martella studio



adam richards

a_172 professor james rose

visitor's center for the mabry-hazen house

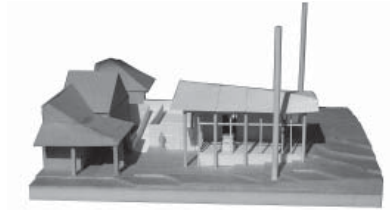
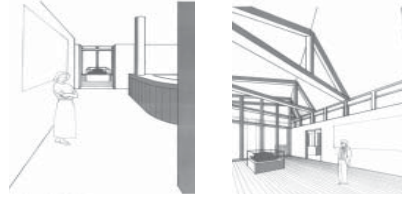

view of gallery

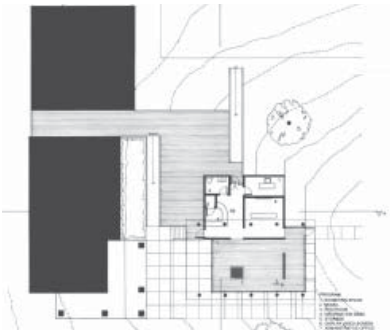

main floor plan

Situated on the highest point of downtown Knoxville, the Mabry-Hazen House commands excellent views of the city and landscape. The property contains the house as well as two smaller structures used for events and offices. The Mabry-Hazen House Foundation, which oversees the operation of the house, intends to open the building to others and is in need for a new facility to serve as a visitor center.

The project is located within walking distance from the house on property the foundation currently owns. Along with an entrance and exit sequence, accomodation to a naturally lit exhibition hall is desired.



east elevation



north elevation

carly pfahl

a_172 professor william martella
visitor center for the villa rotonda



Renaissance architects looked back hundreds of years to Roman and Greek precedents. Frank Lloyd Wright admired the architecture of Japan and Pre-Columbian America. LeCorbusier studied industrial buildings as well as the design of ships, automobiles, and airplanes, and one can see forms and ideas from these precedents in his architecture.



view of entrance

As a follow up to a precedent analysis, students were asked to design a visitor center for the Villa Rotonda based on some of the ideas, principles, and ordering devices they previously studied. Assuming that the foundation looking after the Villa Rotonda is planning to open it to visitors. The final product is a 1400 square foot facility. It includes a model space, restrooms, information desk, storage, display kiosk, bench seating and an administrative office. The building also serves as the main circulation entrance to the Villa.



view of entrance from north

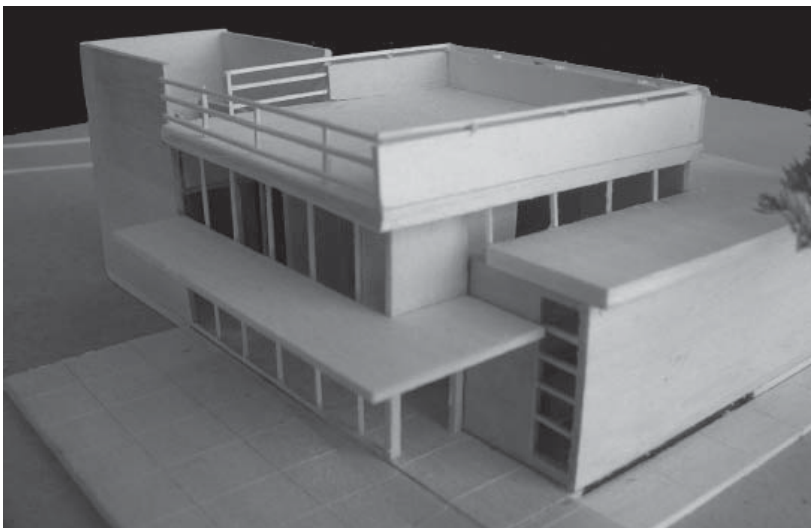

view of viewing platform facing the Villa Rotonda



andrew pittman

a_271 professor jennifer ackerman
old city ceramics studio



floor plan

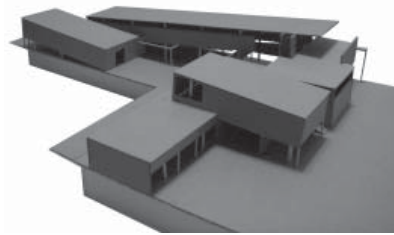

model photograph

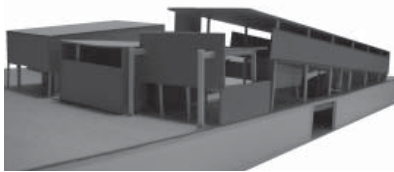

model photograph

As a practice, ceramics is sometimes considered art and sometimes considered, dismissively, as craft. If an object is functional, is it no longer art? Are architectural ideas on the relationship between form and function related to this question? Ceramics are often the oldest archaeological traces left of civilizations. Are there ways to architecturally reference how ancient and significant this practice is? What are the possibilities related to thinking about clay? To thinking about the process of creating ceramics?

This project is a Ceramics Studio + Gallery located in the Old City neighborhood of downtown Knoxville. The structure will serve as a teaching institute offering beginner, intermediate, and advanced classes in hand built and wheel-thrown ceramics. In addition to regular ceramics classes, the Studio will offer weekend or week-long courses in special topics, bringing regional artists to the area. The building will house a series of gallery spaces intended to exhibit a range of shows. These will include shows for student work, university student work, and the work of invited artists. As well, the Gallery will be open to the City of Knoxville



view of entrance



This is the first project of the 271 design sequence. Issues include the introduction of design in the urban context, the bearing wall structure, and the shaping of space through section. Students also dealt with issues of repetitive systems reacting and changing due to site constraints and orientation.

The site is an infill lot located at the north end of the 200 block of Gay street. The program is comprised of six individual units with a bearing wall structure and both public and private exterior spaces which support a public and/or commercial program at the street level. Students were given less program than what is needed to fill the site to force them to deal with the negative space or "void" created by their intervention. This project explores the idea that space aligns with structure, in contrast to the second design project in 271 where structure, enclosure, and space can separate with the use of a column and frame system.

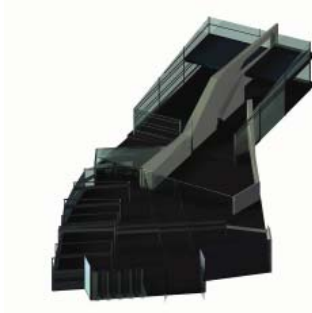

massing diagram

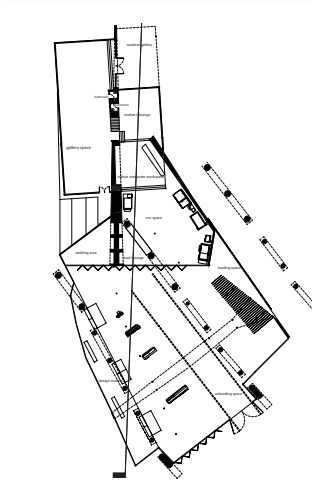

first floor plan



section 01



rear elevation



fleming smith

a_272 professor katherine ambroziak
hoo center for theater and film

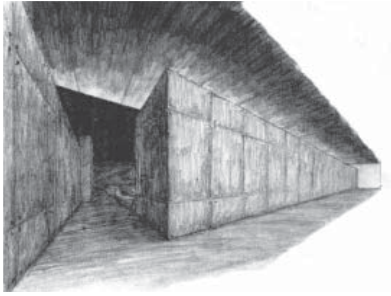

view of theater entry

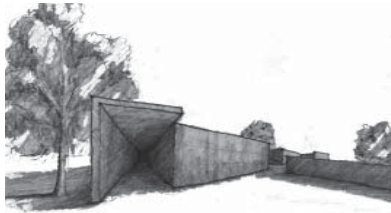

view of theater entry

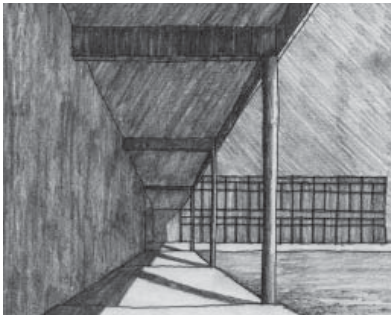

view by academic wing

Each October, the Virginia Film Festival takes the stage at the University of Virginia. The Festival attracts national recognition for its unique mix of entertainment and education. Each year the Festival explores a particular theme which illuminates the social and artistic impact of movie-making. Directors, actors, scholars, and writers further enrich the Festival experience through panel discussions and special events. Reflecting Charlottesville's literary climate, the Festival gives special attention to the perspectives of noted screenwriters, novelists, and critics.

The premise of Hoos in the Dell is that the Department of Drama has been endowed to build a new School of Film on the grounds of the University of Virginia. The school is meant to serve annual visitors to the Virginia Film Festival as well as provide a center for research and teaching. Based on the success of the Politian Theatre at the Dell and the increased involvement of students through the Virginia Players, the University decided to use the outdoor pavilion as the cornerstone of the new school. Through the incorporation of the Politian Theatre into the Hoo Center for Theatre and Film, students drew upon previously established site design strategies, integrating the public sequence and highlighting the conceptual basis of the original design.



plan 01

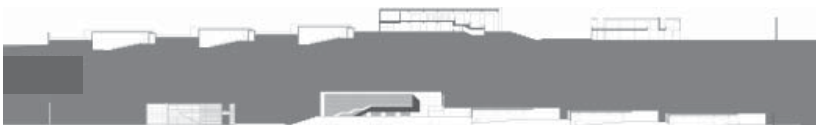

building sections

andy ruff
a_272 professor katherine ambroziak
hoo center for theatre and film

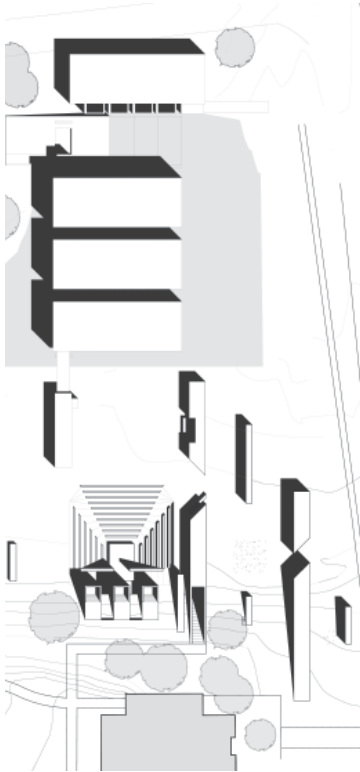

view of theaters



view of theaters



site plan

view of theater entrance

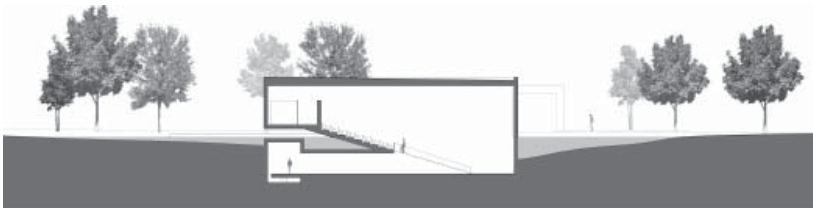

section through theater

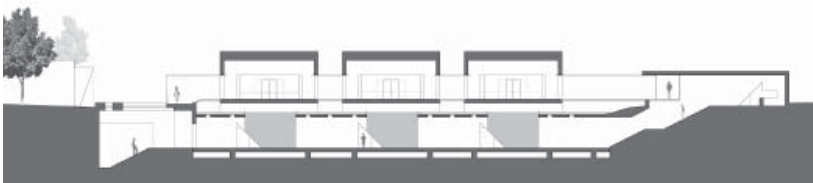

section through
hoo center



josh johnson - jimmy ryan - caitlin turski
a_272 professor brian ambroziak
lanternpod

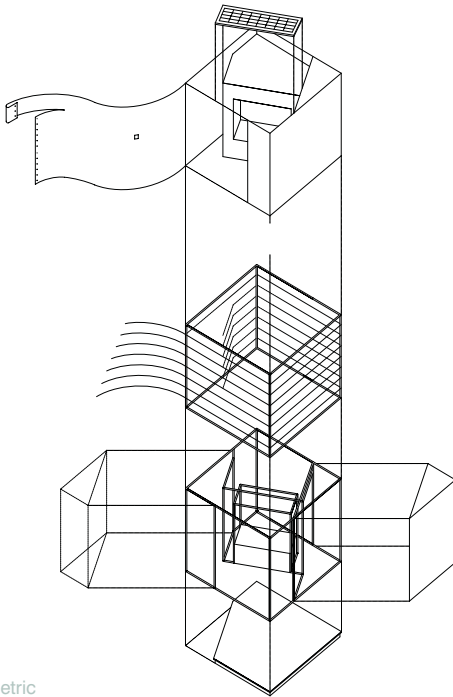

exploded axonometric



exploration of transparency

As a starting point of this project, students were given excerpts from Jorge Luis Borges's *Library of Babel* and Italo Calvino's *If on a winter's night a traveler*. While Borges's text transforms the library into a powerful and visually compelling fiction that exists as 'an indefinite and perhaps infinite' universe, the opening of Calvino's work embraces the everyday by addressing the art and nature of reading. This project challenges students to create an idealized reality within which one may become lost completely in a realm of fiction.

The project asks students to design a prototypical cell for study and meditation. In this investigation, students are to consider a variety of scales that range from that of the campus to the keyhole. Each student began by constructing a full scale mock-up of their cell using 1" PVC pipe and fittings. They then positioned their framework on various sites around the College of Architecture and Design, occupied the space as they would if they were studying, and then looked (listen, feel), observed, and discovered. Their constructed framework was considered a vehicle for translating the unique qualities of place into three-dimensional space. As they sat in their newly constructed machine, they were to consider the effect site has, over multiple durations, on all the senses and imagine how one might use material, sound, color, texture and form to generate spatial moments that both heighten and dull the senses as deemed appropriate.

analysis of movement



view of pod at night



jimmy ryan

a_272 professor brian ambroziak
dr. seymour i. schwartz map library



The designer of the 21st century, more often than not, plays the role of Icarus perched some thirty-thousand feet in the air. Taken for granted, an aerial image, that happens to be geo-referenced, provides a puzzle that is first and foremost a set of geometries, lines, and forms that detach themselves from the scale and the speeds of an urban text and provide an image devoid of human experience.

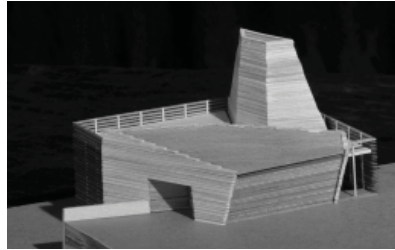

model

For the past century, society has been consumed by scientific pursuits, by the acts of classifying and calculating. Ultimately, as we have collected more and more information, we have found ourselves in a world as Baudrillard commented with, "less and less meaning."

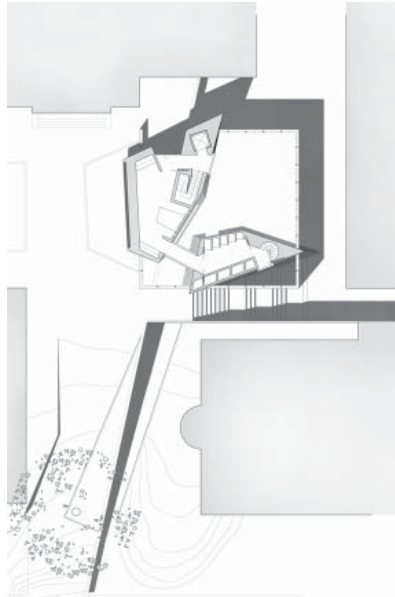

first floor plan

It can be argued that our modern tapestries have evolved into a form that do not represent the rituals of the diverse cultures they capture, they have lost the spirit or soul possessed by the work of early cartographers.

In this project, students were expected to travel back through time and examine man's attempt to reduce wonder to a scale more susceptible of human cognition. Ultimately, like the generations of cartographers before us, students generate visual arguments positioned somewhere between fiction and reality, they tell stories that reveal something about who we are as a culture that serve to elevate the human spirit.

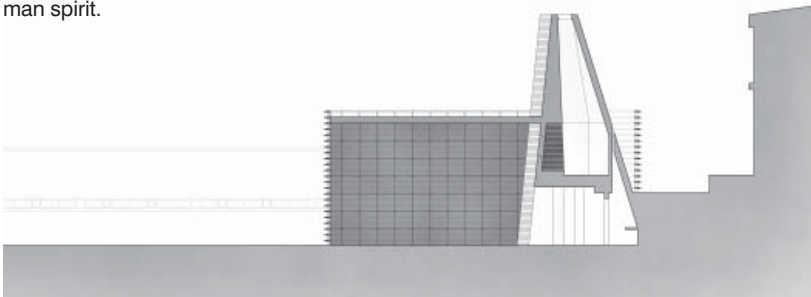

section through
map library



paul legan

a_371 professor max robinson
electronic multi-media juke box

This project was based upon the premise that the University sought to replace the existing University Center and that it would be accomplished through a two-stage process that first created a structure containing a series of spaces for meeting and ceremonial assembly before the original building was supplanted with one accommodating the service facilities that it originally housed. The projected building's facilities included a large, flexible multi-purpose assembly hall, major and minor auditoria, a series of smaller, multi-purpose meeting rooms, a foyer, lobbies and gallery for circulation and exhibition, as well as, the requisite administrative and service facilities required by the functions and activities planned to be conducted here.

An additional parameter was added as a foremost consideration in the development of the project's solutions. The place's relationship to the remainder of the University should also be proclaimed, both physically and symbolically, as the architecture of the

ceremonial center can furnish a special imagery that enhances the events staged to occur there. The imagery resulting from the formal aspects of the center's solution should express the qualities of ceremonial center and raise the proposal to the status of architecture.

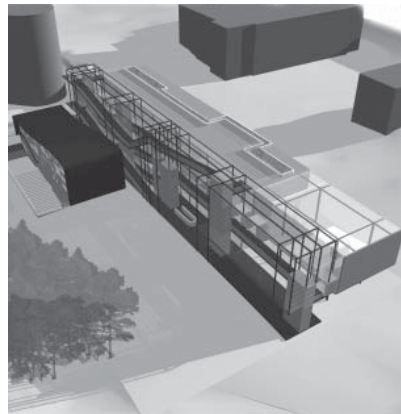

view from northeast



view of major
assembly space

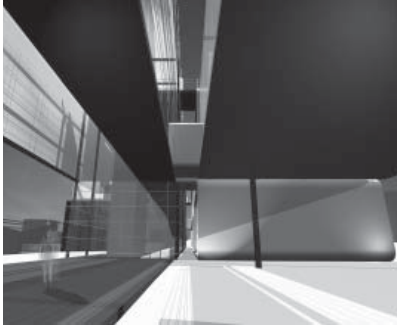

view of gathering space

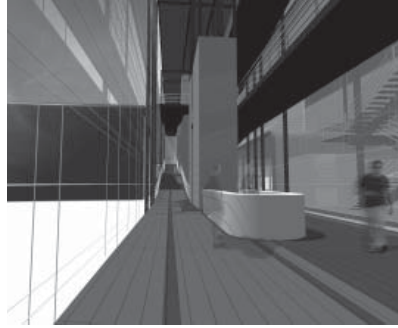

view of entry lobby

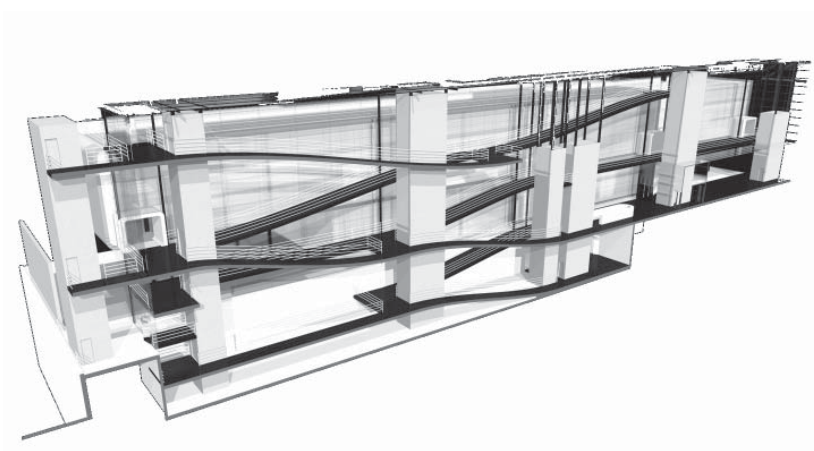

section through
circulation tower

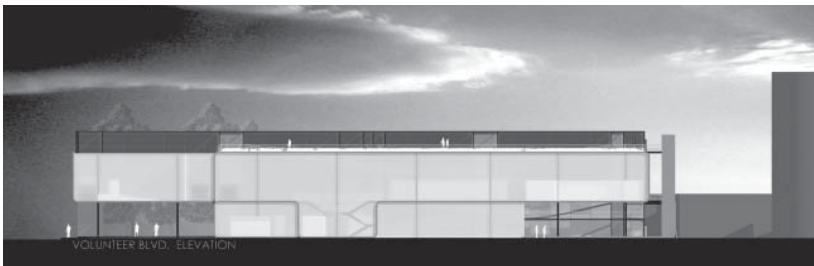

west (uc) elevation

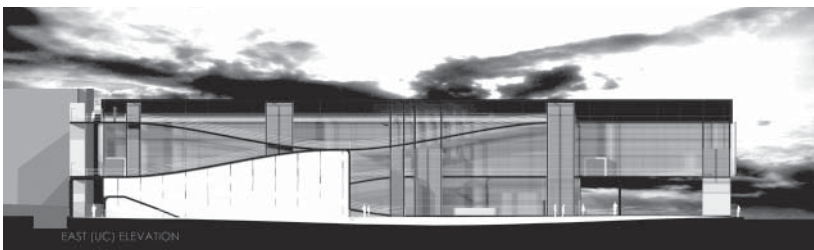

east (uc) elevation



chris green

a_371 professor max robinson
electronic multi-media juke box

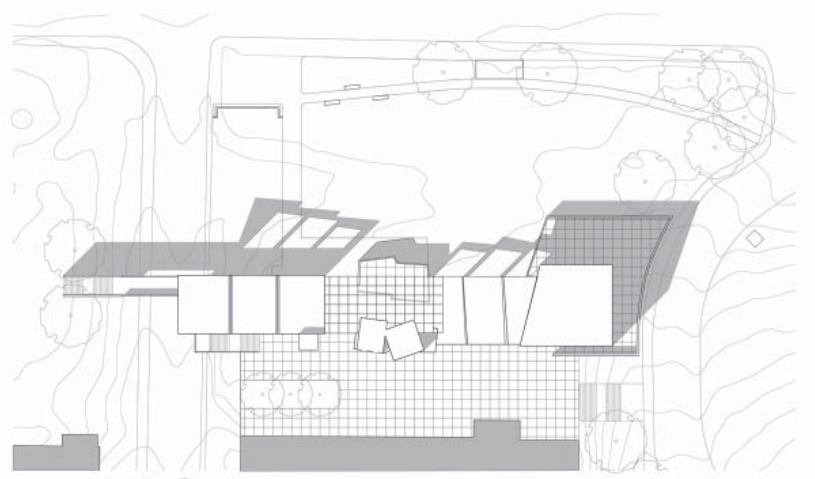

site plan

This project was based upon the proposition that the University seeks to amplify the production and presence of its research, proposing to do so through the direct physical showcasing of its results and products. This entailed designing a multi-media exhibition pavilion strategically located on the campus between the Walters Life Sciences Building and Cumberland Avenue. It was conceived as an electronically controlled machine with the capability and flexibility for presenting information in an indeterminate variety of fashions, from the actual experiential staging of materials to their virtual representation in varied visual, kinesthetic, and auditory formats.

One of the primary considerations of this project is that the results of research emanating from the diverse disciplines encompassed by a university are of such varied nature that they are not all capable of being displayed in a typical museum or gallery setting. Consequently, the manners of staging the works within the facility will need careful consideration of the issues of flexibility and architectural coherency.



section through pavilion

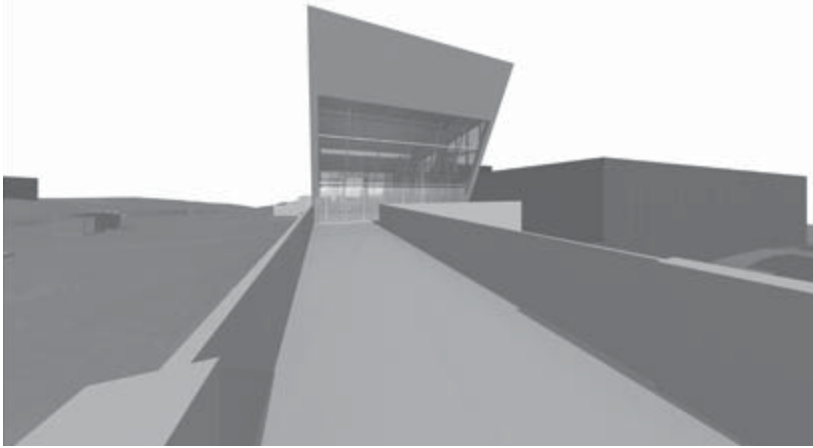

view of entry

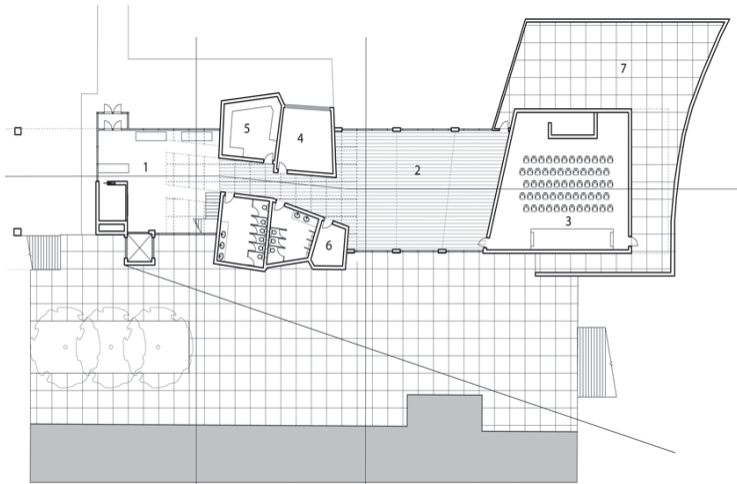

plan 01

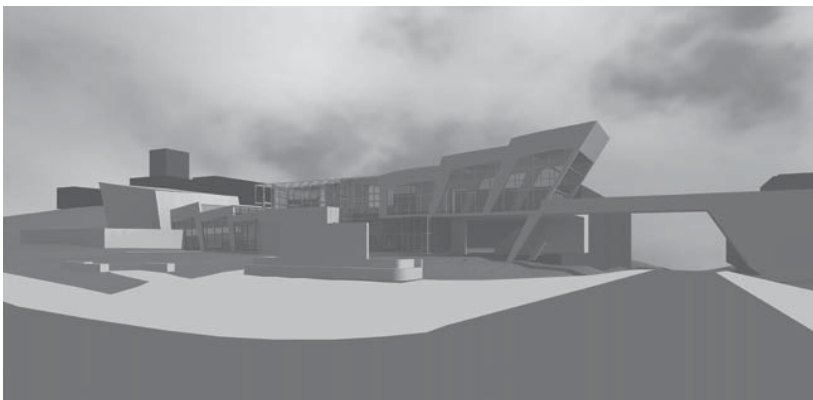

view from
cumberland aveune



brent hunter

a_371 professor tracy moir-mcclean
high density urban ecosystem

This project calls for the design of a mixed-use development on a sparsely vegetated site adjacent to a regionally significant creek and associated riparian habitat in Portland, Oregon. The design encourages environmentally sustainable development practices and ecological restoration, as well as functioning as a highly desirable model for future development within the Metro area. The design of the development improves habitat connectivity through the restoration of existing habitat and introduction of new habitat corridors, applies resourceful, creative stormwater management practices, provides for the housing, commercial and recreational needs of a diverse community, and develops clear linkages to a light rail transit stop and a major recreational corridor/bike trail.

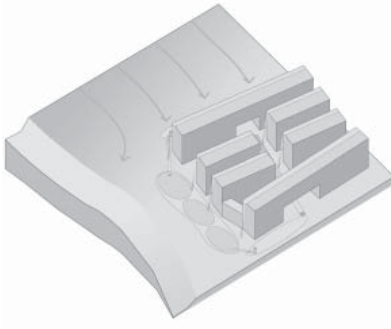

site axon and water collection



exploded axon of unit types and circulation systems

view from ramps overlooking courtyard

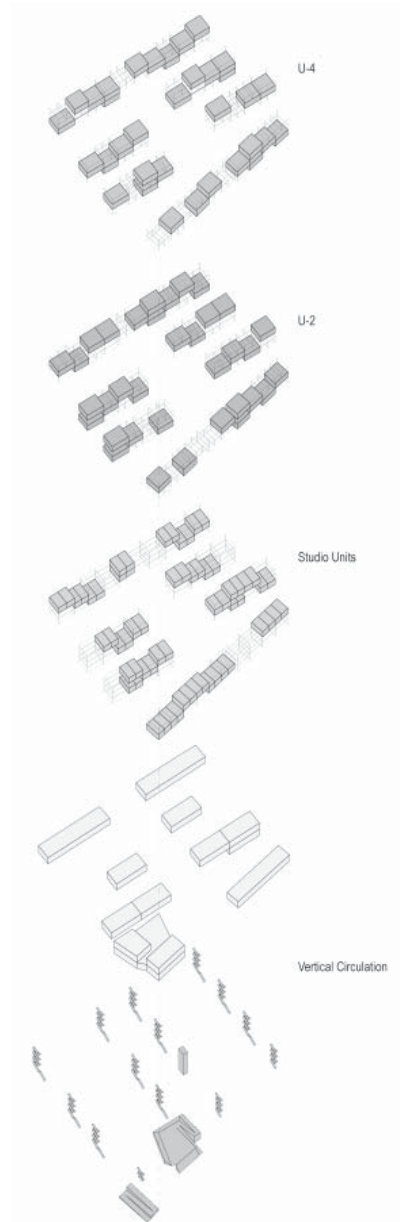

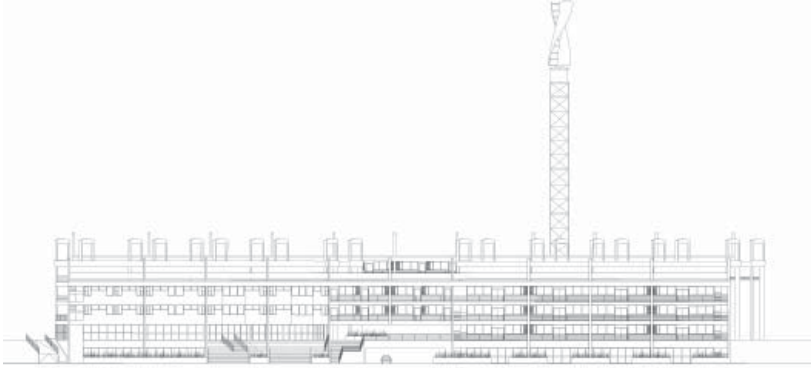

elevation



section



view from community center bridge overlooking constructed wetland



samuel mortimer

a_372 professor william martella
concrete_thinking for a sustainable world

This design solution stems from thoughts on reinterpreting and establishing ideas of a sustainable lifestyle in a blighted area of Knoxville by restoring production and the process of creation. The presented solution attempts to address that connection by establishing the center as more than just a facility to sort recyclable materials – but as a community center equipped to tackle issues of sustainability on a larger scale than simply the built environment.

Critical to site choice is the close proximity of several key urban elements. Residential areas lie within walking distance and the Second Creek Greenway, which parallels Second Creek, is vital to making this connection. Proposed within the design solution are secondary routes to create a physical connection between the outlying residential zones and to the site of the recycling center.

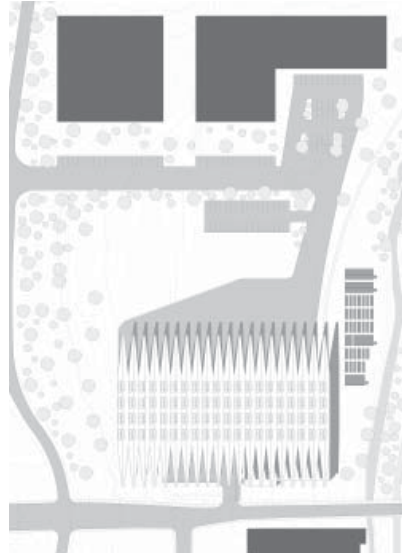

site plan

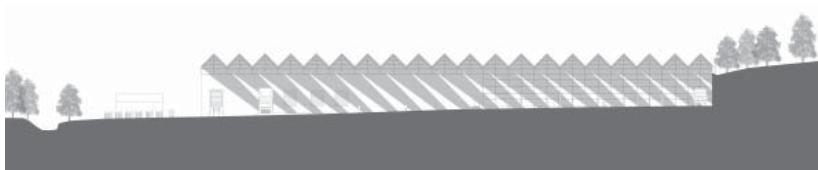

north elevation revealing second creek and working yard

a sustainable farming initiative was added to the centers program. urban agriculture offers innovative and economically viable opportunities for the local community. programmatic elements include demonstration plots, greenhouses, community beds, as well as a composting operation.

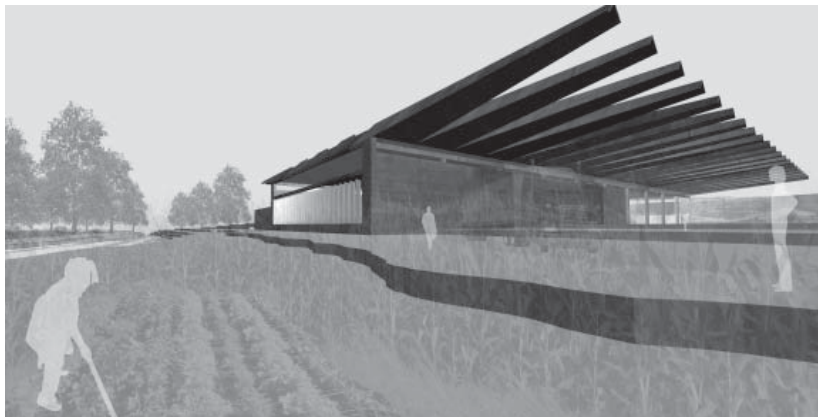



longitudinal section revealing long span structural requirements

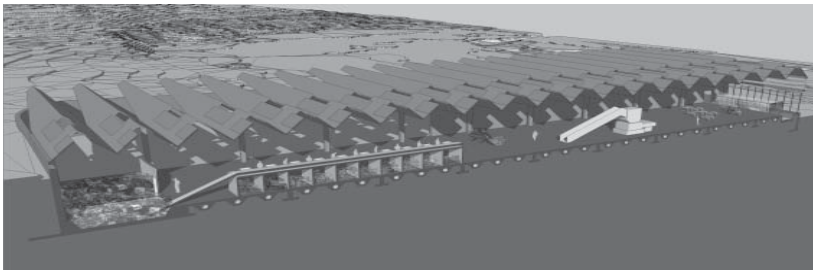
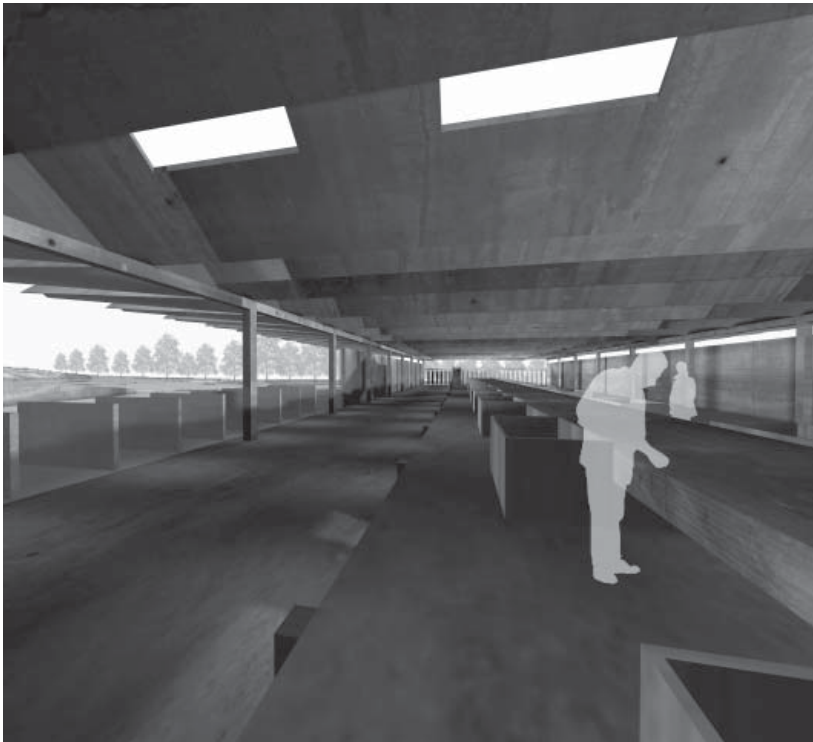

diagram of recycling process



interior of center looking down the longitudinal axis of the sorting line. operable glazed facade to the north allows views to the working yard beyond.



levi hooten

a_372 professor french
apartment and studio for a photographer

The proposed solution attacks a narrow urban site that measures 25 feet by 67 feet and is aligned with two adjacent structures: an auto shop to the west and a taller post office to the east. An alley to the north sits twelve feet lower than the front street on the south end. The program of an apartment for a photographer called for three distinct components: residential, work-space, and gallery space.

The concept that was defined sought a relationship between the photographer and the city that exist at two different scales. As well, it allows the city and its residents to understand internal spaces differently as the function of the unit changes from work-space to display. The hierarchical piece of the program, the office of the photographer, is understood both as an internal space and an external perspective. While the spaces and volumetric readings of the unit give the concept foundation, the façade sets the concept in motion. With a construction of glass and a combination of different operable systems, the façade adapts to function. Much like the photographer frames with geometric intention, the façade frames views from and to the city.



view down the main stair

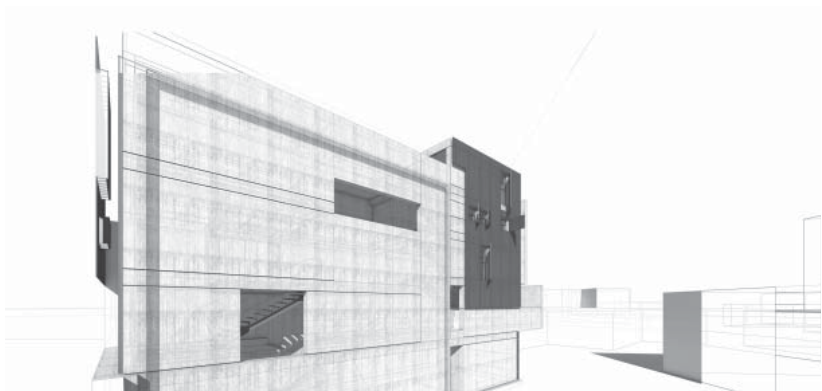

view of party wall
connection

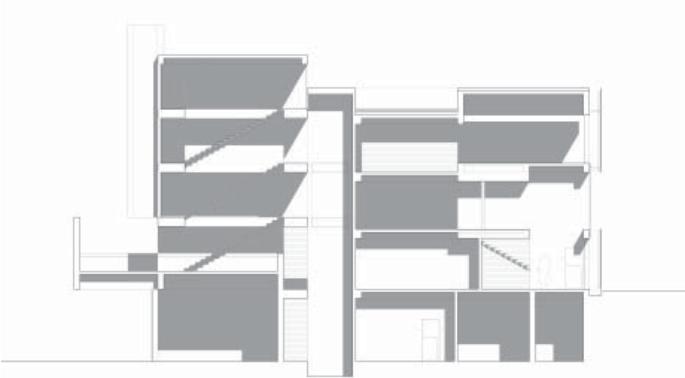

longitudinal section

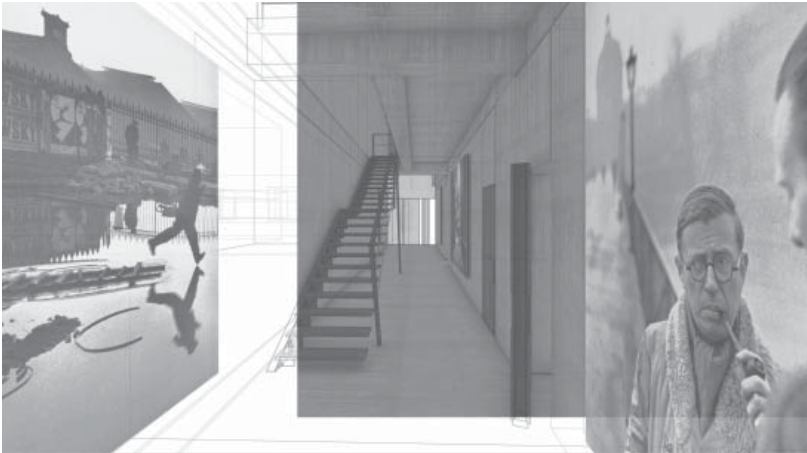

view of gallery

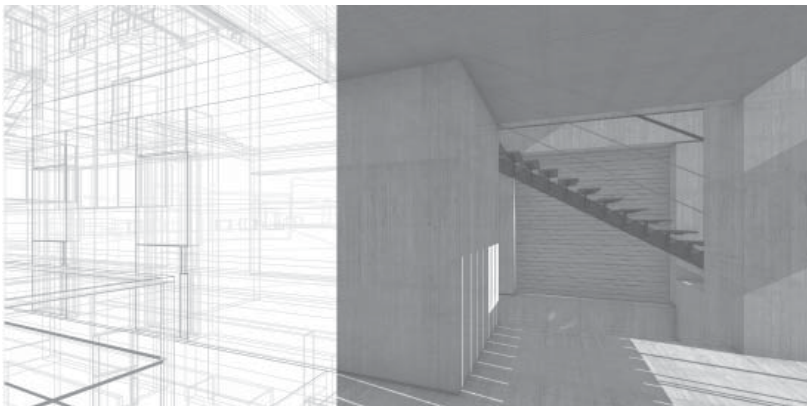

view of gallery



polly horne

a_471 professor ted shelton

the long tomorrow, aia middle tennessee design award - honorable mention

This project imagines that the University of Tennessee has established the Long Tomorrow Institute which is charged with bringing internationally recognized leaders from a range of disciplines to the university for the purpose of addressing intractable global problems with very long time frames. In order to support the Long Tomorrow Institute, the University will establish a new campus center to compliment the historic center of the hill. Bounded by Andy Holt Avenue, Melrose Place, Melrose Avenue, and Francis Street, this new center will seek to unify the western portion of the University campus while largely retaining its traditionally residential scale and use.

The University will build additional scholars' housing and a new 1,000 seat lecture hall. Understanding that its buildings and landscapes project its values, the University seeks to build in the most progressive manner possible; understanding and mitigating both the immediate and long-term impacts of the project – particularly those that contribute to resource and habitat depletion and global climate change.

It is the intent of the University to create a sort of campus within a campus on this site that establishes a comfortable setting for the work of the Institute and fosters formal and informal interaction between the Long Tomorrow scholars during their resi-

site plan

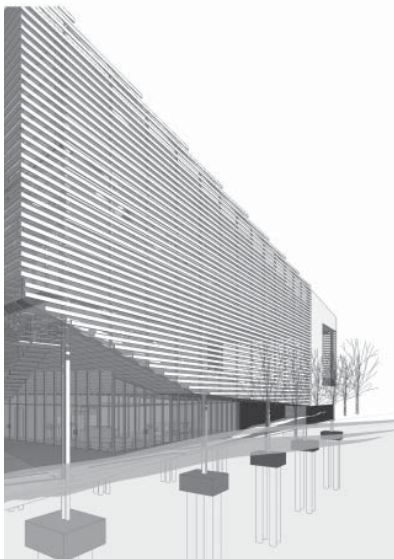
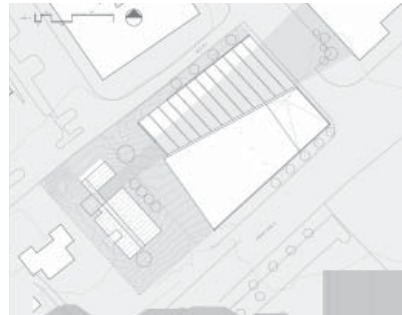

floor plan 02

view towards entrance





ashley bigham

a_471 professor ted shelton
the long tomorrow

I find some of my new works disturbing, just as I find nature as a whole disturbing. The landscape is often perceived as pastoral, pretty, beautiful... But anybody who works the land knows it's not like that. Nature can be harsh – difficult and brutal, as well as beautiful. You couldn't walk five minutes from here without coming across something that is dead or decaying.

Andy Goldsworthy

The inspiration for this project came from the artist Andy Goldsworthy. A sculptor, photographer, and environmentalist, his work with the decaying state of natural objects was the driving force behind this design. The juxtaposition of harsh and fragile beauty is used to create a dynamic

composition. This juxtaposition was expressed by a thin outer container holding the heavy auditorium within. The rotation of the auditorium that relates to the pedestrian walkway and the scholar's community begins to puncture the fragile container. As one piece shifts, so does the other. The shifts work together to create special moments within the space. A curtain wall system of operable wood panels was designed to meet the shading and daylight control needs of such a large space. The operable panel system maximizes the potential for natural daylighting and radiant heating as well communicating visually with pedestrians.

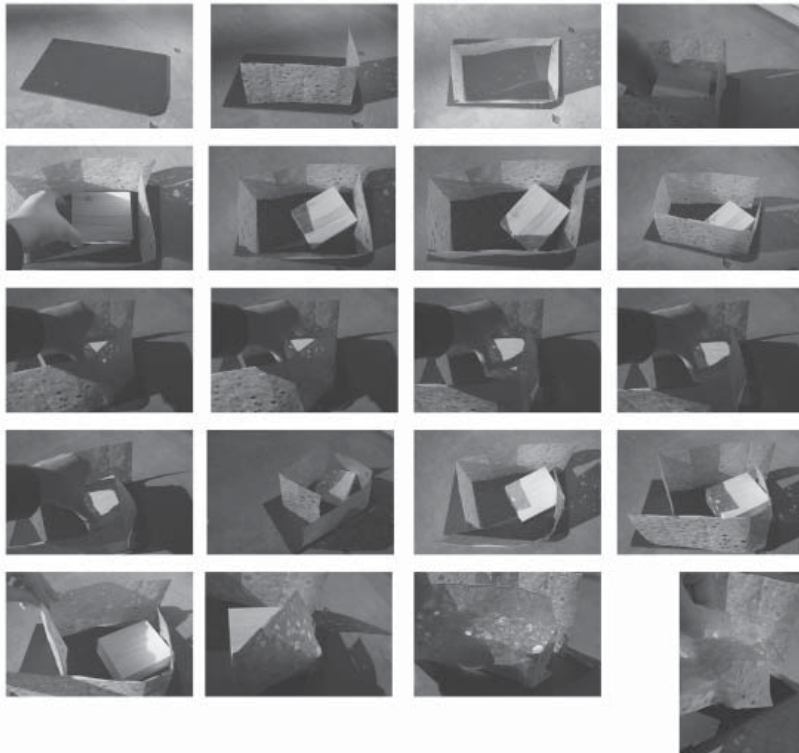

photographs showing subtle rotation of the solid auditorium piece and its influence on the fragile skin of the facade system.

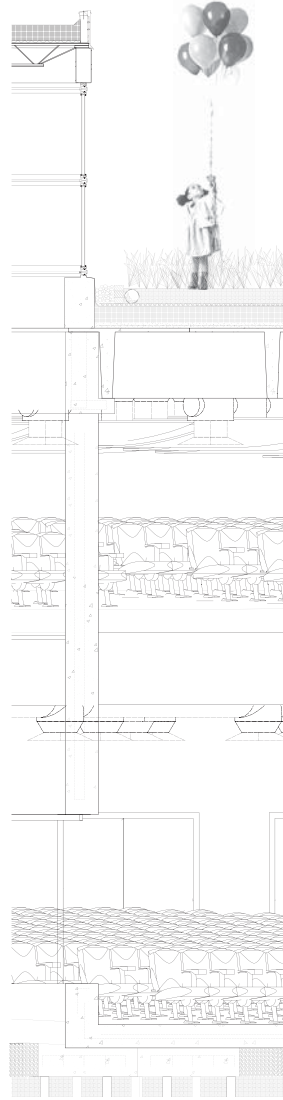
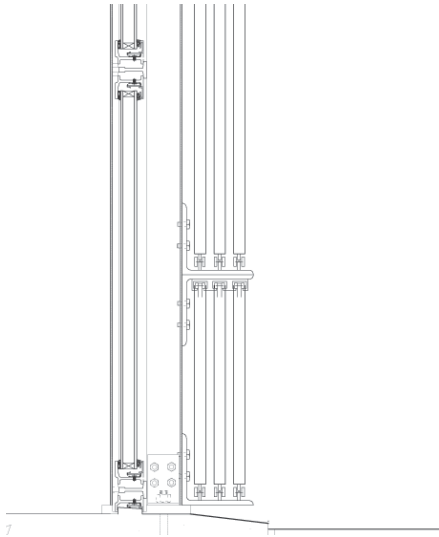

street facade wall section

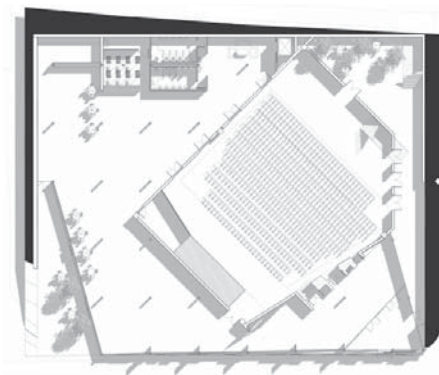

plan 01



lecture hall wall section

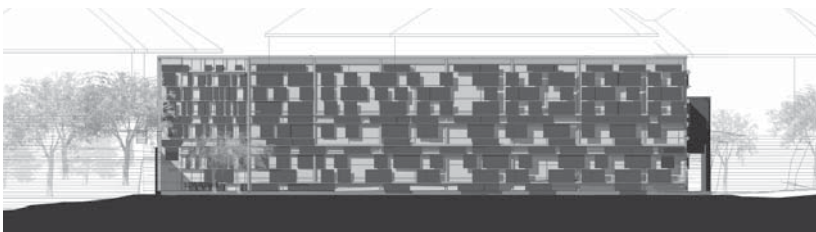

south elevation



curtis jennings

a_471 professor james rose

se corporate headquarters, *aia middle tennessee design award winner*

2nd avenue elevation

1st avenue elevation



broadway elevation

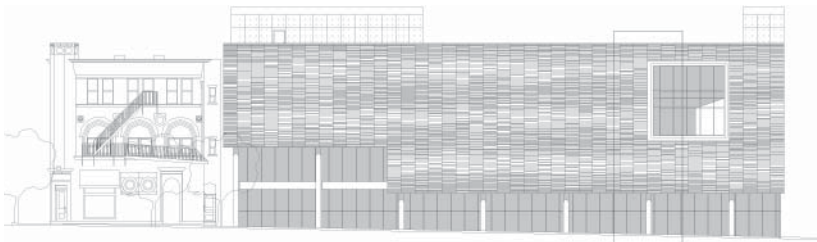

Convergence. The site for this design is located in downtown Nashville, Tennessee. The site is surrounded on three sides by streets and to the north by a party wall. There is a historical building that occupies the southwest corner of the site. Upon entering the site from Second Avenue the visitor will enter a plaza where they must make a few choices. A person going to the retail area located on the ground floor, with which they have a direct visual connection, is able to look down onto the space from the plaza off of Second Avenue. The visitor going to work is pulled back towards the north wall by the sound of water flowing in a hidden stream along the north party wall. The stairwell at the nodal point, where the building is the closest to the party wall, is cut back at the angle parallel to the party wall to emphasize the entrance to a space within the city. This space is oriented to give views of the river, riverfront, concert stage, bridge, and sculpture across the river.

The building design focuses towards leed goals, specifically day lighting and views. The design of the façade is floor to ceiling glass to optimize the amount of sunlight that can penetrate within the building envelope. The large window area is covered by a screen which consists of fluorescent tubes held in a structure of a three inch by three inch aluminum i beam, spaced vertically at two inch, four inch, and six inch increments. The fluorescent tubes are protected from the elements by a single pane of glass attached to the vertical aluminum columns by spider clips with a standard aluminum storefront design on the interior to protect them from breaking on both sides. This screen will act as a subconscious billboard to the city and occupants of the building to reduce the use of electricity during hours when indoor lights are not required.

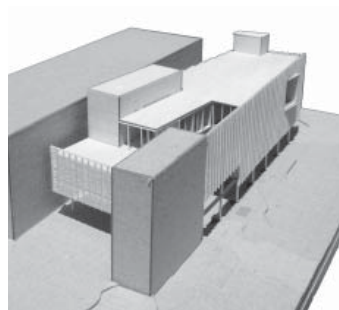
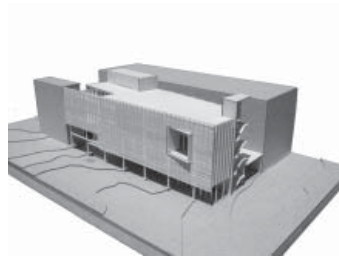
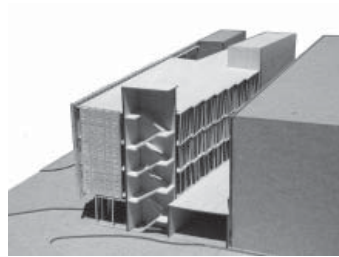
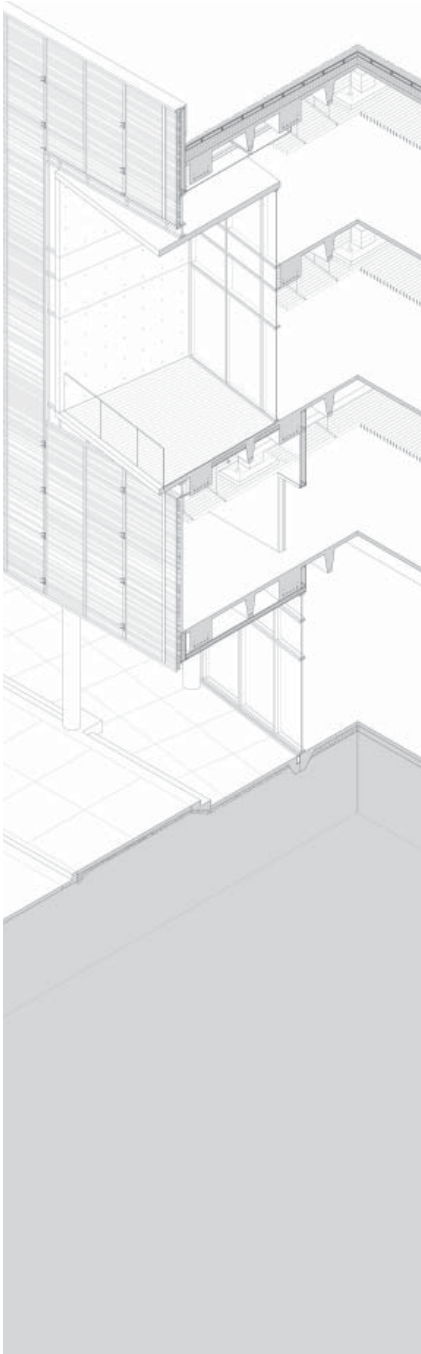

detail wall section

model photographs



emma perry

a_471 professor robert french
se corporate headquarters

Progress, Shift, Pause, Discover. Sited along Nashville's growing riverfront, the design for the new SE Corporation Headquarters embraces the water's edge while maintaining its place in the downtown district. The building is designed to welcome, capture, and radiate the essence of downtown Nashville.

Visiting the new SE Corporation building, one progresses through the spaces established by the shift of experience from Second Avenue to First Avenue, allowing one to pause and rediscover the newly defined riverfront.

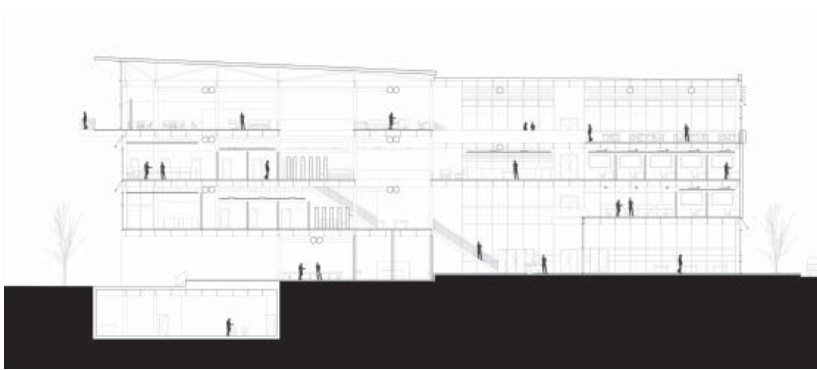

longitudinal section



view of courtyard

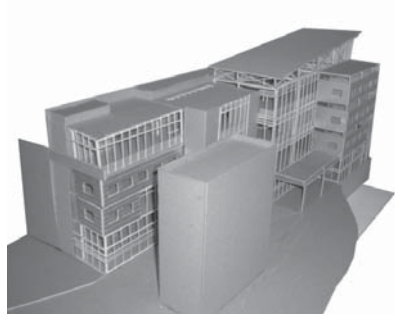

view down
second avenue

model photograph

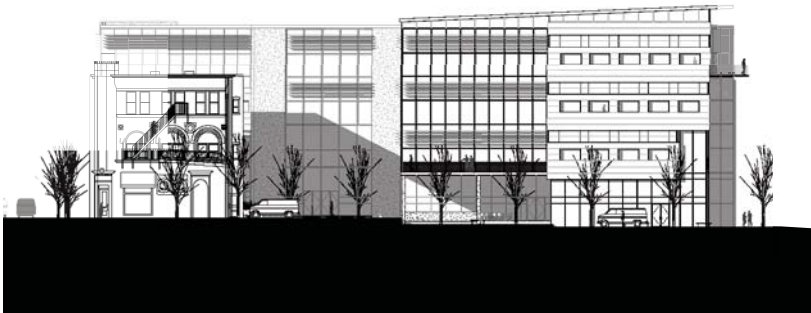

main elevation



view from
first avenue



alan michael - melissa frame

a_472 + id_472 professor paul mccall - margaret denney
sunrise crossing



site plan
view from street



Sunrise Crossing is a mixed use development in downtown Knoxville. Bounded by Union Avenue to the south and Locust and Walnut Streets to the west and east, the site utilizes an existing brick-built storefront building, traditionally known as the Daylight Building, and an existing adjacent parking lot.

The development consists of renovations to the existing building as office space with ground floor retail and a mixed-use structure on the remainder of the site. Within the new structure are Independent Living Apartments, situated on the west end of the building, a Boutique Hotel making up the eastern half of the building, a shared lobby, restaurant, and various public meeting spaces. Drawing from existing conditions of the Daylight Building, the new structure completes Union Avenue's unique character by extending a cable-suspended awning along the South facade, creating an intimate, pedestrian-friendly space above

the streetscape. The awning continues as a vertical element, creating a support structure for balconies connected to the apartment units, while also acting as sun shading in the evening.

Certain elements of the general program, namely the lobby, restaurant, wellness center, and typical boutique hotel room are further developed through a presentation of interior space planning, swatches, color schemes, and numerous LEED certified materials.

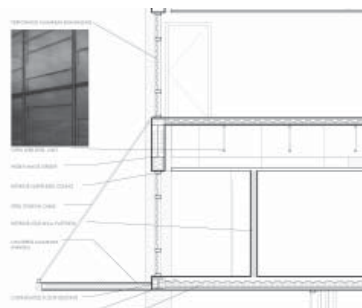

detailed section



north elevation



lobby and restaurant plan

apartment and hotel plan

view of entrance



view of hotel lobby

view of hotel room

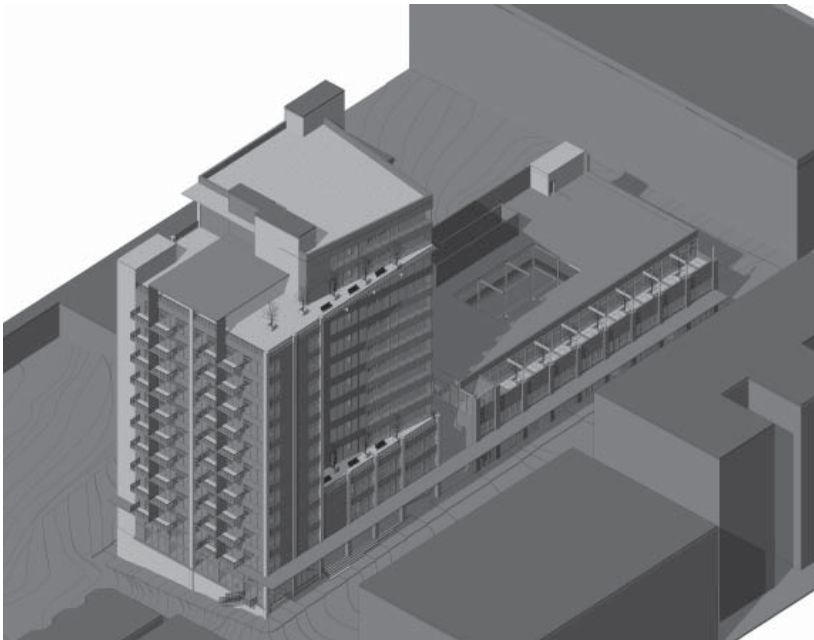

axonometric view



rachael stollar

a_481 professor brian ambroziak
monastery and mission

This project situates a monastery and retreat house in spatial composition with a mission on the Los Angeles river, a massive concrete barrier that provides at best a place for the homeless to illegally wash their clothes. While the monastery represents a closed system, the mission projects an image of openness to the community and helps those most in need. The mission fulfills a physical service while the monastery exists for spiritual service. This project asked the student to consider the blurring of these discrete boundaries.

This design references and represents in spatial terms the *via crucis*, a path of pilgrimage that represents Christ's path to his ultimate crucifixion. This spiritual path is divided among the monastery and the mission and becomes recognizable without being literal.

view through orchard
walking towards
the monastery

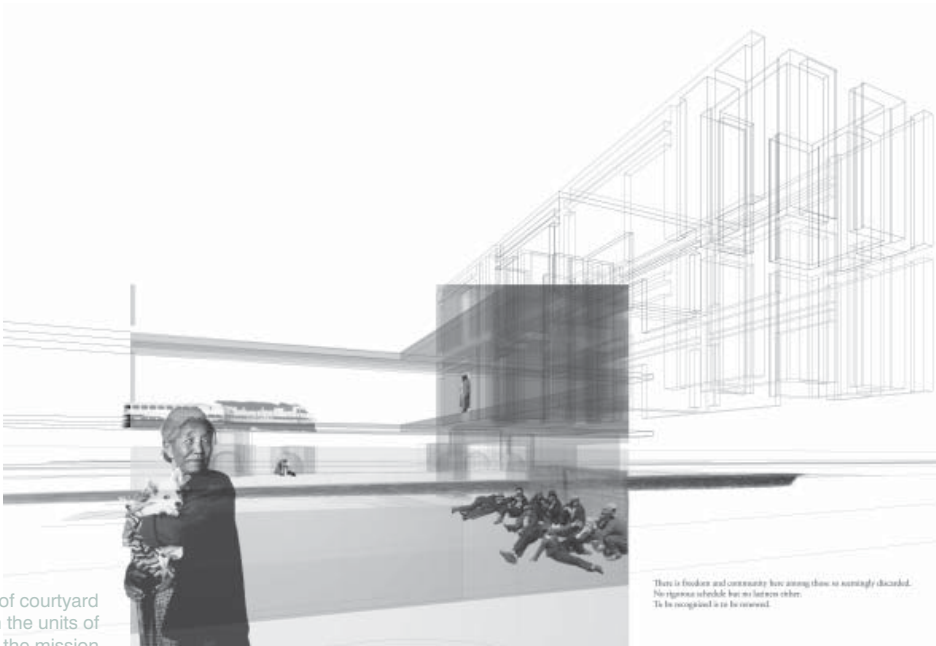

view of courtyard
between the units of
housing for the mission

There is freedom and community here among those so seemingly discarded.
No rigidity of order, but no laissez faire either.
To be recognized is to be renewed.

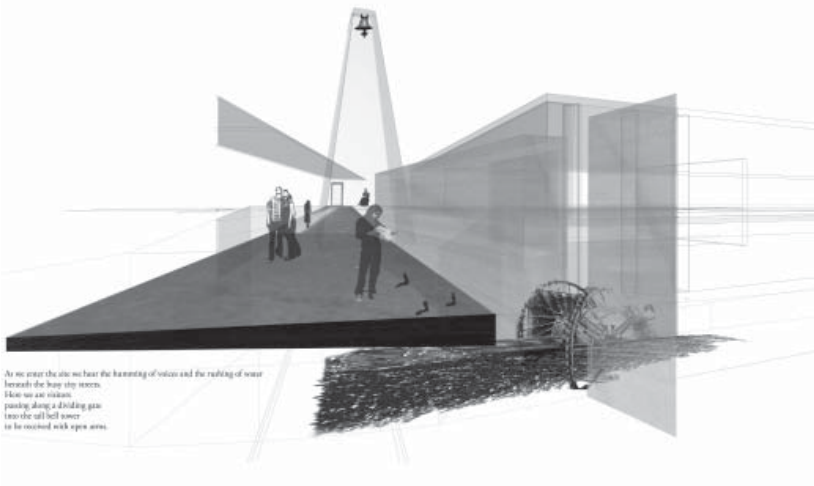

As we enter the site we hear the humming of voices and the ruffling of water
beyond the busy city streets.
Here we see visitors
passing along a dividing gate
into the still pool water
to be received with open arms.

view across the path to
the entrance of the site
passing over the water
wheel connected to the
mission

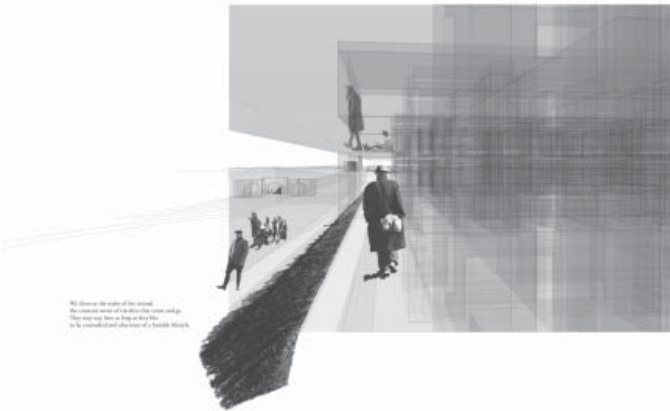

We observe the water of the canal
The water wheel of the site
The water wheel of the site
The water wheel of the site
to be received and observed of a humble monk.

view along the path that
connects the mission's
housing units.
in the distance are the
chapels where the
tenants can meet
with a priest.

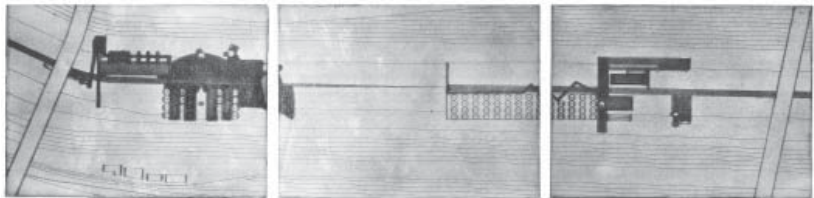

site plan
(intaglio print, black ink
on watercolor paper)

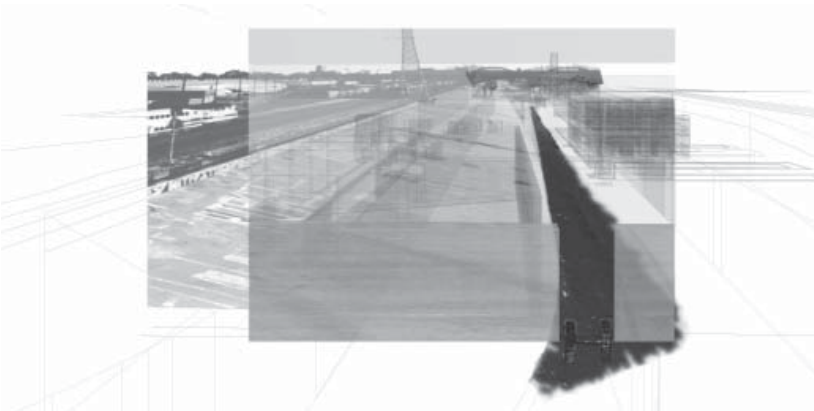

view over the site from
the point of entry on the
bridge overpass.



joseph watson
 a_481 professor brian ambroziak
 monastery and mission

A monastery and a mission within the Los Angeles river basin uses ideas drawn from Soren Kierkegaard's theology to define paths through the site taken by a monk, a homeless person, and a pedestrian. Each has a unique experience of the site that stretches for almost half a mile on the edge of the city. Light, color, water, sound and material provide a restrained palette against which a multitude of visual, tactile and auditory experiences occur.

In this project, a suspended pedestrian bridge spans between seven chapel towers rising from the monastic gardens. The mission at the midpoint of the path and the monastery at the end become clear thresholds for the different visitors to the site. At these gateways, depending on whether or not one is intended to continue beyond a certain point, one's experience becomes more visual or more tactile.



aerial perspective
 illustrating arrangement
 of mission and
 monastery along via
 crucis within highly
 symbolic landscape

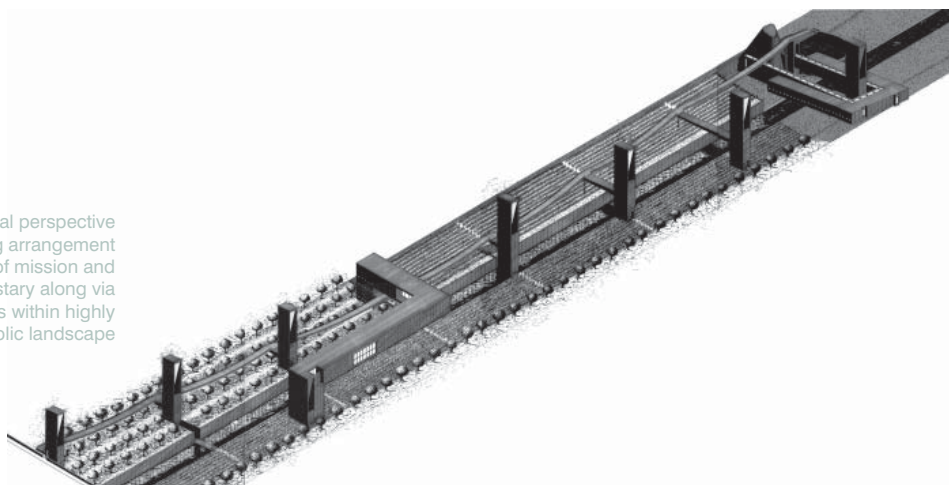



longitudinal elevation

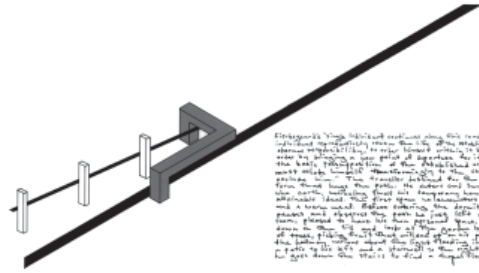

Stjepanović's long, horizontal roofline along the road suggests a low, almost flat, structure. The building's facade is characterized by a series of vertical elements, possibly columns or supports, that create a rhythmic pattern. The drawing shows a cross-section of the building, highlighting the internal structure and the way the roof is supported. The text to the right of the drawing provides a detailed description of the building's design and construction, mentioning the use of concrete and the specific structural elements used to support the roof.

mission

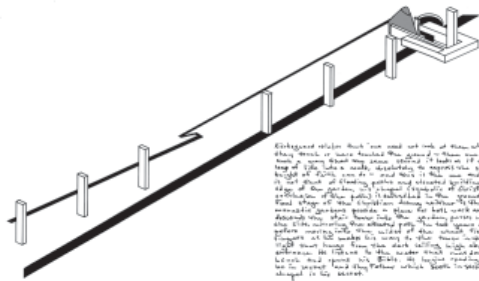

Stjepanović's long, horizontal roofline along the road suggests a low, almost flat, structure. The building's facade is characterized by a series of vertical elements, possibly columns or supports, that create a rhythmic pattern. The drawing shows a cross-section of the building, highlighting the internal structure and the way the roof is supported. The text to the right of the drawing provides a detailed description of the building's design and construction, mentioning the use of concrete and the specific structural elements used to support the roof.

monastic

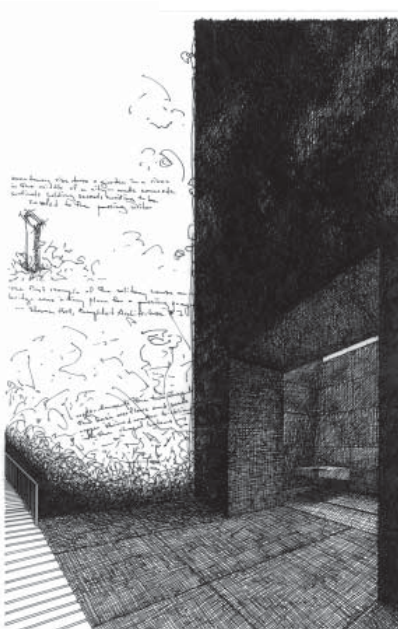

Handwritten notes and sketches on the left side of the rendering, including a small drawing of a person and some text.

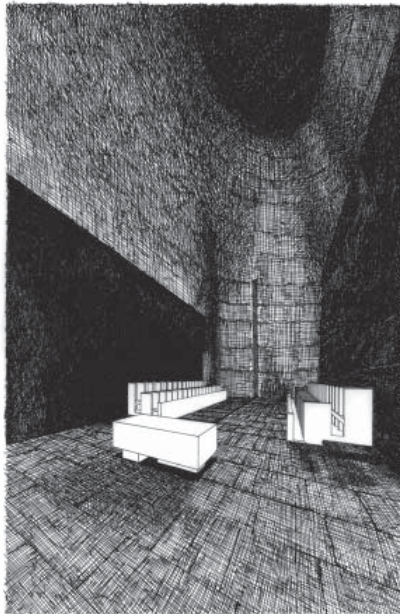

rendering of chapel tower

rendering of monastic chapel interior



diana morelock
 a_481 scott kinzey
 south knoxville riverfront housing

Empty Nester home: This design objective was to design a single family home on a steep site over looking the Little Tennessee River and the downtown Knoxville area. The edge conditions become very important between building and exterior space. Large glass doors can be opened up to create a blurred sense of enclosure. this way the expansive garden space can be enjoyed throughout the home.



Young Professional: A goal for both houses was to try and preserve and respect the beauty of the site. The steep slope of this lot began to dictate the demographic. Each floor steps down with a change in function. This change in floor level serves as a connector of building to site and user to site. The residents will be continually reminded of the severity of the slope beneath them.

site plan of empty nester house

This group has relatively different needs that that of an empty nester. Assuming the residents would be quite social and require space for entertaining, the floors are zoned according to function. The main floor is accessed by a bridge on level with the road. This floor is used for entertainment - living, kitchen, and dining. An vop-

erable glass wall opens up to allow the deck to become part of the action. Much of the facade has a level of transparency for more public functions. The bedrooms are quiet and much more private. When one is in their bedroom it will be up to them to be part of the activities happening else where in the house.

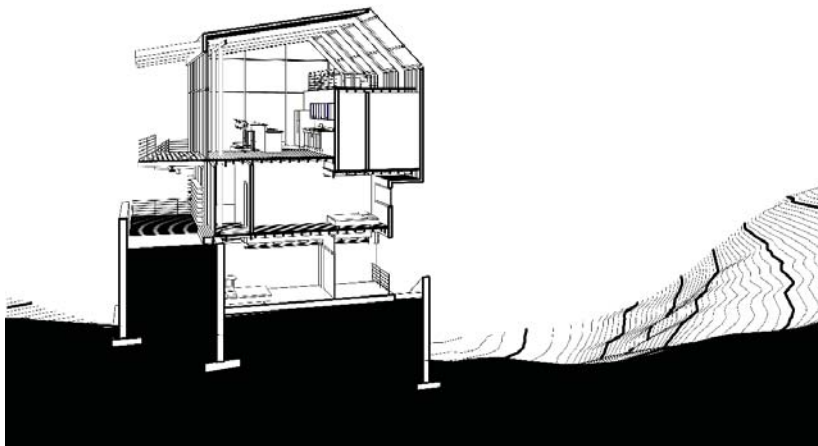

sectional perspective through young professional house

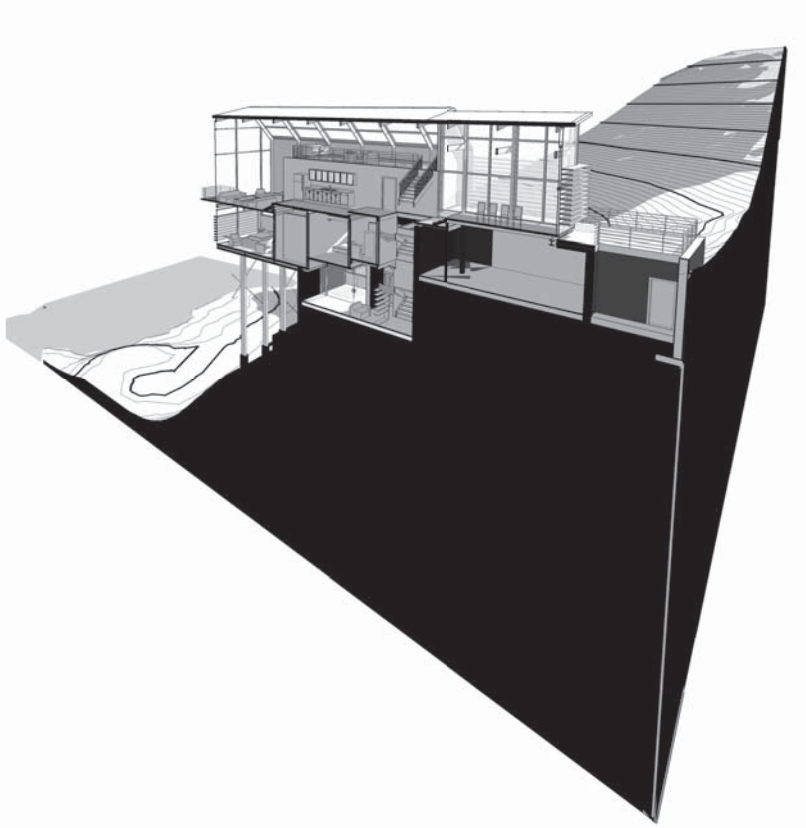

sectional perspective
through young
professional house

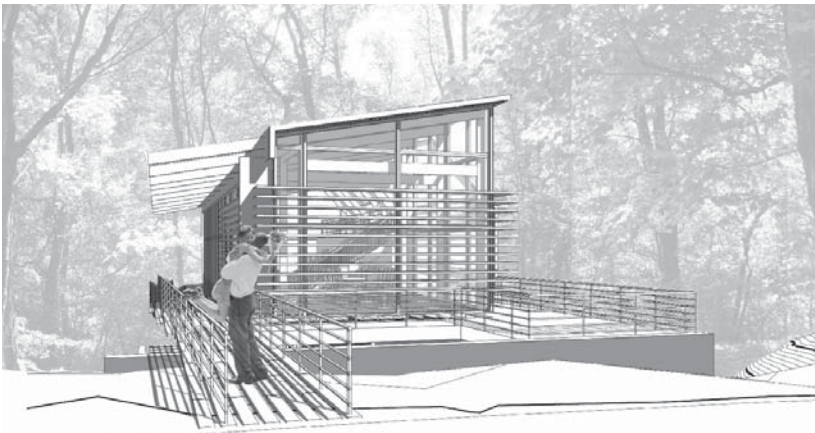
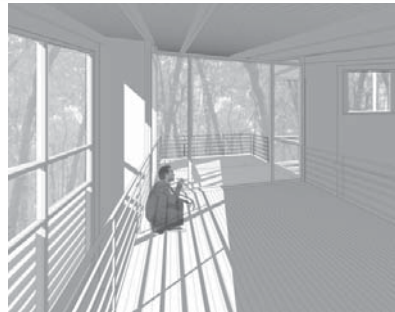
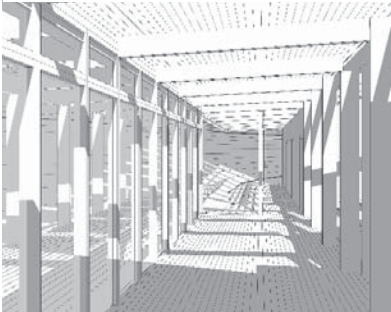

view of main entry of
young professional house



meghan mccrary

a_481 professor tricia stuth
re:place

This studio investigated the re-development of an existing neighborhood as a [p]refabricated community. Specifically, it examined the technical, social, regulatory, and aesthetic issues associated with the pre-fabrication of urban in-fill housing in south haven, an existing post-war neighborhood in Knoxville.

Most suburban dwellers have huge back yards that are wasted space. This solution creates shared yards and focuses on the relationship of the tower and garden as well as public and private relationships of those that lived there. The yard has three components: a garden, a yard, and a shade garden. A community house in the yard provides work spaces as well as outdoor gathering areas for the neighborhood.

The tower is seven stories tall with four apartments. Every other level, there are “boxes” that contain shared program for both the users of the building and the house directly adjacent.

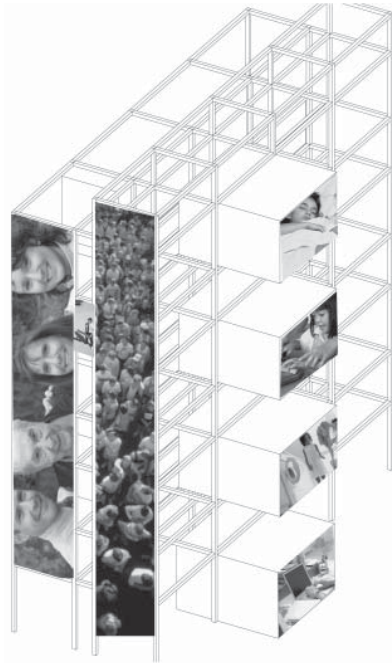

zones are separated to create filters from the very public outdoors to the quiet indoors



site plan

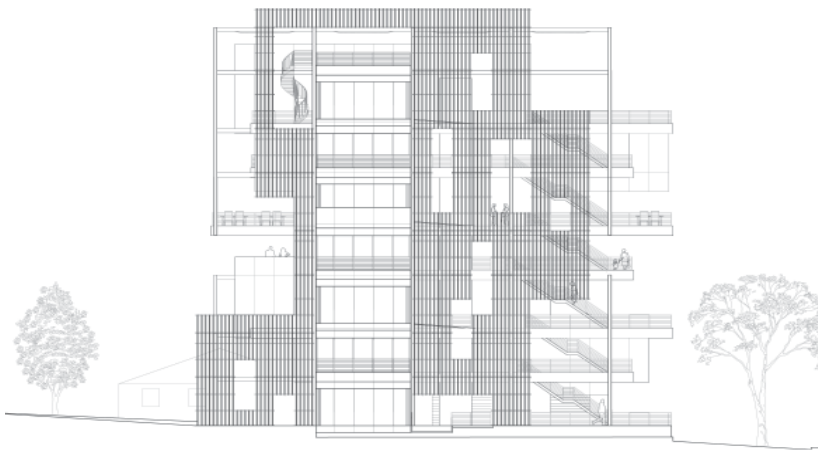

the east wall is transparent with wood louvres creating the walls that indicate its public space inside. the boxes are made of glass and are completely transparent to the activity inside. at night, these towers light the neighborhood sparsely in comparison to the dark post war houses next door.

east elevation



michael davis

a_481 professor tricia stuth
re:place

Using the post-war house's origins (efficiency and economy) as a starting point, this project looks towards the next 50 years of a typical post-war neighborhood. The phase-based nature of the project allows for a natural growth to occur on the underutilized site and provides opportunities for connections and overlaps between blocks as the neighborhood evolves.

Building upon the idea of an evolutionary neighborhood, the approach to the housing units within the block provides variety, mobility, and adaptation by design for REASSEMBLY. There are two new housing types introduced: the DUAL DENSITY unit and the STITCH unit. The DUAL DENSITY unit uses a steel frame to adapt the existing house on a lot to modern living and provides the structure for a new house to be built on the lot, occupying the "airspace" of the existing home and augmenting its relationship to the yard. The house is constructed of a prefabricated kit of parts consisting of a steel frame and screw pile foundation, floor and wall panels, an exterior wooden "skin", and a corrugated metal roof. This kit of parts is designed for assembly through bolt connections and uses permanent fasteners to a minimum to allow for DISASSEMBLY of the unit. This disassembly is necessary for the subsequent REASSEMBLY of the kit of parts to construct the second house type: the STITCH unit. The Stitch unit is a reaction to the realization that the original houses will one day be gone. This type allows for a vertical arrangement of spaces to reduce the footprint of the house. It also provides for a denser arrangement of units that recalls the typical rowhouse typology.

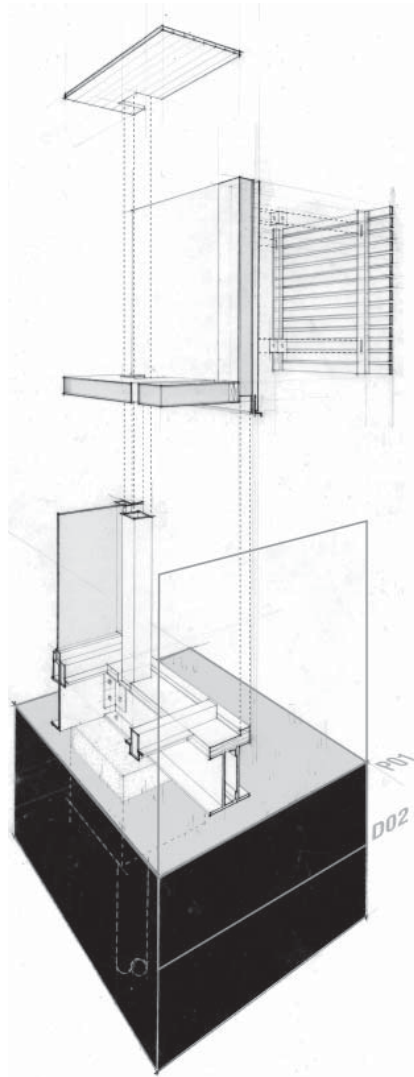

wall assembly
axonometric

elevation



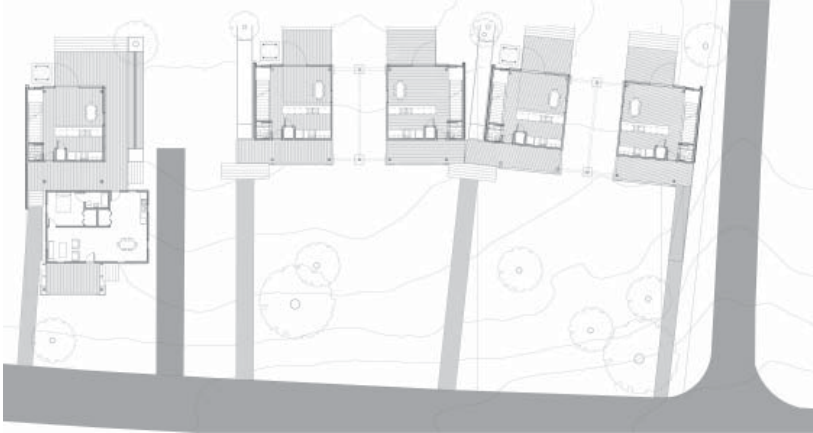

site plan



perspective of
stitch units



sectional perspective
of stitch unit



mikey kenney

a_481 professor tricia stuth
re:place

People used to gather around the fire for warmth and story-time. The town well was a place for people to come and get their water and exchange stories. Not only did these elements serve a functional purpose, but they allowed for the interaction between people. With technological innovations, the need for people to come together has disappeared. Suburban sprawl has decentralized the urban fabric. There is a need for reconnecting people in the suburban context. It is within the housing for the middle class that the greatest opportunity for urban revitalization lies.

By creating a series of nodes that function on different scales and levels there is the hope of reconnecting people through a transition of public to private zones. "Community Nodes" are the source of power, parking, and social functions that will service a smaller group of people within the neighborhoods.



view of entrance
from courtyard



view of exterior facade
from courtyard



"The public and private spheres should develop a close relationship without losing their polarization. The more closely the polarization is oriented and the closer the interchange between public and private spheres, the more urban the life."
 - Aldo Rossi, Architecture of the City

site plan



view of dining room
 looking out to balcony



view of bedroom on
 lower level

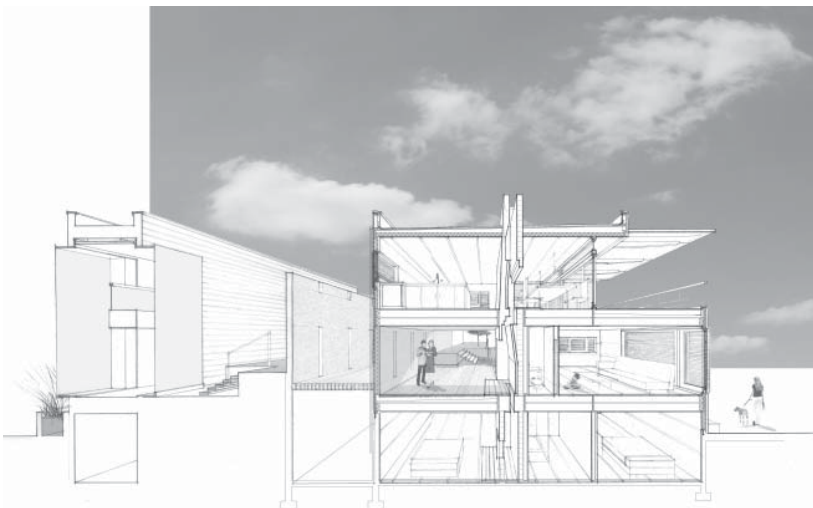

longitudinal section
 through unit



dianna morelock

a_482 professor scott wall

inhabiting the phenomenal landscape, *tau sigma delta bronze medal winner*

It is in our best to interact with the land in a way that will educate others on the need to maintain a balance between human activity and nature (building & site). The intent was to explore the possibility to describe a narrative of a site through the way in which it is inhabited. The historic relevance of a place can guide the appropriate programmatic use of the site for present day and into the future.

Fontana, North Carolina once provided a path for the little Tennessee River to flow between its mountainous terrain. In 1942 TVA made the decision to flood the river valley in order to produce hydroelectric power. This begins to describe something about the way each culture understands and interprets the landscape. How does our generation's use of the land begin to reflect what we see as important? The hillside will house a research facility for twenty visiting professionals with a ties to the study of the interaction of human activity and the use of land.

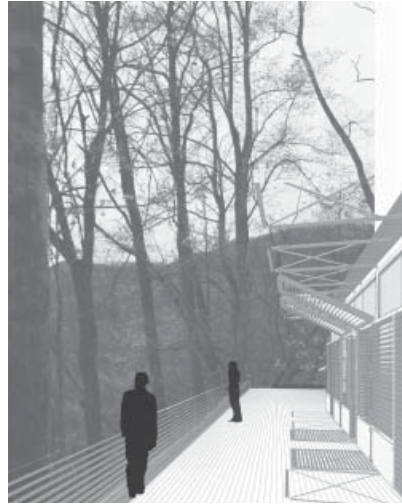

They will have the opportunity to acquire a vast knowledge of the history of the site and use it to conduct their own studies of the land use at Fontana.

view toward river from camper's sleeping deck

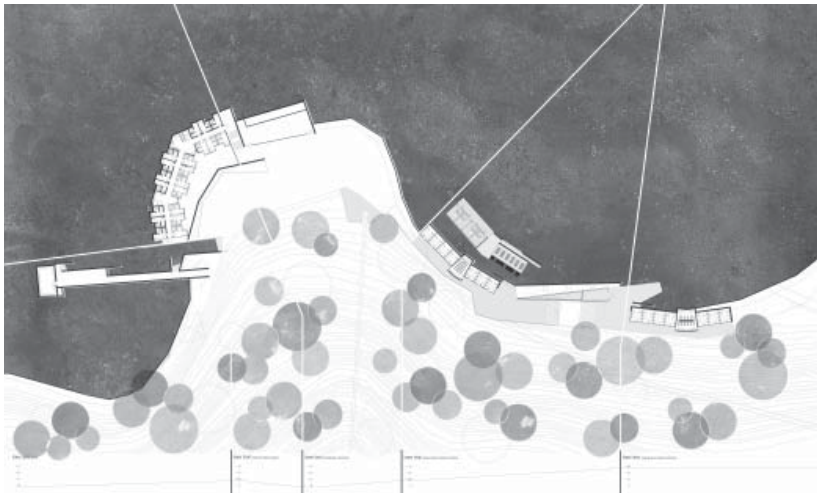

site plan orientation: the sleeping spaces and majority of the structures follow the curves and settle into the topography of the land. Over time will age and blend into the landscape.

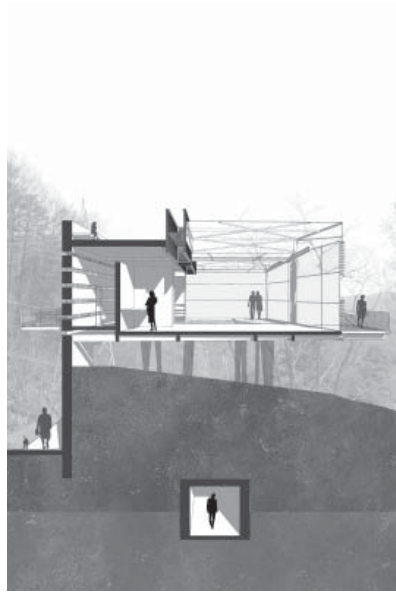

section of hill top through adjacent stairs and lightwell at archive entrance

section through lab and archive tunnel looking toward the dam



an extensive system of photo voltaic cells extend off the concrete face of the dam. the space between the panels and the dam can be occupied. a network of walkways wind behind the panels and open up at two platforms that extend out over the river. at these areas information can be gathered on the efficiency of the panels and the operations of the wind turbines.



section perspective through camper's sleeping deck

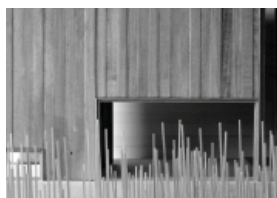
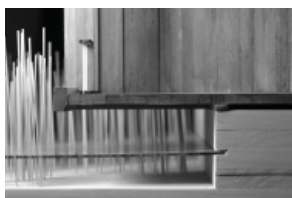

Joseph Watson

a_482 professor Tricia Stuth

of Architecture and Ethics, *Tau Sigma Delta* honorable mention

Sited in Hattiesburg, Mississippi, this women's clinic is surrounded by Sacred Heart Catholic Church and School, Court Street United Methodist Church and a suburban neighborhood. The hope is that through juxtaposition and proximity, the design can further intelligent dialog on the complex issues of reproductive rights: issues too easily reduced to black or white ideological stances.

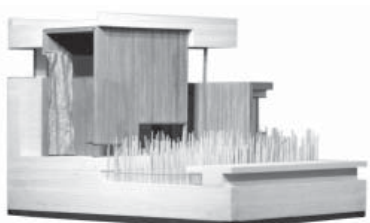

The design conceptually centers on the annunciation. Mary's encounter with the angel provides a way to view the act of sacrifice as an internal giving of one's self. The design responds to this by the simplest means. The site is divided in two: a healing garden contains a forum and medicinal herb garden, a silence garden contains the clinic. The gardens strengthen the conceptual nature of the project and provide for privacy and anonymity without the typical, banal use of walls and gates. Within the clinic spaces respond to social conditions, the annunciation and the immediate physical site.



rendering of counseling room

longitudinal section through the archives and cantilevered counseling rooms

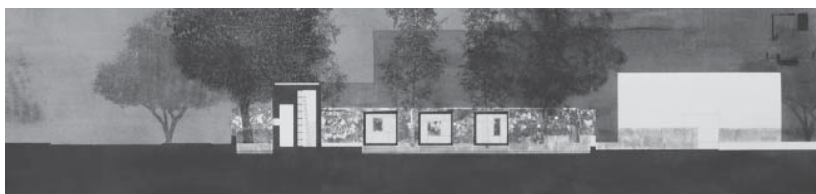

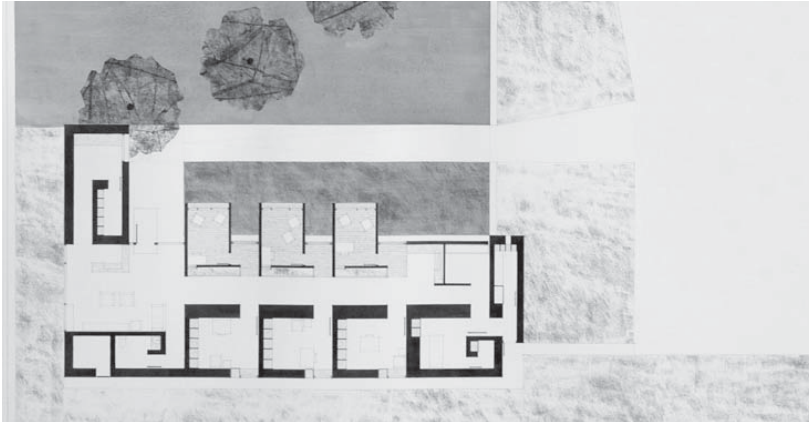

site plan

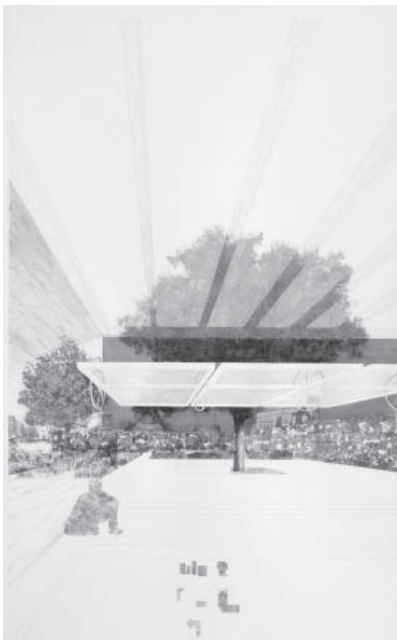

rendering of forum
looking over healing
garden



rendering of clinic

cross section through
counseling room

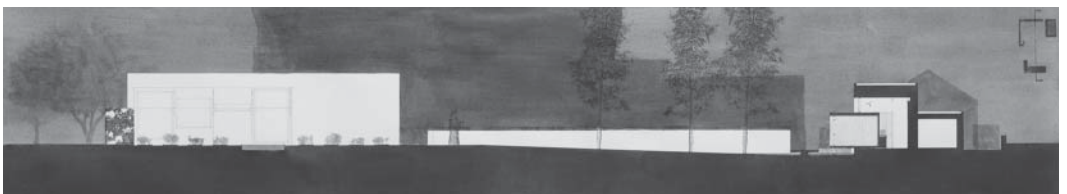



daley womack

a_482 professor tricia stuth

a house built for seeing, *tau sigma delta honorable mention*

Dr. Shoemaker, a geologist and an astronomer, proved his 'impact theory' with research and studies at the meteor crater. His research helped prove that this site was created from the impact of an extra-terrestrial object with the earth's surface. Using Dr. Shoemaker's life story as a resource, a house built for seeing creates a

retreat house for Dr. Shoemaker's family to stay as they comet hunt. Each pavilion's design is based on a phase of the moon, and they work collectively to tell a story. These pavilions are the public spaces used for night-viewing during the summer.

as people travel throughout the crater at night, the pavilions create a path to discovery. the pavilions transform the visual into the physical. upon arrival, the visitors think they understand the crater and its depths. thus, the path to discovery. after the point of birth, vision is cut off, focused, and reflected in various places to heighten an awareness of place. the crater is an interstitial space. the crater is a place within the physical environment which allows the realms of the sky, ground, and horizon to exist in the same moment of time. as the physical path begins to disappear, the pathway continues to exist after a transformation of vision. the visitors learn to make their own way back to re-birth. this pathway unveils the process of locating self within the universe.

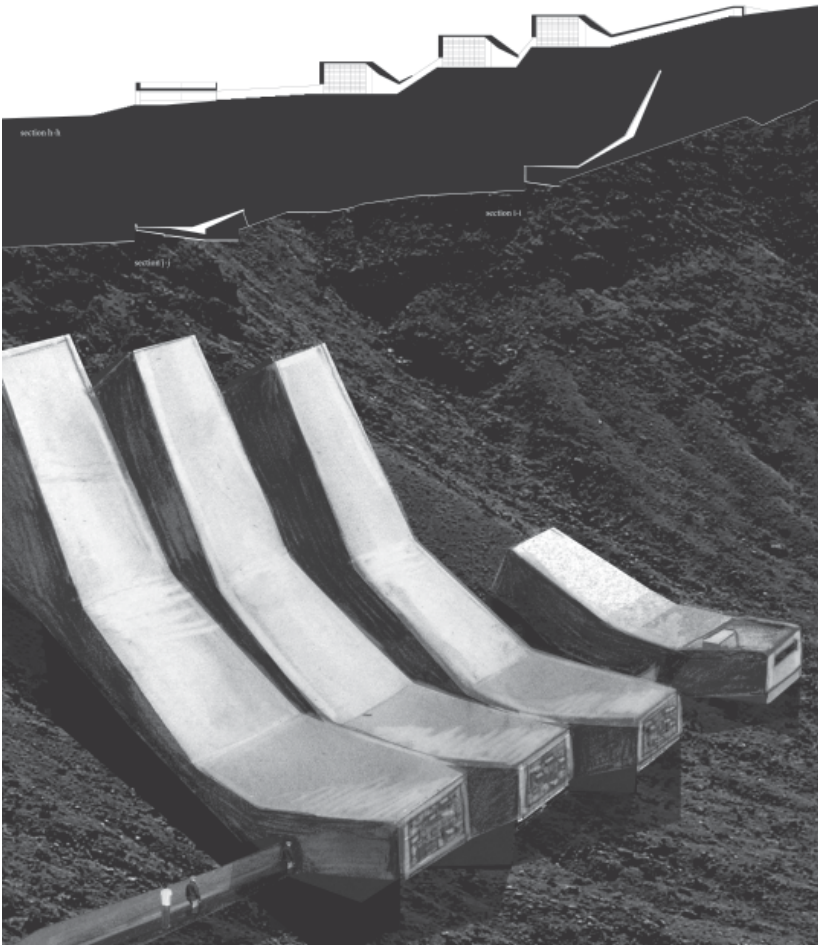

wind channels at floor of crater



re-entry of house
to washroom



beginning of pathway



entrance along 6' wall



view of stairs at exit



the retreat house and observatory for comet hunters provides spaces that thrive to be seen and experienced in different ways. the basis of the project is to create an environment that makes people aware of how they see. while the observation space is a place that encourages a visual experience, the living space contrasts the visual with a more physical relationship to its space. the constant travel between the visual and the physical heightens one's awareness of their surroundings.



natalee newcomb

a_482 professor george dodds
the texture of place

America's early 20th century industrial sites, once landmarks of industry and progress, are now abandoned and virtually unknown to current inhabitants. A prime example of this condition, Knoxville's Standard Knitting Mill, was once the most innovative and only vertically integrated knitting mill in the South. This project explores the reactivation of this site by placing a new contextually and historically conscious program that weaves into and out of the remaining cotton and knit-ware warehouse at Standard's former site. The insertion of a new innovative textiles manufacturing, educational, and museum facility uses the memory of the many people in this space to inform and further the history of this place.

Programmatically, the body of the remaining warehouse will remain a hauntingly empty space save for the massive columns and well worn cotton picking machinery. The division of spaces will change with rotating exhibits, as the fibers themselves create thresholds and boundaries.

The addition of the production and education bar reactivates the community facing façade and acts as the transitional zone between the old factory and the redeveloping neighborhood of Park Ridge. The new entry connects the museum, educational and production bar, and main axis through the neighborhood. First Creek, once the source for knitting processes within Standard Knitting Mill, is now used by the dye house and creates a visual connection between the commercial and educational programs. Across the creek, the original building's footings provide a physical connection between the public gardens beneath the new factory and educational component, by allowing students, factory workers and visitors to circulate and interact.

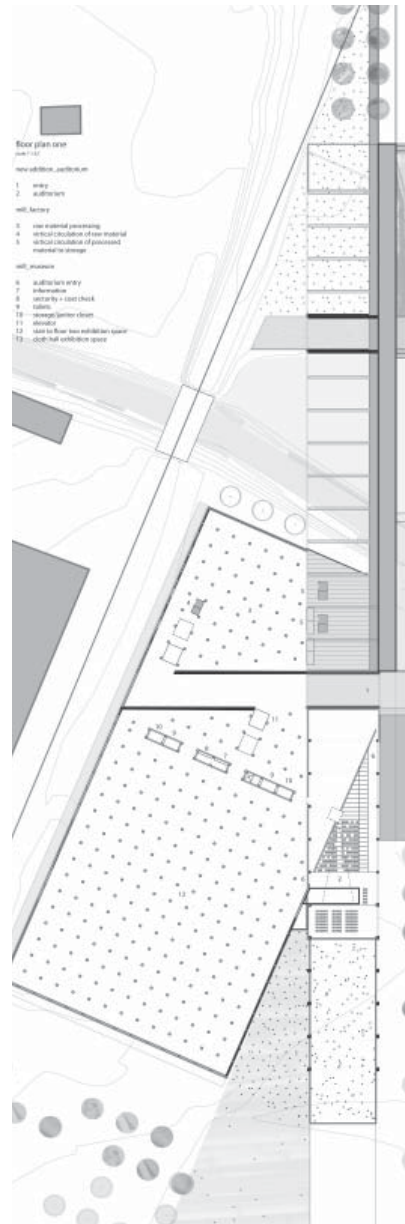

floor plan

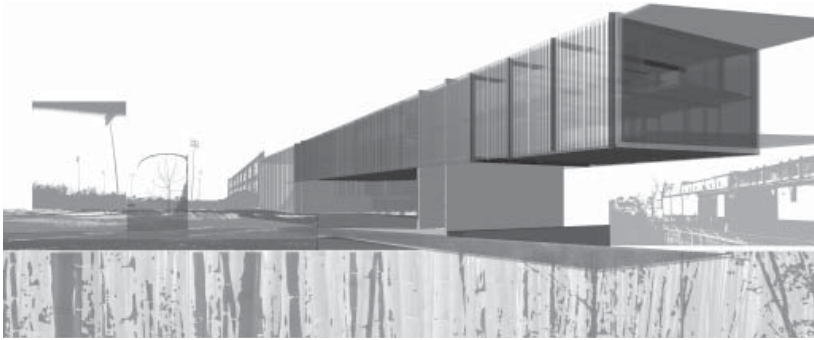

view of exterior
from garden



view of cloth hall
exhibition space



view of entry

model photograph

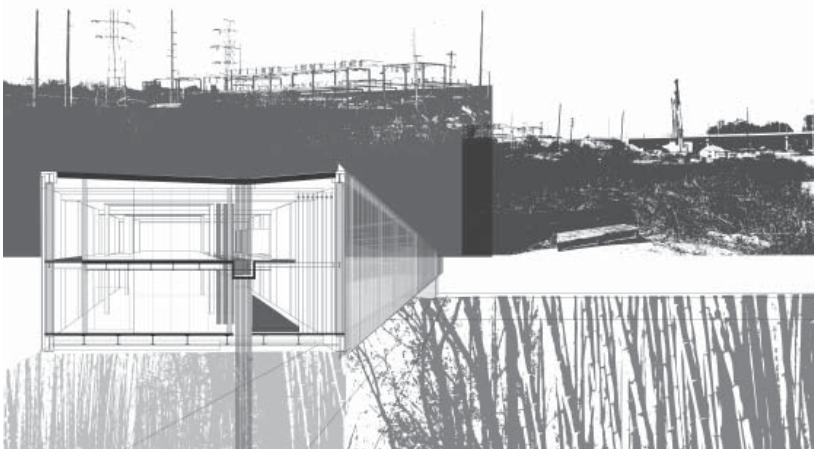

section perspective
through dye house



craig reschke

a_482 professor george dodds

two spaces one place: heterotopia and festival

Two Spaces One Place: Heterotopia and Festival investigates cultural events that are a fixture in our society and influence the places that we make. The research for this topic began with two primary readings: "Of Other Spaces" by Michel Foucault and Italo Calvino's "Invisible Cities."

The site for the project is the 57th Street Art Fair in the Hyde Park neighborhood of Chicago. In conjunction with the World's Columbian Exposition in Jackson Park, the Hyde Park neighborhood expanded rapidly - leaving buildings available at low costs to artists, some of whom started the 57th Street Art Fair. Later, during Urban Renewal, many of these shops homes and studios were torn down, destroying the spaces in which the fair was conceived, but not eradicating the fair itself.

level one plan



The goals of the project were: bring artists back to the site year round, create a cultural institution for the neighborhood, and design a site that responds to the coming and going of the festival each year. The programs selected to achieve these goals were an artist's cooperative for twelve artists, an oral history center to record the stories and ephemeral everyday events of the artists in the neighborhood, a 'shed space' to be adapted for different purposes throughout the year, and exhibition pavilions for the artists to exhibit their work throughout the year. These goals and

programs developed through zones and boundaries on the site. The expansion and contraction of the site through three zones accommodates varying amounts of inhabitants so the site can function as a festival site and an everyday living space. The boundaries on the site are physical and temporal both changing through landscaping, individuals presence on the site, or programmatic use.

The site is developed not in one way or for one program, but resolved to allow the ideas set forth by Foucault and Calvino, the actions of people, to create the many spaces that make a significant place.

both the artist's cooperative and the oral history center are located along the edge of 57th street. the artist's studio spans perpendicular to the street, allowing people to move under the studio in the first zone of the artist's landscape.



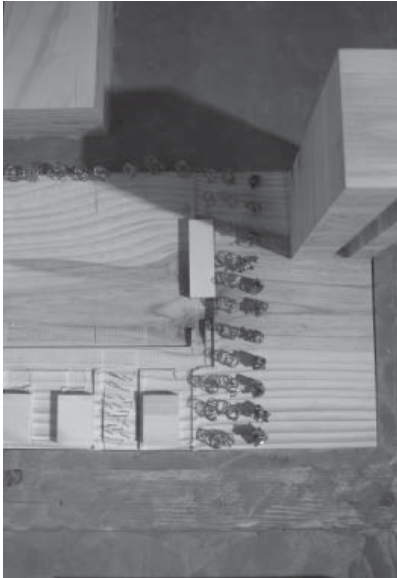

model showing
view down
kenwood avenue



model showing overhead
view of projection and
festival lawns



kenwood ave elevation



the artists oral history
center, the 'shed space'
and the artists'
pavilions sit along
kenwood avenue.



the festival landscape -
which is depressed -
into the earth - folds up
and creates a berm
along kenwood avenue
reestablishing the
street edge.



chuck draper

a_572 professor edgar stach
manna house

*"Buy the sky and sell the sky and tell the sky and
tell the sky. Don't fall on me."*

REM, "Fall On Me"

sectional perspective

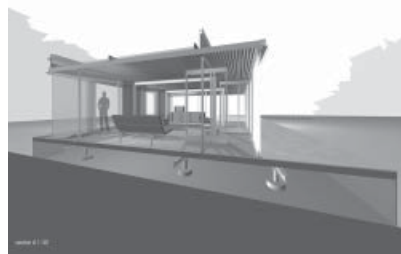

This small house was designed as part of a studio focusing on the solar decathlon competition. There are a number of active strategies utilized, but where the project succeeds most is in the passive strategies employed. The project could be seen as technological marvel, the primary solution stems from revisiting simple southern methodologies that seen everyday in and around Knoxville, Tennessee. Three sided screened porches and shotgun layouts of openings common around Knoxville because they have proven results. There is a greenhouse adjacent to the southeastern facade separated from the house by a thick glass container wall that acts as a cistern and a thermal mass. Excess rainwater is pumped from the cistern to evacuate tubes on the roof where it is heated by the sun and then passed through copper tubes in the floor for radiant heating. There is also an artificial pond that has hydroponic plants that feed halibut, which produces enriched silt that drains down the sloped basin to fertilize a small vegetable garden. The main material of the home is a translucent Kalwall panel that exhibits extraordinary thermal properties, but again is a very commonplace material found in factories and warehouses. This project as a version of southern vernacular in combination with a case study "life in a Japanese lantern" mentality.

floor plan

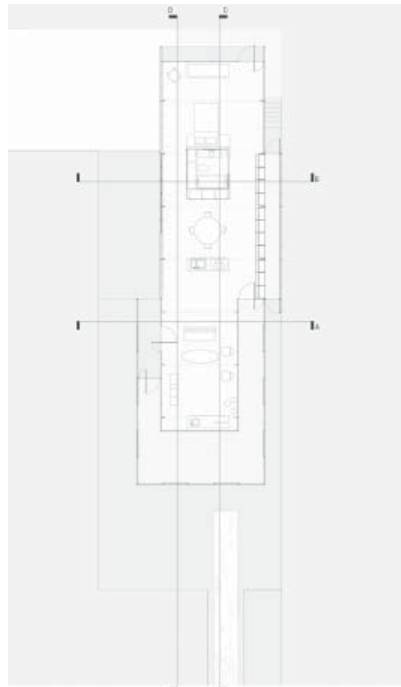

longitudinal section
through circulation



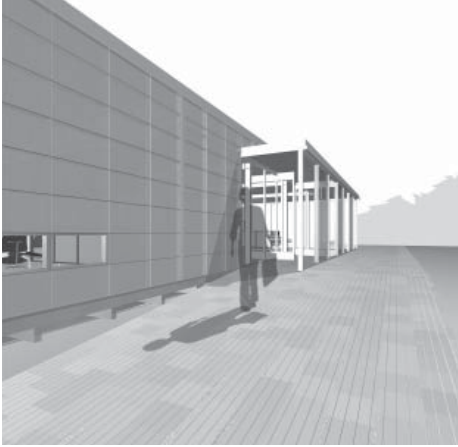

view of screen wall

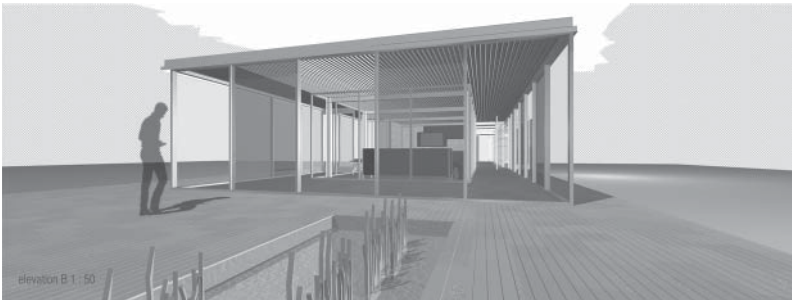

view of main entrance

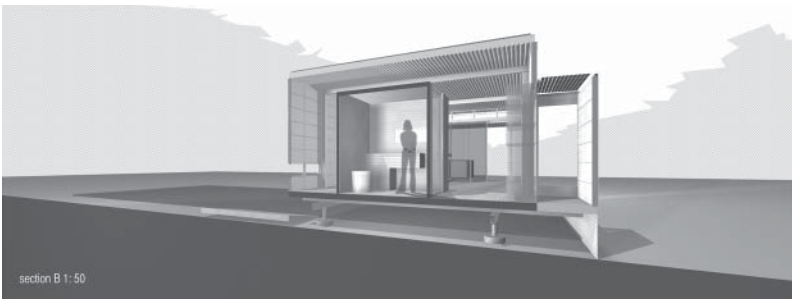

sectional perspective
through washroom

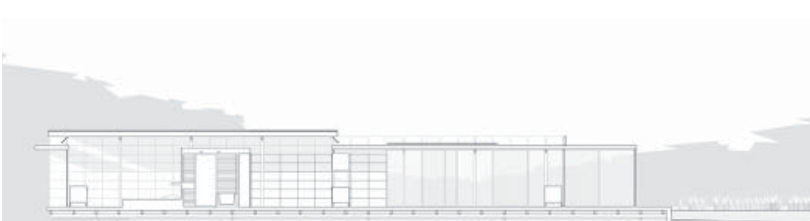

longitudinal section
through living spaces



heather cope

a_572 professor edgar stach
screen house

The essential part of this project is a living space between two screens. These screens define both indoor and outdoor spaces, and allow for both necessary privacy from and connection to the exterior. Within the screens, space is layered into three zones: a sunspace on the southeast, a living area, and a service zone to the north.

The house is designed as a kit of parts. The light frame structure is 5x7 cm steel tubing. Attached to the structure are the window screens with operable window modules and PV glass. The structure spans in between the screens to support a living area.

The southeastern PV glass facade provides energy to power the home. Sliding glass doors in the facade, as well as windows above the living area, ventilate the sunspace to avoid excess heat gain in the warmer months. The gypsum panels in the living space and service zone incorporate phase change materials to provide further control of heat.

screen system

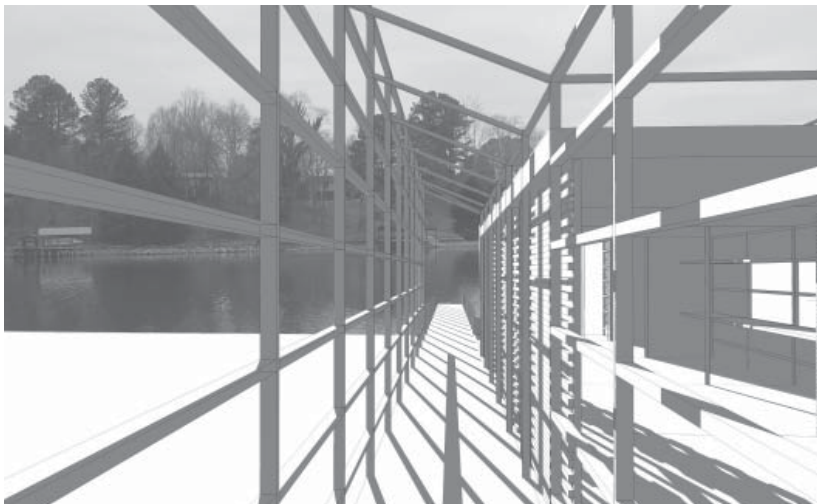
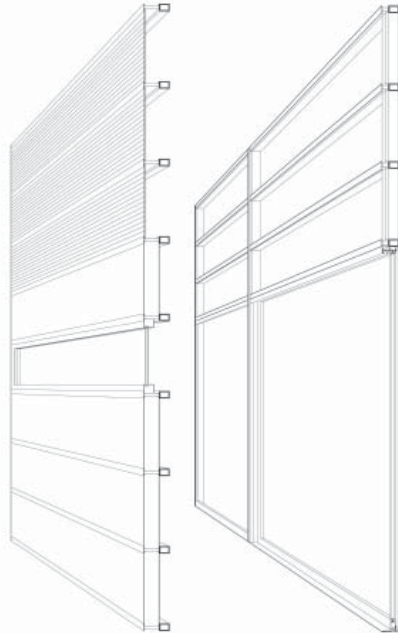

view between screens

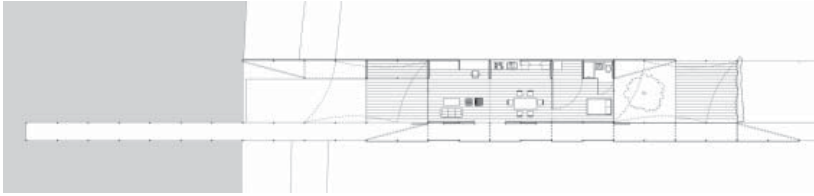

floor plan

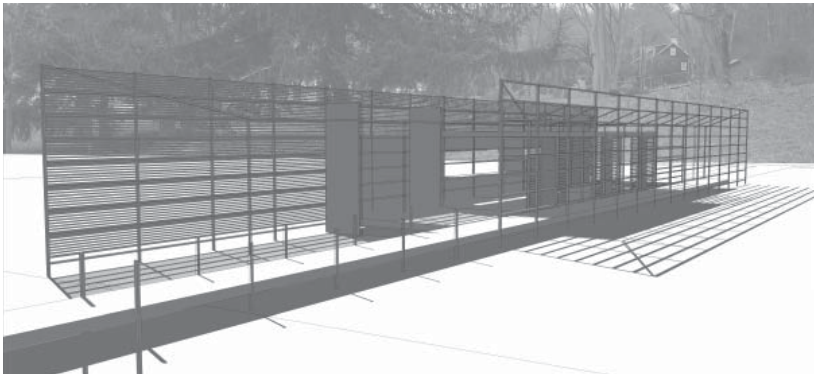

view of south
eastern facade

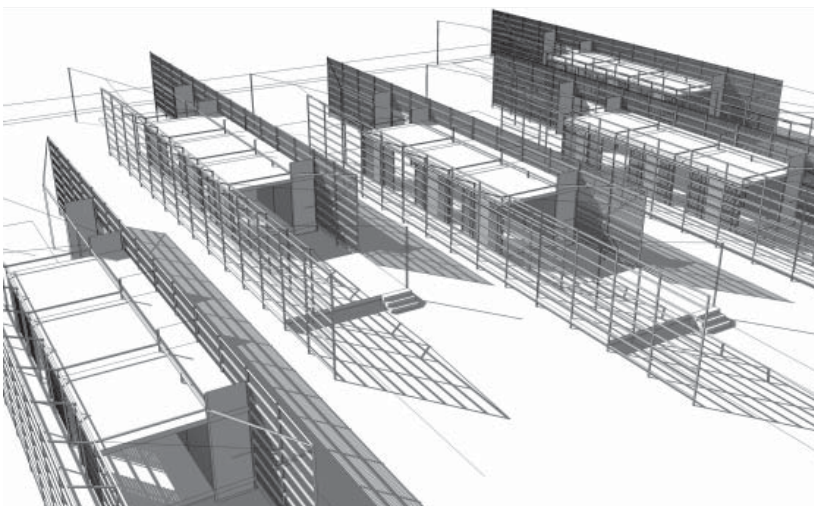

aerial perspective



patrick zimmerman

a_graduate thesis professor b. ambroziak

liminal space in architecture: threshold and transition, robert b. church iii award

A study of the liminal, or transitional, stage in cultural rites of passage, or rituals, provided an analogy for the understanding and creation of in-between space as it exists in historical architectural precedents. The knowledge gained from this investigation proposes a set of these processes, that include layering, dissolution, dissociation, and blurring inform an architecture that responds to and advances the perception of the threshold as a unique transformative space that connects two dissimilar spaces and introduces a discontinuity that heightens the spatial awareness of the occupant.

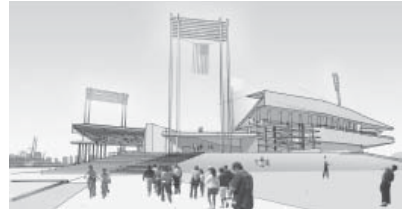

view from north pedestrian entrance

The application of these processes to the design of a baseball stadium in Miami resulted in the formation of distinct transformative thresholds at multiple scales, from the larger site context down to the building itself.

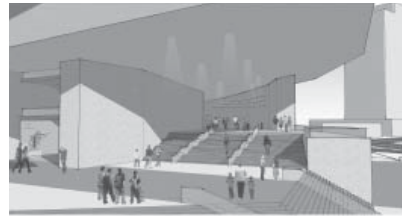

view of main entrance

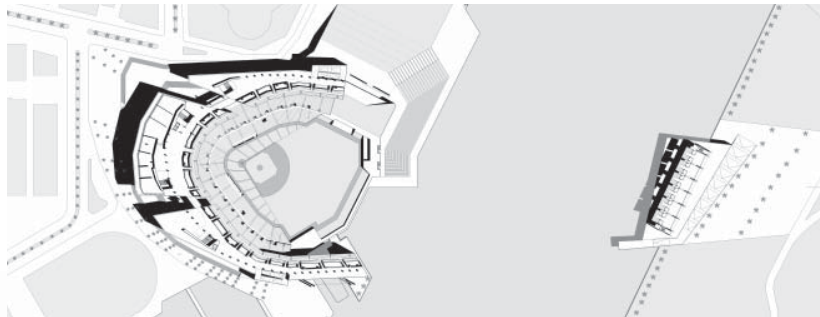

site plan

site section

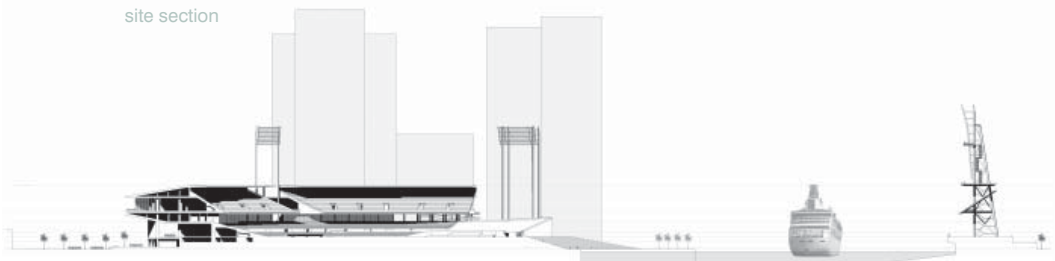

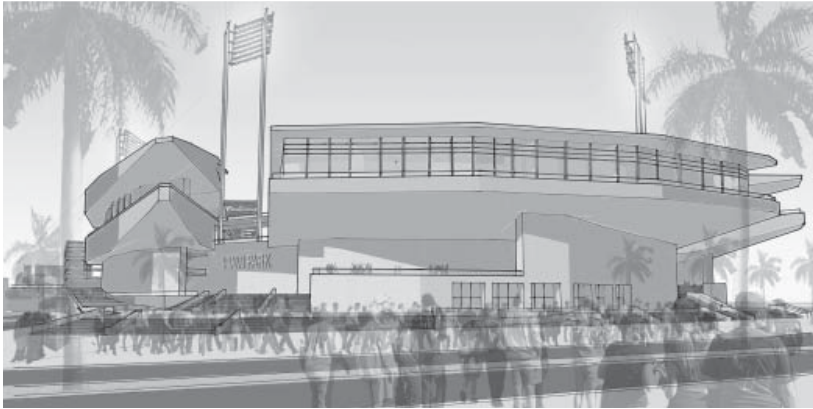

view of main entrance

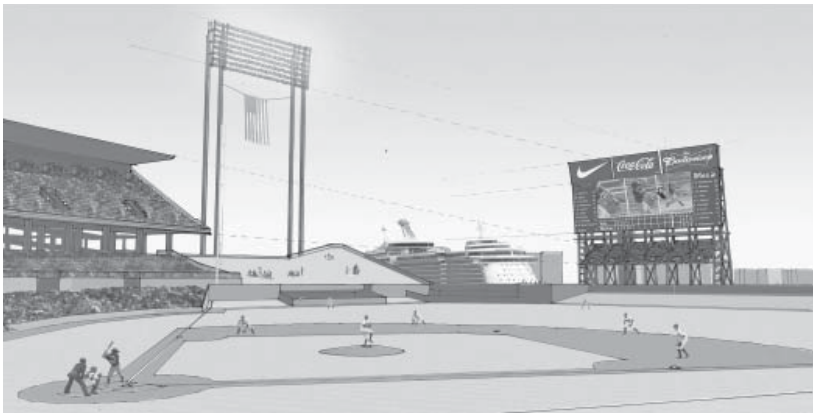

view of playing field

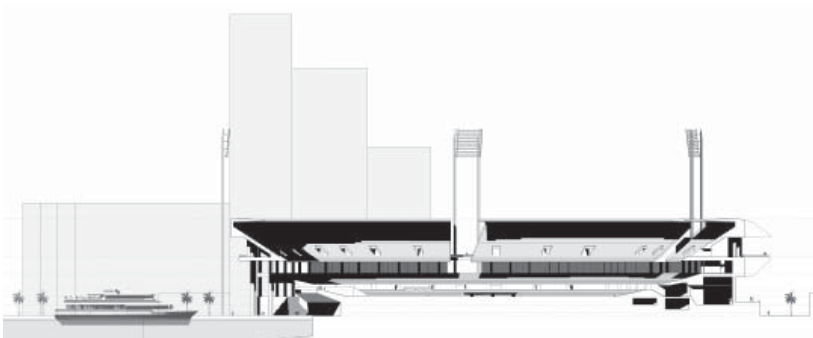

site section



office plan



bedroom plan



rebecca hand

id 272 professor jeff geren
the river eddy: cafe and gift shop

This assignment is a hybrid project for a business owner in Delano, TN who desires to build a café and gift shop that encourages the use of a nearby white water rafting site. While the building is under construction, the owner, his wife, and their son need to live in the gift shop and office while running the café. The spaces need to be not only multi-functional, but also designed in a way that will allow the family privacy from customers. To achieve this, the kitchen, office, gift shop, and base-

ment entrances are grouped together so the family can move freely between their private rooms during business hours.

A large number of windows are incorporated in the design to highlight the surrounding views and to utilize natural light. In doing this, the energy cost will be decreased. Cost effective products such as cork, local woods, and recycled glass are used to incorporate sustainability throughout the design.



plan 01
view of cafe

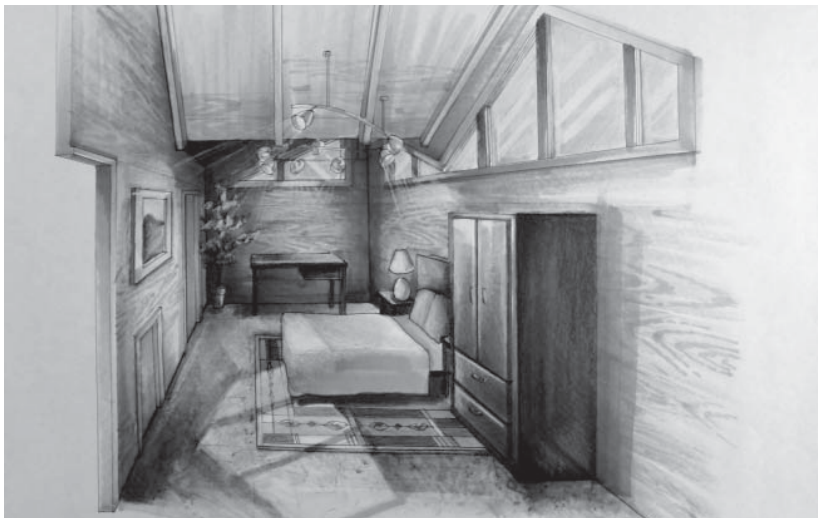

view of bedroom



plan 01



plan 02



plan 03

mark borys

id 272 professor jeff geren
hybrid project



This project is a new construction multi-use facility. The client and the family will use the structure as a residential space for the first year to year and a half, and then the family has plans to convert the space into a commercial environment. The major challenge of this project is the small footprint specified by the client. The space needs to be large enough to serve as a functional and engaging commercial setting, while still providing adequate storage and areas for private use for the family and staff working on the site.

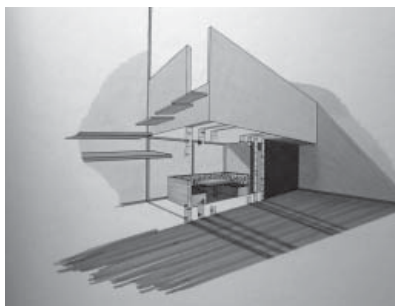

view of dining

It is important in the design approach to keep the floor plan as open as possible so customers will be encouraged to navigate and experience the main floor of the facility, and by having minimal walls, the design is also able to distinguish zones of privacy not intended for public use. This project also uses materials that are from rapidly renewable resources, recyclable materials, and materials from the site.



view of living

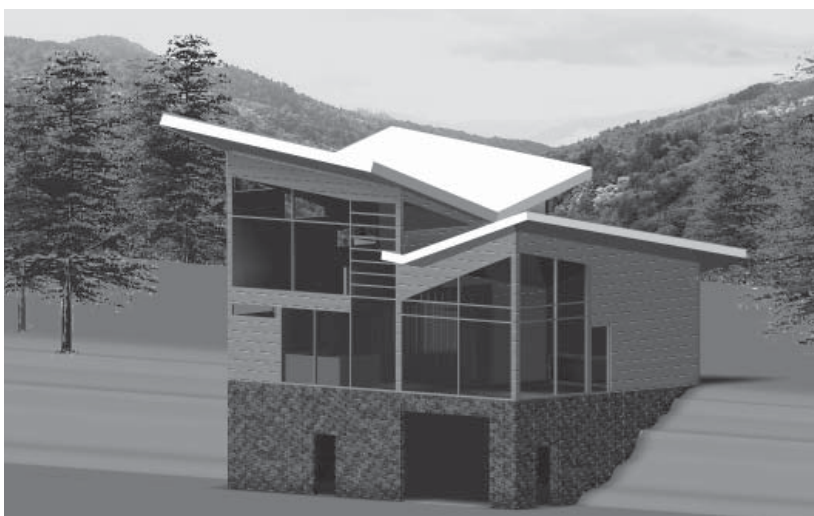

model from southwest



section a:a

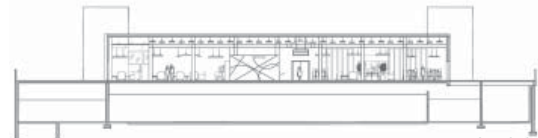

section b:b



bonnie casamassima

id_371 professor margaret denney

lincoln memorial university student center

The assignment focuses on extensive research and programming which involved site visits and multiple client interviews. The acquired information was then applied to the renovation of the existing student center at Lincoln Memorial University. The space is to be inspiring, welcoming and energetic. It is to include a bookstore, study areas, a dinner theatre, cafe, game room, and lounge spaces. Above all, the spaces must demonstrate adherence to codes and display extreme convertibility to accommodate the future growth and needs of the university.

The design exhibits flexibility of spaces by paying close attention to the adjacencies of the spaces and their intended use. For example, the design implements minimal permanent walls. In addition, a sliding wall system between the dinner theatre and the café is implemented. This allows maximum convertibility between all spaces. Both the dinner theatre and café have a close adjacency to the outdoor space which allows optimum flexibility of use. Above all, the design represents the active, studious and vibrant attitude of the students of Lincoln Memorial University.



view of cafe
view of lounge

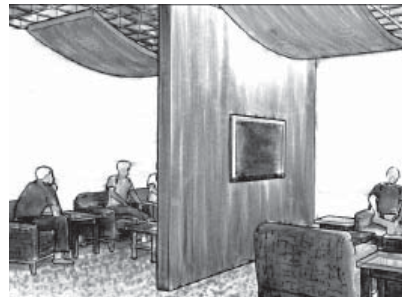

second level floorplan

tori barnes and kate lough
id_372 professor melanie doss
cancer treatment facility



This prototype for a cancer facility is the result of a semester's work of wellness research. The project team was provided with an existing footprint only after developing a programming book that thoroughly examined staffing needs for the typical healthcare environment, equipment standards, and a variety of factors contributing to the patients' overall health. The understanding of certain colors and materials, as well as the patient's need to participate in a variety of daily therapeutic and social activities were crucial to the design of the center.

The resulting plan is a combination of carefully considered agencies, equipment needs, and the structural requirements of that equipment. The design and concept centers around those therapeutic and social needs of the patients through a Learning Center, located on the first of three floors, that will provide healing through education. This area is accessible by both patients and their families, who will use the center as a research, private library, counseling, or seminar space.

Upper floors are separated into radiation and chemotherapy floors, which include short-term and long-term patient rooms. Also included are art and massage therapy spaces, a workout center, and an access to an adjacent facility including kitchens, and childcare.



first level floorplan

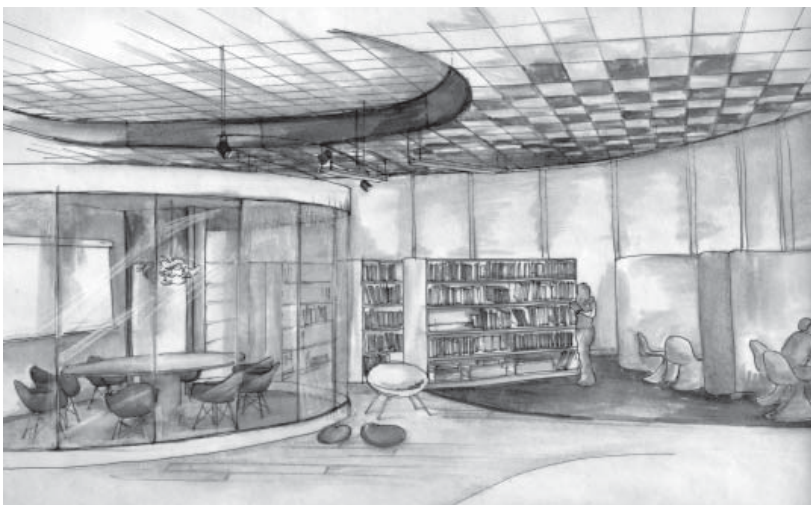

view of learning center



emily fly-phillips

id_472 instructor diane riely
port de naufrage spa and resort

This interior design studio focused on the design of a large resort. The programming and design included retail, fine dining, and hospitality. Students were given the opportunity to choose a location that would be pertinent to our concept. I chose Canada for its cold weather, beauty, and rustic appeal. With this decision the concept for the resort was Restored Rustic.

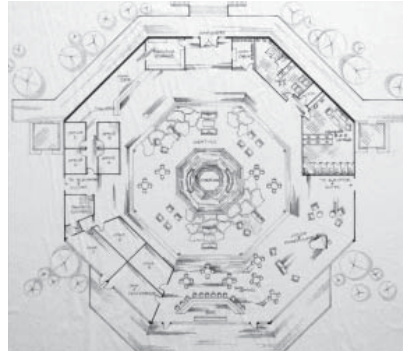

plan of resort

The design of the main building is centered around a fire pit hood that is complemented by a large open view of the trees, and the water that fills Ontario's Big Tub Harbor. Following this concept, a smaller, yet familiar space for the 5,000 square foot fine dining restaurant was created. Rustic and modern design of the spaces provided the client with a comfortable and intimate atmosphere and a warm ambiance. The concept for the 5,000 square foot retail space was to bring the surrounding nature into the design; therefore it exhibited organic clothes, materials, and displays.

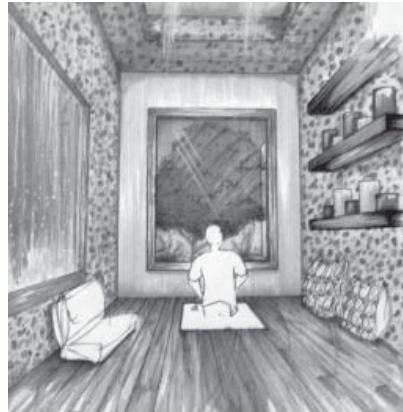

view of meditation space

To design a relaxing 10,000 square foot spa, I chose symmetry to provide a non threatening place to come and relax. The materials used were consistent in concept and tone to the resort as a whole, but functioned as its own getaway. In designing each of these spaces, function, comfort, and aesthetic appeal intermingled to provide each guest with a comfortable and memorable experience.



view of spa

view of hospitality space



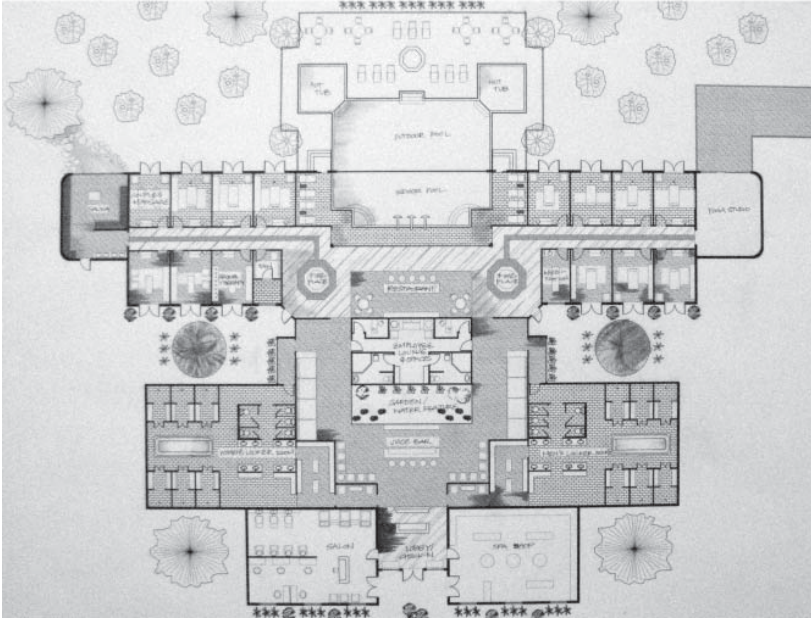

plan of spa



view of dining

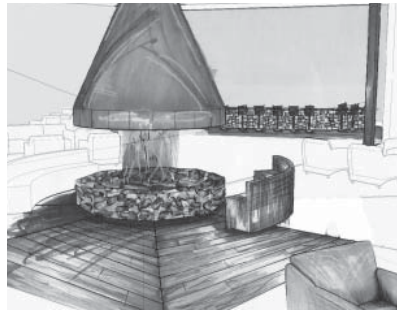

view of center fireplace

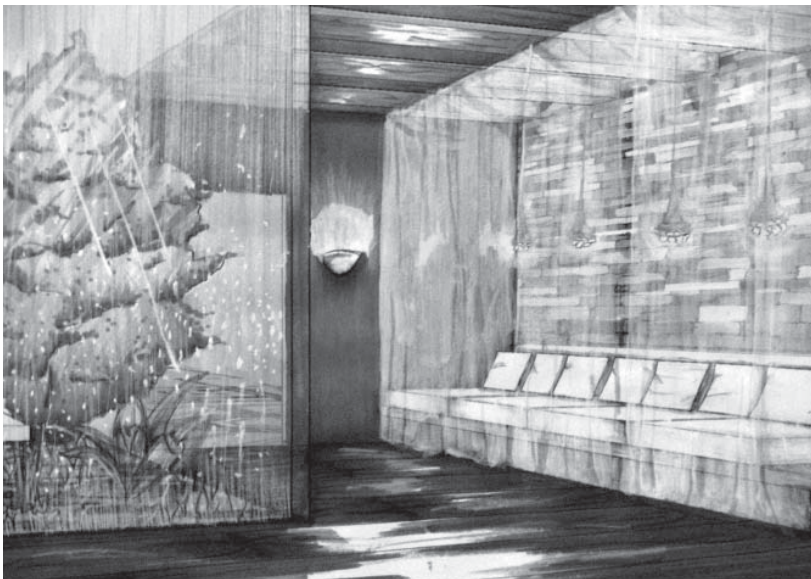

view of spa lounge

the grand tour: the gulf of finland

summer 2007 professors ted shelton and tricia stuth
stockholm, helsinki, st. petersburg, tallinn

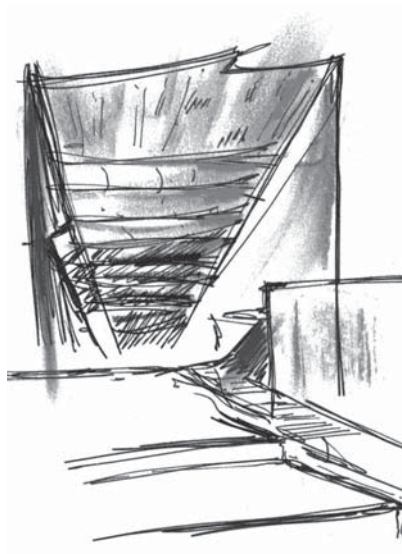

kyle campbell
old city, tallinn



ashley bigham
aalto auditorium



janie wright
aalto's studio



lauren trotter
soviet housing



jessica jolley
ottomimi chapel



aaron mckenzie

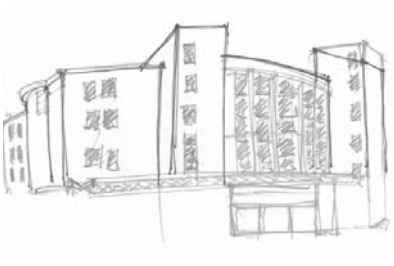

megan lynch
palace of culture



lance thorton
aalto's home



samuel mortimer
aalto auditorium



curtis jennings
tallinn, estonia



alex pisha
old city, tallinn

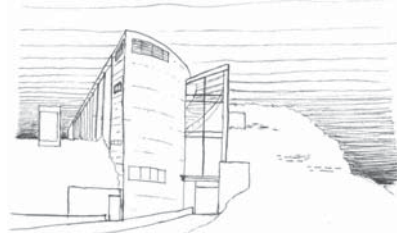

alex liedl
kumu museum

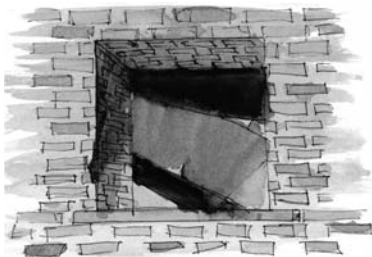

lauren rogers
church of st. mark

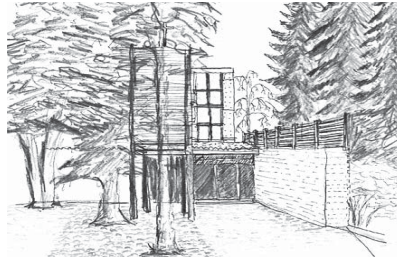

josh jorgensen
ottomimi chapel

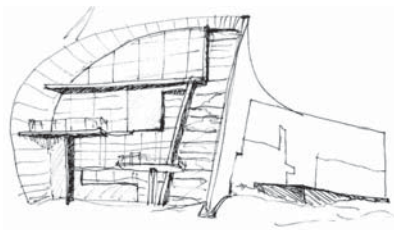

michael clapp
kiasma museum



dean mckenzie
aalto's home

lecture series
robert b. church III memorial lecture series
fall 2007- spring 2008

john dixon hunt	09.17.07
the disappearing margin: the issue of meaning in modern landscape architecture	
john ronan	10.08.07
connections	
brian mackay-lyons	10.22.07
willing paradises	
patricia patkau	10.29.07
2+5+2	
randy brown	11.05.07
architect as developer	
brian ambroziak	11.12.07
tactics and trajectories	
max robinson	02.04.08
<i>...but is it ARCHITECTURE?</i>	
trey trahan	03.03.08
defining local	
karim rashid	03.07.08
general shale lecture the new global design landscape	
dietrich neumann	03.10.08
the architecture of the night	
janet abrams	03.31.08
joint sponsorship with the university of tennessee art department the spaces between: using maps to make arguments and processes visible	
stefano riccioni	04.07.08
epiconography: a new approach to the history of art and sponsorship with the university of tennessee school of art, classics department, history department, and the marco institute for medieval and renaissance studies	
elizabeth k. meyer	04.14.08
sustaining beauty: a manifesto on the performance of appearance	



awards and scholarships

AWARDING OF HONORS 2008 INTERIOR DESIGN

Outstanding Student Award
Outstanding Senior Recognition
Letters of Merit

Meredith Avie Hurst
Erin Kathleen Joiner
Morgan Clark Boling
Allison Janeen Davis
Melissa Meredith Frame
Erin Kathleen Joiner

International Interior Design
Association Award
American Society of Interior Designers
Certificate of Merit
Chancellor's Citation for Extraordinary
Academic Achievement
Collegiate All-American Scholar Award
Top Collegiate Scholar

Laura Kimberly Walker

Meredith Avie Hurst

Laura Kimberly Walker
Kathryn Anne Ryan
Laura Kimberly Walker

STUDENT RECOGNITION INTERIOR DESIGN

Valedictorian
Magna Cum Laude
Cum Laude

Laura Kimberly Walker
Laura Kimberly Walker
Erin Kathleen Joiner
Melissa Mustafa
Lauren Elizabeth Shackelford
Kathryn Eleanor Tomisek

Outstanding Achievement Award

1st Year
2nd Year
3rd Year

Kathryn Eleanor Tomisek
Laura Kimberly Walker
Laura Kimberly Walker
Kathryn Eleanor Tomisek

Tau Sigma Delta Honor Society
National Society of Collegiate Scholars

Kathryn Eleanor Tomisek
Allison Jeneen Davis
Erin Kathleen Joiner
Kathryn Anne Ryan
Kathryn Eleanor Tomisek

National Scholars Honor Society
Phi Eta Sigma National Honor Society
Gamma Beta Phi National Honor Society
Phi Sigma Theta National Honor Society
Dean's Student Advisory Council
American Society of Interior Designers

Kathryn Anne Ryan
Erin Kathleen Joiner
Kathryn Eleanor Tomisek
Kathryn Anne Ryan
Kathryn Eleanor Tomisek
Emily Ann Hodes Cuba
Allison Janeen Davis
Lynsey Elizabeth Dedrick
Michelle Ryan Espinosa
Meredith Chase Henry
Meredith Avie Hurst

National Deans List
Minor in Art History

Melissa Mustafa
Kathryn Eleanor Tomisek
Kathryn Anne Ryan
Kathryn Anne Ryan
Laura Kimberly Walker

INTERNAL SCHOLARSHIPS INTERIOR DESIGN

Manfred and Fern Steinfeld Scholarship
in Interior Design

Meredith Chase Henry
Erin Kathleen Joiner

EXTERNAL SCHOLARSHIPS INTERIOR DESIGN

Pi Beta Phi Foundation Scholarship
University Scholarship

Emily Ann Hodes Cuba
Allison Janeen Davis
Meredith Avie Hurst
Jennifer Megan Jobe
Laura Kimberly Walker
Lynsey Elizabeth Dedrick
Meredith Avie Henry
Jennifer Megan Jobe
Melissa Mustafa
Kira Elizabeth Perkins
Lauren Elizabeth Shackelford
Kathryn Eleanor Tomisek
Melissa Mustafa
Meredith Chase Henry

Hope Scholarship

Hop Bailey Sr. Scholarship
OMS Scholarship

AWARDING OF HONORS 2008 BACHELOR OF ARCHITECTURE

The Tau Sigma Delta Bronze Medal

Medal Awardee:
Dianna Rhea Morelock
Honorable Mention 2nd place:
Joseph Michael Watson
Honorable Mention 3rd place:
Anna Daley Womack
Dianna Rhea Morelock
Craig Michael Reschke
Joseph Michael Watson
Anna Daley Womack
Medal Awardee:
Michael Alan Davis
Certificate of Merit Awardee:
Meghan Blaire McCrary
Michael Betsy Kenney
Craig Michael Reschke

School of Architecture Faculty
Letters of Excellence

Henry Adams AIA

Alpha Rho Chi Medal

Chancellor's Citation for Extraordinary
Academic Achievement

Michael Alan Davis

Chancellor's Citation for Extraordinary
Professional Promise
Top Collegiate Scholar
Minor in Business

Minor in Dance
Minor in Plant Science
Minor in Psychology
Outstanding Achievement Award

Creative Achievement Award
AIA Tennessee Design Award
UT Chancellor's Gene Mitchell Gray
Pioneer Award

Michael Alan Davis
Michael Alan Davis
Joseph McArthur Cole
William Craig Crawford
Dianna Rhea Morelock
John Collin Williams
Meghan Kathleen Bailey
Bethany Margaret Morris
Monica Lauren Verastegui
Michael Alan Davis
Jamison William Hupp
Jamison William Hupp
Monica Lauren Verastegui

Joseph McArthur Cole

STUDENT RECOGNITION BACHELOR OF ARCHITECTURE

Valedictorian
Summa Cum Laude

Magna Cum Laude

Cum Laude

Tau Sigma Delta Honor Society

National Society of Collegiate Scholars

Phi Sigma Theta National Honor Society
Phi Sigma Theta National Honor Society

Michael Alan Davis
Michael Alan Davis
Meghan Blaire McCrary
Katherine Tyler Martin
Matthew Brandon Parks
Craig Michael Reschke
Sveta Lana Sorin
Rachael Layman Spangler
Joseph Michael Watson
Emily Ann Bradley
Brenda Anne Malone
Dianna Rhea Morelock
Geoffrey John Overmyer
Rachael Lillian Stollar
Geoffrey Scoot Acker
Emily Ann Bradley
William Craig Crawford
Michael Alan Davis
Brenda Anne Malone
Katherine Tyler Martin
Meghan Blaire McCrary
Dianna Rhea Morelock
Matthew Brandon Parks
Craig Michael Reschke
Sveta Lana Sorin
Rachael Layman Spangler
Joseph Michael Watson
Thomas Alexander Allen
Matthew John Lewis
William Alexander Roehl
Sveta Lana Sorin
Monica Lauren Verastegui
Jesse Ian Galbraith
Thomas Alexander Allen

Phi Eta Sigma National Honor Society	Geoffrey Scott Acker Thomas Alexander Allen Matthew John Lewis Katherine Tyler Martin Meghan Blaire McCrary Matthew Brandon Parks William Alexander Roehl Monica Lauren Verastegui
Gamma Beta Phi National Honor Society	Joseph McArthur Cole
Phi Theta Kappa Honor Society	Brenda Anne Malone
ZTA Pearl Society	Michael Alan Davis Monica Lauren Verastegui
French National Honor Society	Sveta Lana Sorin
Outstanding Achievement Award	
1st Year	Katherine Tyler Martin
2nd Year	Rachael Layman Spangler
3rd Year	Michael Alan Davis
4th Year	Michael Alan Davis Meghan McCrary
Exhibition of Undergraduate Research and Creative Achievement	Scott Michael Brelsford Matthew John Lewis (award winner) Craig Michael Reschke (award winner) Laura Felker Timberlake
Dean's Student Advisory Council	Craig Michael Reschke David Allen Scott
The Annual All-college Spring Thing (TAAST) Committee	Mary Elizabeth Eisenhauer
College of Architecture and Design Student Journal: <i>current</i>	Matthew John Lewis Craig Michael Reschke
American Institute of Architects Student Chapter	Brenda Anne Malone Meghan Blaire McCrary Bethany Margaret Morris Dianna Rhea Morelock Debora Natalee Newcombe Sveta Lana Sorin Monica Lauren Verastegui
National Organization of Minority Architecture Students	Joseph McArthur Cole Benjamin Garrett Luttrell Sherman Arthur Matthews Debora Natalee Newcombe Jon-Michael Willingham

INTERNAL AWARDS BACHELOR OF ARCHITECTURE

AIA Middle Tennessee Design Award	Michael Alan Davis Andrew William Holcomb Dianna Rhea Morelock Casey Akira Pendleton
Alma and Hal Reagan Scholarship	Joseph Michael Watson Emily Ann Bradley Michael Alan Davis Rachael Layman Spangler

Barber and McMurray Scholarship for Excellence in Architecture	Craig Michael Reschke
Bullock, Smith, & Partners International Travel Scholarship	Meghan Blaire McCrary
Christine Lynch Memorial Travel Abroad Scholarship	Sveta Lana Sorin
General Shale Scholarship	Emily Ann Bradley Meghan Blaire McCrary Rachael Layman Spangler
Ed Meiers Memorial Scholarship	Sveta Lana Sorin
Foreign Studies Enrichment Scholarship	Matthew Brandon Parks
Hastings Architecture Associates Scholarship	Joseph Michael Watson
Helen Bickford Vreeland Endowment Fund	Katherine Tyler Martin
Herbert Bebb Scholarship	Michael Alan Davis
Hnedak Bobo Group, Inc. Fellowship	Jon-Michael Willingham
Nell Mann Brown Scholarship	Bethany Margaret Morris
Marian Moffett Travel Scholarship	Dianna Rhea Morelock Bethany Margaret Morris Debora Natalee Newcombe Rachael Layman Spangler
Mark Freeman Associates Scholarship	Andrew William Holcomb
Zukerman Family Scholarship	Michael Alan Davis Brenda Anne Malone Matthew Brandon Parks Craig Michael Reschke Sveta Lana Sorin Joseph Michael Watson
Robert Seals Scholarship	Dianna Rhea Morelock Michael David Prater
School of Architecture General Scholarship	Emily Ann Bradley Brenda Anne Malone Craig Michael Reschke Sveta Lana Sorin
School of Architecture Faculty Scholarship	Drew Armstrong Balzer
Trevor S. Lee Scholarship	Bethany Margaret Morris

EXTERNAL AWARDS BACHELOR OF ARCHITECTURE

AAIG Incentive Grant	Sherman Arthur Matthews
African American Achievers Scholarship	Joseph McArthur Cole
Alpha Gamma Rho Scholarship	William Craig Crawford
American Challenge Grant	Joseph McArthur Cole
Anderson- Robinson Scholarship	Katherine Tyler Martin
Eastern Star Scholarship	Melissa Ann Bullion
Ed Scholar Scholarship	Anna Daley Womack
Elizabeth Buford Sheperd Scholarship	Anna Daley Womack
Elks Lodge Scholarship	Todd Adam Mize
Elsie P. Alexander Scholarship	Matthew John Lewis
Fred M. Roddy Scholarship	Brendan Patrick Lawton
George W. Gleaves Scholarship	Geoffrey John Overmyer

Hope Scholarship

Meghan Kathleen Bailey
Ernest Dale Brackeen, II
Joseph McArthur Cole
Michael Alan Davis
Amy Michele Hardin
Brendan Patrick Lawton
Katherine Tyler Martin
Sherman Arthur Matthews
Meghan Blaire McCrary
William Alexander Roehl
Sveta Lana Sorin
Kathryn Eleanor Tomisek
Anna Daley Womack
Meghan Blaire McCrary
Christopher Lee Buchanan
Michael Alan Davis
Brenda Anne Malone

Katherine Frierson Memorial Scholarship
National Science Scholarship
Ned McWherter Memorial Scholarship
Nestle Scholarship
Senator Herbert S. Walters
Memorial Scholarship
State of Tennessee Scholarship
Temken Scholarship
University Scholarship

William Alexander Roehl
Sveta Lana Sorin
Todd Adam Mize
Meghan Kathleen Bailey
Matthew Brandon Parks
Brendan Patrick Lawton
Laura Felker Timberlake
Joseph Michael Watson
Michael Alan Davis
Katherine Tyler Martin
William Craig Crawford
William Craig Crawford
Laura Felker Timberlake
Monica Lauren Verastegui

UT Bicentennial Scholarship
UT Parents Association Scholarship
UT Presidential Scholarship
UT Trustees Scholarship

AWARDING OF HONORS MASTER OF ARCHITECTURE

Robert B. Church III Graduate Award
Henry Adams AIA

Patrick T. Zimmerman
Medal Awardee:
Patrick T. Zimmerman
Certificate of Merit Awardee:
Brian J. Cutler
Patrick T. Zimmerman

Top Collegiate Scholar

STUDENT RECOGNITION MASTER OF ARCHITECTURE

American Institute of Architects
National Society of Collegiate Scholars
Phi Eta Sigma National Honor Society
Tau Sigma Delta Honor Society

James R. Maveety
Michelle R. Barton
Michelle R. Barton
Brian J. Cutler
Patrick T. Zimmerman

Outstanding Achievement Award

1st Year
2nd Year

Jennifer M. Bradley
Patrick T. Zimmerman

**INTERNAL SCHOLARSHIPS
MASTER OF ARCHITECTURE**

General Shale Scholarship	Jennifer M. Bradley Luke A. Sims
Archie and Judy Ellerthorpe Scholarship School of Architecture General Scholarship	Jennifer M. Bradley Luke A. Sims

**EXTERNAL SCHOLARSHIPS
MASTER OF ARCHITECTURE**

Lloyd E. Stalker Scholarship	Michelle R. Barton
------------------------------	--------------------

**BACHELOR OF SCIENCE
INTERIOR DESIGN**

Morgan Clark Bolin	<i>Knoxville, TN</i>
Emily Anne Hodes Cub	<i>St. Louis, MO</i>
Allison Janeen Davis	<i>Gallatin, TN</i>
Lynsey Elizabeth Dedrick	<i>Pittsburg, PA</i>
Michelle Ryan Espinosa	<i>Myrtle Beach, SC</i>
Melissa Meredith Frame	<i>Memphis, TN</i>
Ashley Danyale Gipson	<i>LaFollette, TN</i>
Meredith Chase Henry	<i>Powell, TN</i>
Meredith Avie Hurst	<i>Murfreesboro, TN</i>
Jennifer Megan Jobe	<i>Lewisburg, TN</i>
Erin Kathleen Joiner	<i>Hickory, NC</i>
Leslie Michelle Lahti	<i>Raleigh, NC</i>
Melissa Mustafa	<i>Powell, TN</i>
Kira Elizabeth Perkins	<i>Knoxville, TN</i>
Emily Carole Phillips	<i>Nashville, TN</i>
Kathryn Anne Ryan	<i>Germantown, TN</i>
Lauren Elizabeth Shackelford	<i>Knoxville, TN</i>
Kathryn Eleanor Tomisek	<i>Chattanooga, TN</i>
Laura Kimberly Walker	<i>Simpsonville, SC</i>

BACHELOR OF ARCHITECTURE

Geoffrey Scott Acker	<i>Lincolnton, NC</i>
Thomas Alexander Allen	<i>Charleston, WV</i>
Benjamin Scott Ashley	<i>Spencer, WV</i>
Meghan Kathleen Bailey	<i>Knoxville, TN</i>
Drew Armstrong Balzer	<i>Roanoke, VA</i>
Jarrett Bryant Benson	<i>Knoxville, TN</i>
Ernest Dale Brackeen, II	<i>Murfreesboro, TN</i>
Emily Ann Bradley	<i>Cordele, GA</i>
Scott Michael Brelsford	<i>Hendersonville, TN</i>
Christopher Lee Buchanan	<i>Alcoa, TN</i>
Melissa Ann Bullion	<i>McEwen, TN</i>
Benjamin Adam Ceravalo	<i>Martinsburg, WV</i>
Joseph McArthur Cole	<i>Nashville, TN</i>
William Craig Crawford	<i>Champmansboro, TN</i>
Michael Alan Davis	<i>Tullahoma, TN</i>
Matthew Ryan Delany	<i>Hermitage, TN</i>
Mary Elizabeth Eisenhauer	<i>Charleston, WV</i>
Jesse Ian Galbraith	<i>Colorado Springs, CO</i>
Russell Stephen Guest	<i>Charleston, WV</i>
Amy Michele Hardin	<i>Newbern, TN</i>
Andrew William Holcomb	<i>Frederichsburg, VA</i>
Jamison William Hupp	<i>Buckhannon, WV</i>
Michael Betsy Kenney	<i>Knoxville, TN</i>
Elizabeth Dawn Keyt	<i>Johnson City, TN</i>
Luke K. Kim	<i>Brentwood, TN</i>
Brendan Patrick Lawton	<i>Germantown, TN</i>
Matthew John Lewis	<i>Paris, TN</i>
Benjamin Garrett Luttrell	<i>Sneedville, TN</i>
Branda Anne Malone	<i>Minier, IL</i>
Katherine Tyler Martin	<i>Franklin, TN</i>
Sherman Arthur Matthews	<i>Knoxville, TN</i>
Meghan Blaire McCrary	<i>Knoxville, TN</i>
Todd Adam Mize	<i>Pulaski, TN</i>
Dianna Rhea Morelock	<i>Vonore, TN</i>
Bethany Margaret Morris	<i>Duck, WV</i>
Debora Natalee Newcombe	<i>Knoxville, TN</i>
Geoffrey John Overmyer	<i>Knoxville, TN</i>
Matthew Brandon Parks	<i>Benton, TN</i>
Casey Akira Pendleton	<i>Memphis, TN</i>
Michael Davis Prater	<i>Chattanooga, TN</i>
Craig Michael Reschke	<i>Woodstock, IL</i>
Mary Straughn Robson	<i>Scott Depot, WV</i>
William Alexander Roehl	<i>Knoxville, TN</i>
David Allen Scott	<i>Brentwood, TN</i>
Sveta Lana Sorn	<i>Nashville, TN</i>
Rachael Layman Spangler	<i>Knoxville, TN</i>
Rachael Lillian Stollar	<i>Winfield, WV</i>
Earl Scott Terry	<i>Knoxville, TN</i>
Laura Felker Timberlake	<i>Mt. Juliet, TN</i>
Monica Lauren Verastegui	<i>Knoxville, TN</i>
Joseph Michael Watson	<i>Memphis, TN</i>
John Collin Williams	<i>Memphis, TN</i>
Jon-Michael Willingham	<i>Nashville, TN</i>
Anna Daley Womack	<i>Cottontown, TN</i>

MASTER OF ARCHITECTURE

Michelle R. Barton	<i>Helena, MT</i> Bachelor of Arts in Architecture University of Idaho
Jennifer M. Bradley	<i>Knoxville, TN</i> Bachelor of Arts Maryville College Master of Arts - History University of Tennessee, Knoxville
Brian J. Cutler	<i>Richmond, VA</i> Bachelor of Science in Architecture University of Virginia
James R. Maveety	<i>Arden, NC</i> Bachelor of Arts in Architecture Clemson University
Luke A. Sims	<i>Beaver Dam, KY</i> Bachelor of Science in Engineering and Graphic Design Murray State University
Jacob S. Thomas	<i>Huntsville, AL</i> Bachelor of Arts in English University of the South
Patrick T. Zimmerman	<i>Bethesda, MD</i> Bachelor of Science in Architecture University of Maryland, College Park



School of Architecture

Jennifer Akerman
Brian Ambroziak
Katherine Ambroziak
Ramla Benaissa
Marleen K. Davis
Thomas K. Davis
C.A. Debelius
Mark DeKay
George Dodds
Richard Foster
Diane Fox
L. David Fox
Robert C. French
Duane Grieve
Hansjörg Göritz
Matt Hall
Gregor Kalas
Richard M. Kelso
Scott A. Kinzy
Barbara Klinkhammer
William E. Martella
Paul McCall
John McRae
Tracy Moir-McClean
Dick Overton
J. Stanley Rabun
Max A. Robinson
James Rose
Mark M. Schimmenti
William S. Shell
Ted Shelton
Edgar Stach
Tricia Stuth
Scott Wall

Interior Design Program

Shawn Boles
Alton J. DeLong
Margaret Denney
Melanie Doss
Richard Foster
Jeff Geren
Jon Haas
Josette H. Rabun
Diane Riley
Anne Williams

Supporting Staff

Dimple M. Anderson
Steve Chandler
Thomas E. Davis
Liz K. Hill
Kristi Hintz
Sissy Luqman
Carol Martin
Emily Pace
Shelly Jean Powers
Laurie Roberson
Cindy C. Spangler
Don Swanner
Jeff Wilkinson

university of tennessee
college of architecture and design
1715 volunteer boulevard
knoxville tennessee 37917