

# Portfolio

Matthew Aviña-Quezada

Sutro Bath House  
4

Floaty Folly  
8

Xóchitl Gardens  
10

Encinitas Commune  
16

Corazon de la Raza Mercado  
22

Mobile Cart Series  
26

I Don't Think I Will, But I Have To  
28

SF Pride  
30

# Sutro Bath House

Catherine Herbst - Woodbury University - Spring 2024

Located in San Francisco, on the ruins of the Sutro Baths, this pool house is replaced with a bath house. A monolithic temple in which a person can explore their kinks, desires and sense of self.

Taking influence from Peter Zumthor's Thermal Val along with a combination of ancient bath houses and cruising culture, this bath house becomes a maze. This brutalist-like structure allows for light and the ocean to flood in through the west side openings while keeping the east side in darker atmosphere for a little more privacy. The ground floor resembles a labyrinth, encouraging exploration while bombarding you with sex and nudity. As you move up, floors begin to open up, becoming a space for watching. The top floor is an intimate space, a haven, a place to relax and be with yourself or with a partner(s).

I've reimagined Sutro Baths as queer space that welcomes every sexuality, gender, and identity to allow individuals to discover themselves along with others.

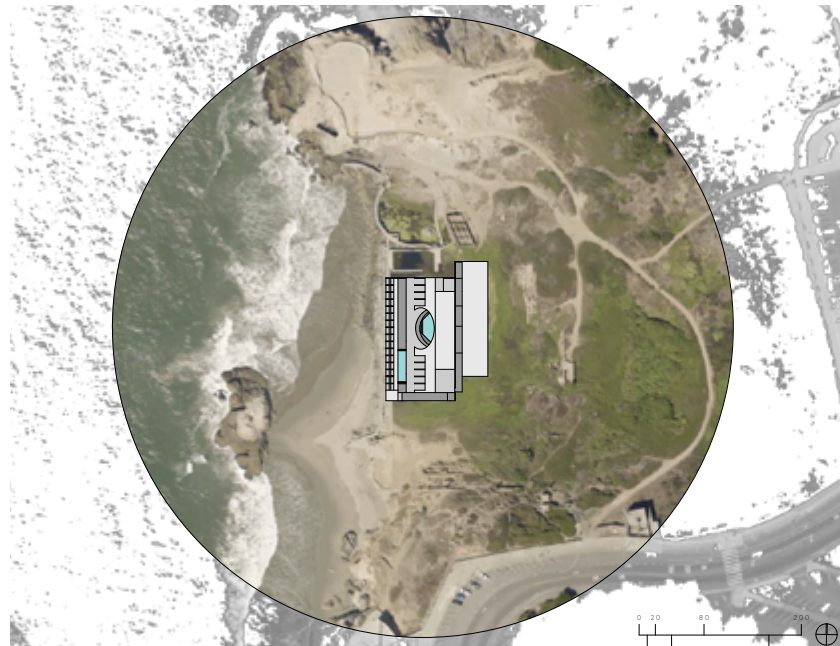
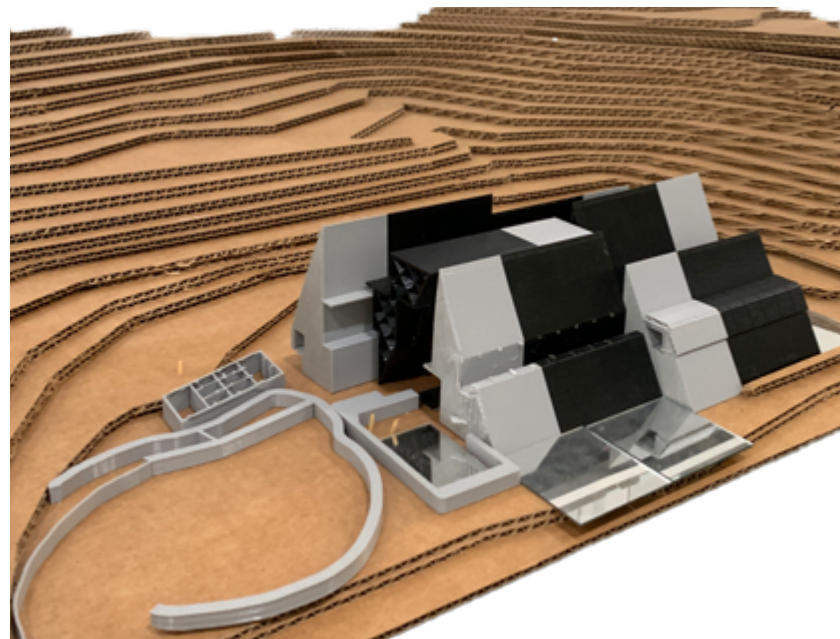

study model + site plan

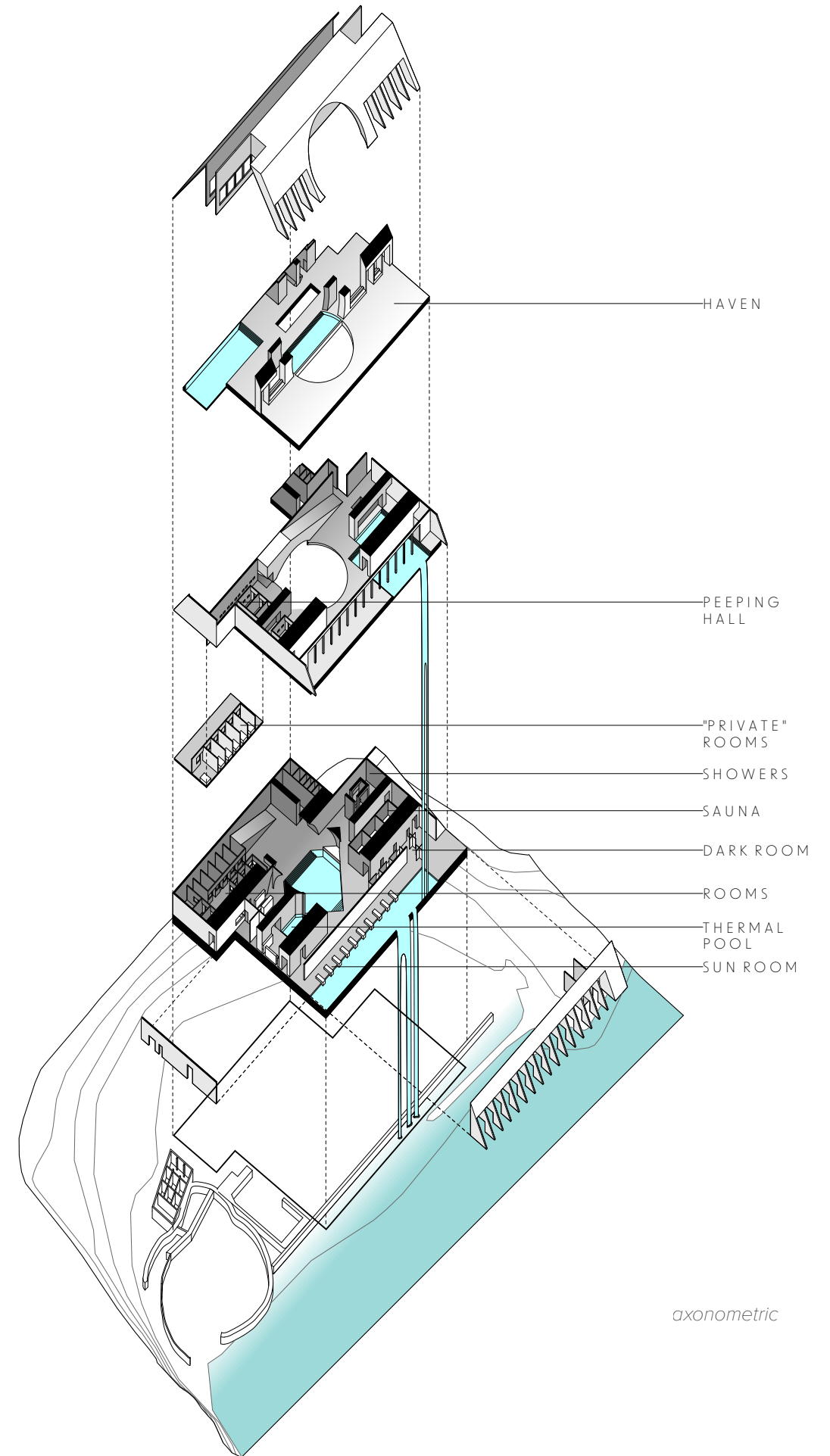

axonometric

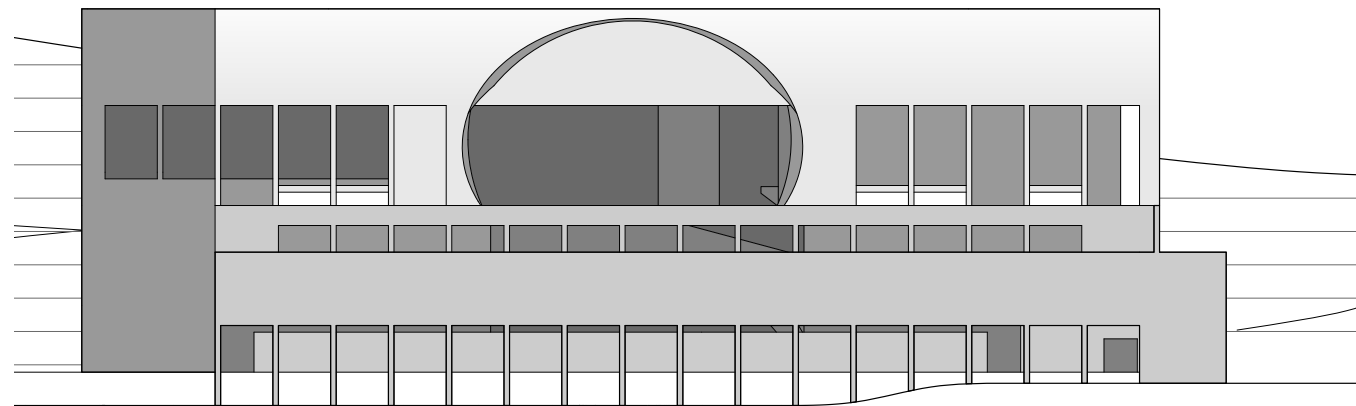

*west elevation*

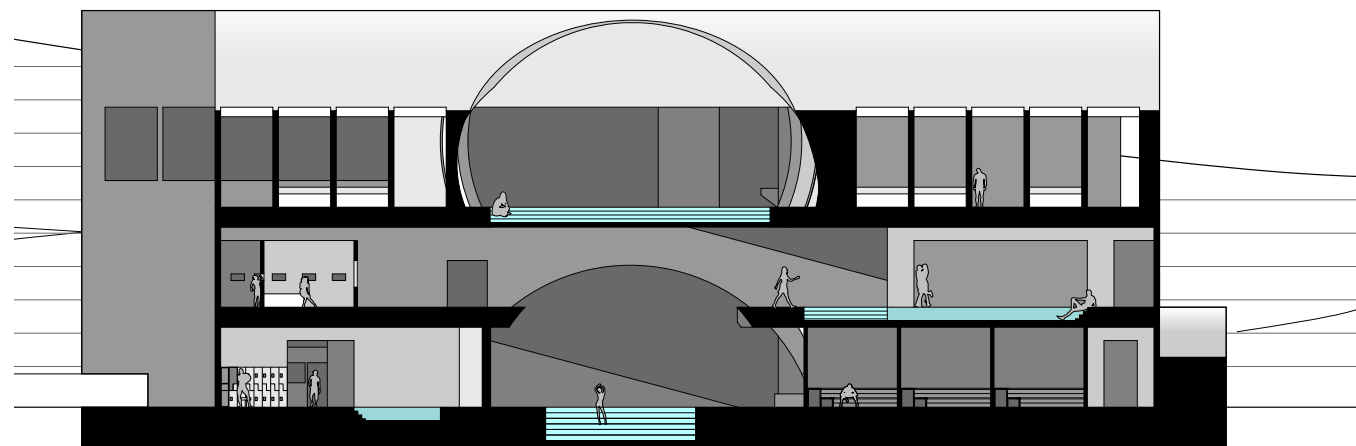

*west section*

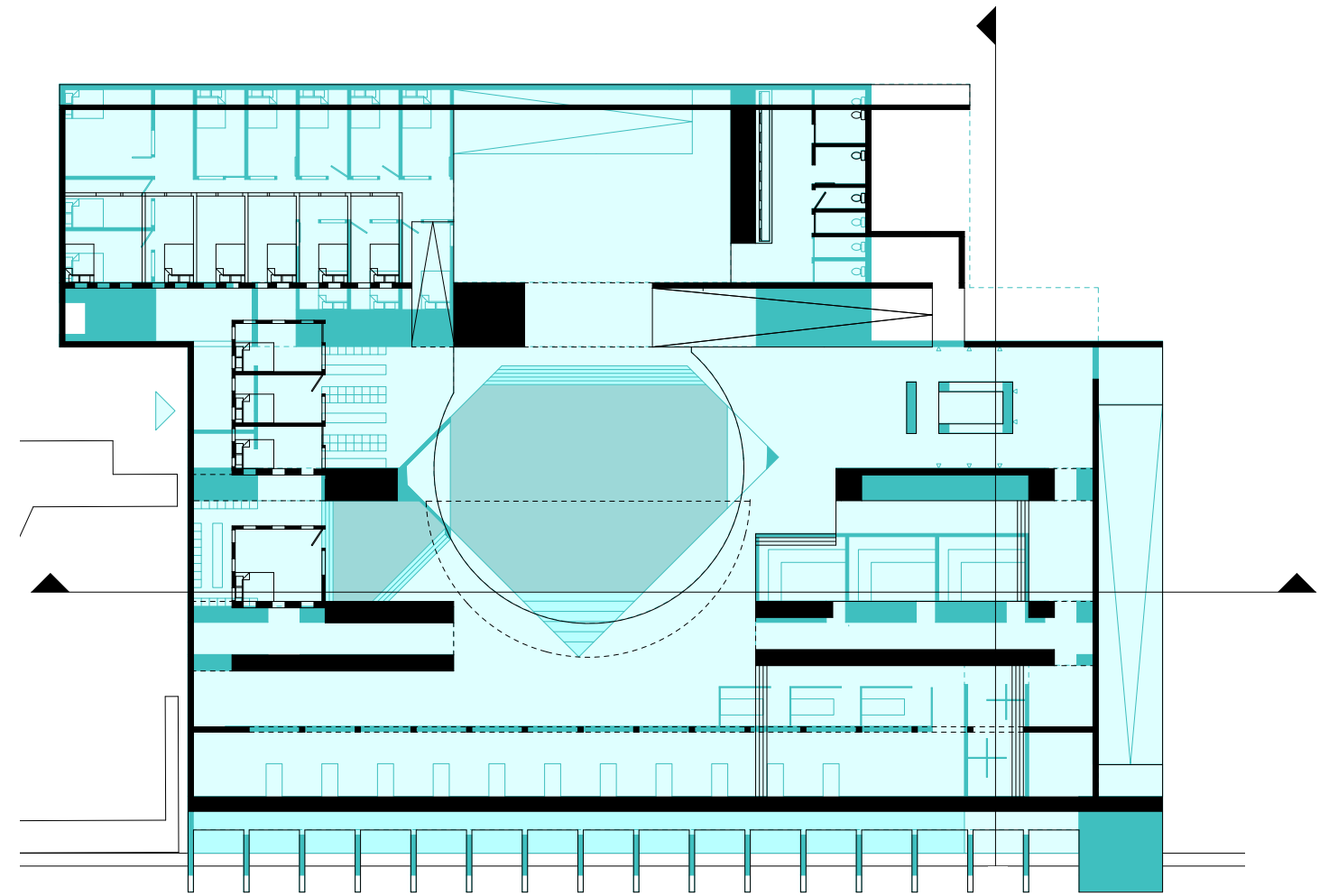

*ground floor plan + second floor plan*



*dark room hallway*

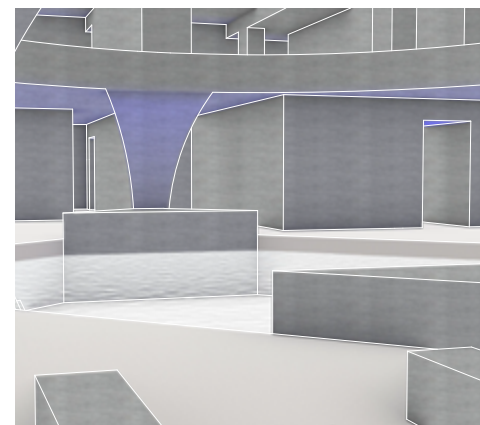

*view from locker room*

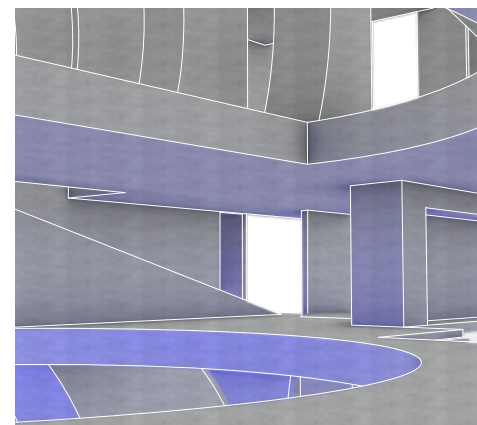

*second floor view*

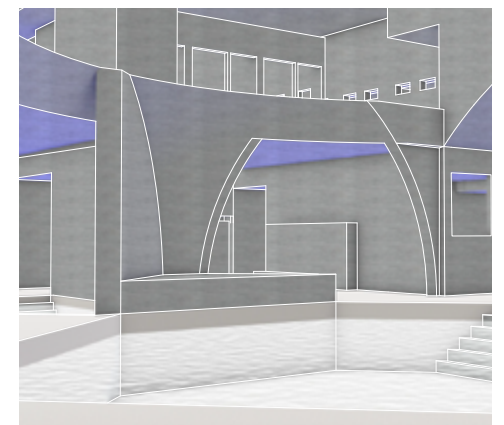

*grand pool*

# Floaty Folly

Hector Perez - Woodbury University - Fall 2023

A design with no plan, but with an explorative process. The prompt was to create an experience without program. I started with wire models that followed the angles formed from hand gestures, then those models were flattened into 2D images and then collaged. These collages left potential, where only the front was resolved. Sketch models were then made to assist, but not complete, the "unseen" sides of the collage, how everything connects and opens into each other. Finally, the sketch model transforms into the final folly.

A large, open, pyramid like structure that plays upon illusion. This folly invites and entices to explore the structure, rewarding them with a grand view at the very top. There was no rhyme or reason to this process at first, but was highly rewarded through creativity and ambition

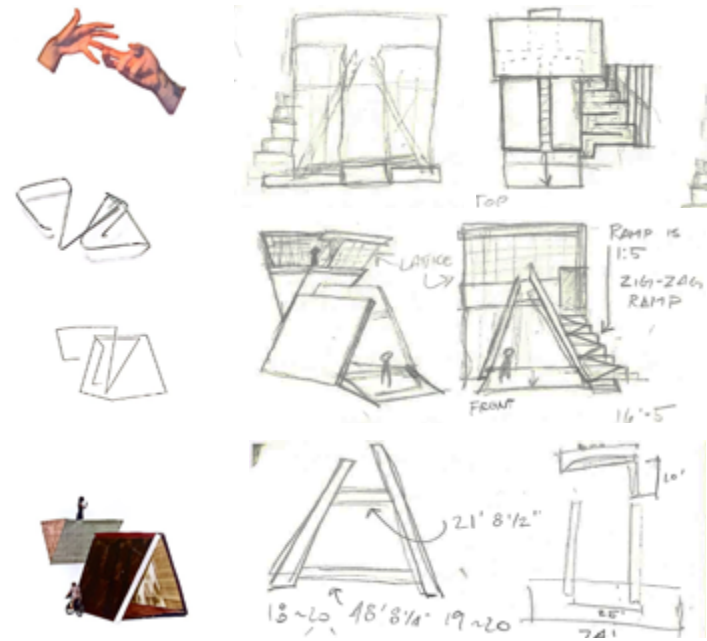

concept sketches + selected sketch model



model exterior + interiors

# Xóchitl Gardens

Hector Perez - Woodbury University - Spring 2023

A transitional housing project for queer youths who've run away from home or have been kicked out due to sexuality or gender identity. I wanted to create a sanctuary space for the young LGBTQ+ community due to my own experiences. No one should bear the constant questioning of acceptance and fear alone.

Xóchitl Gardens is located in Barrio Logan, right next progressive and open-minded businesses and had the potential to be something that is more than just a housing shelter, I wanted to create a space of equality, acceptance and tolerance.

I designed from the inside out, using sketch models to estimate the size of each program, expanding from that minimum. Shapes were formed with function in mind, using walls on the southern side of the site for sound abatement. The middle of the site contains the majority of programs and divides the site to ensure privacy and anonymity when needed.



concept sketches + diagram of site

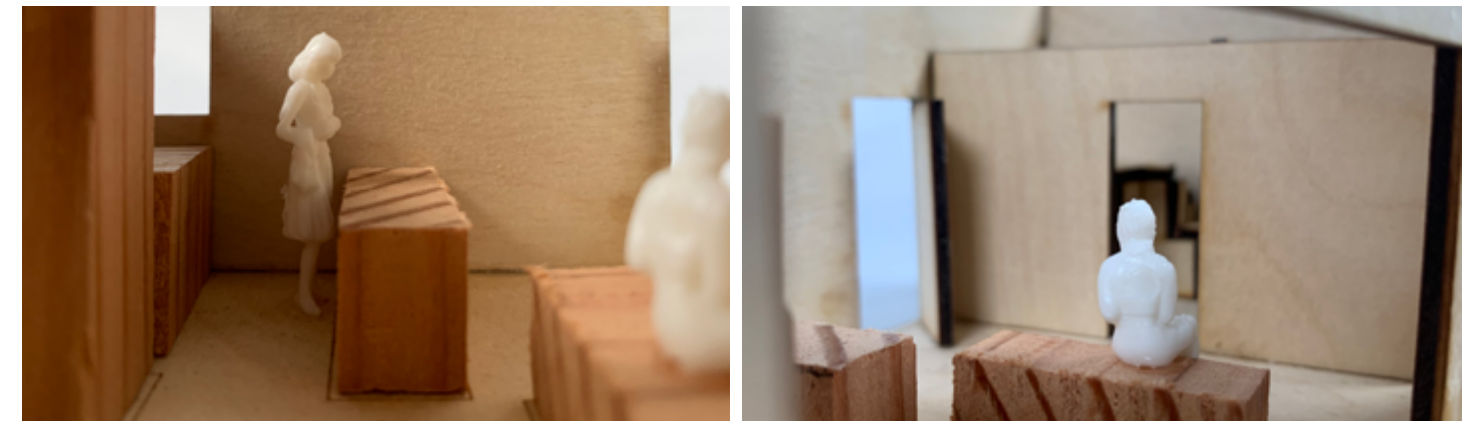

physical model + unit interiors

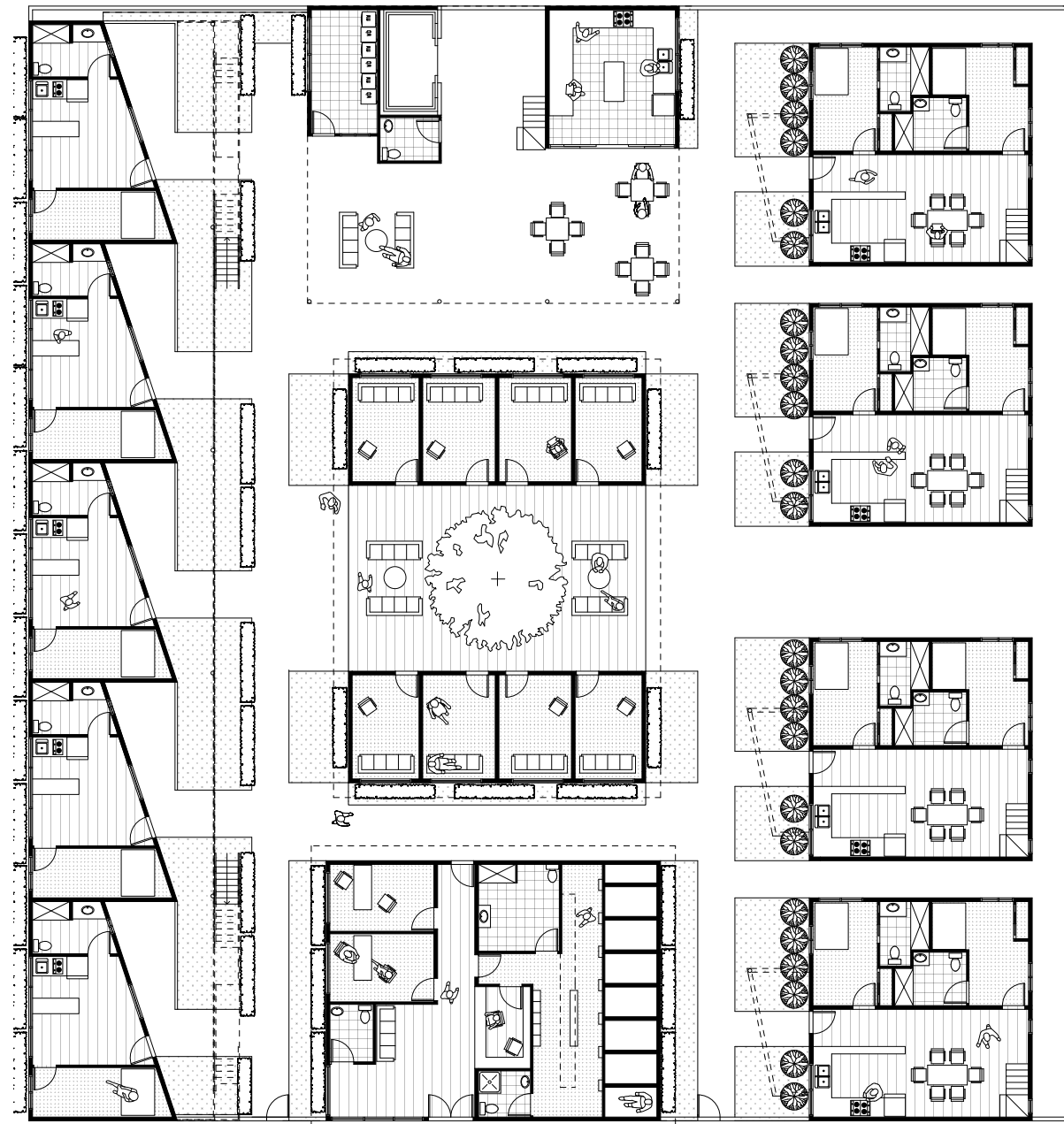

ground plan

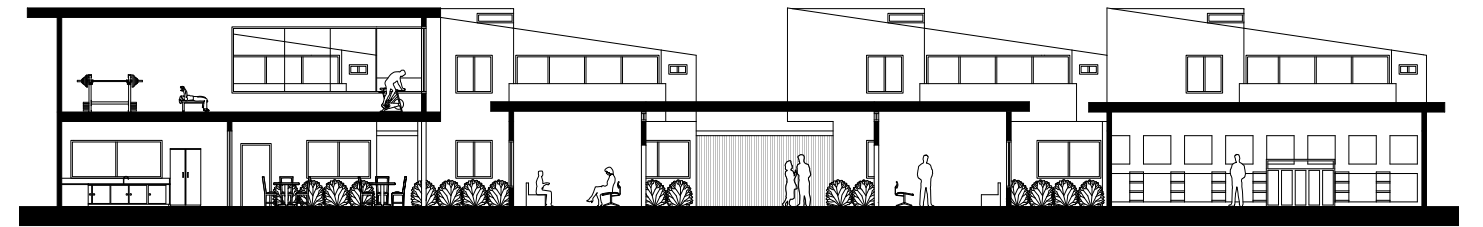

Section A



Section B

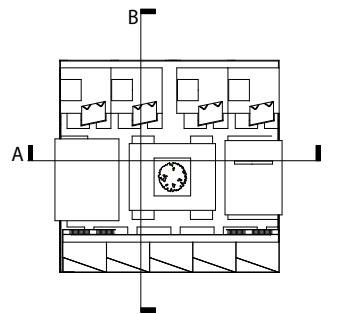

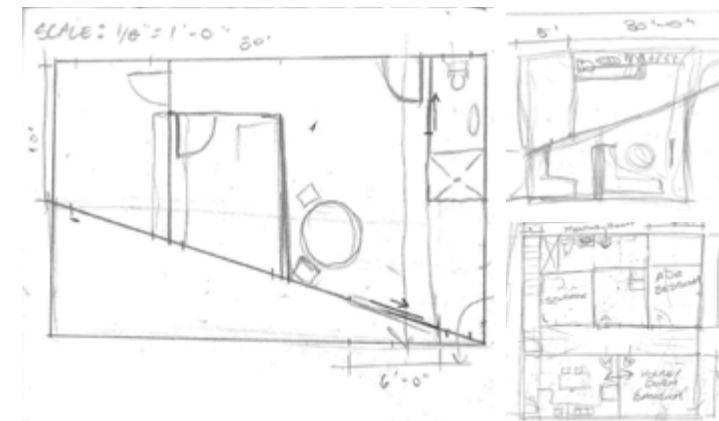

exterior views of final model

apartment type units

dorm housing type units

# Encinitas Commune

Catherine Herbst - Woodbury University - Spring 2023

Repurposing an elementary school, redefining entertainment and community, through exploration. The site is divided and pieced together, encouraging inhabitants to interact with amongst each other. Housing shelters, History educates, Food and Drink entertainments and Art finds.

This project strengthens and promotes community. A large site leaves room for opportunity for many programs. My inspiration came from exploring monastery typologies and pieced them together to create a maze, just to fill the lot. Eventually, the collage of monasteries became the entrances, exits, arcades, spaces in between where programs came to life.

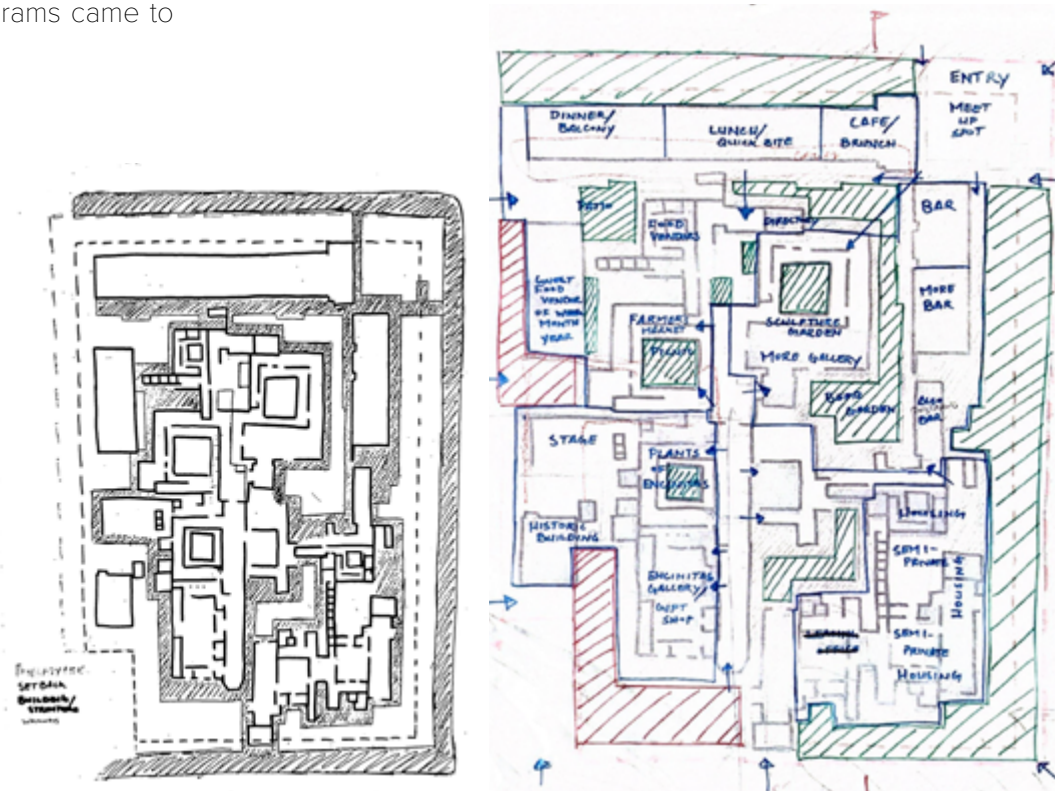
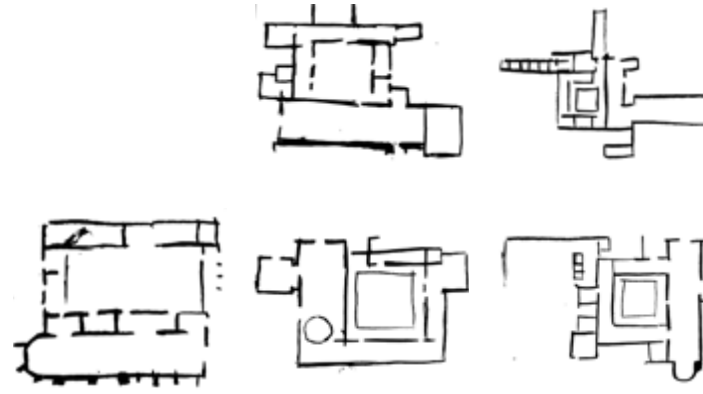

monastery sketches + site sketch



exterior renders with point cloud

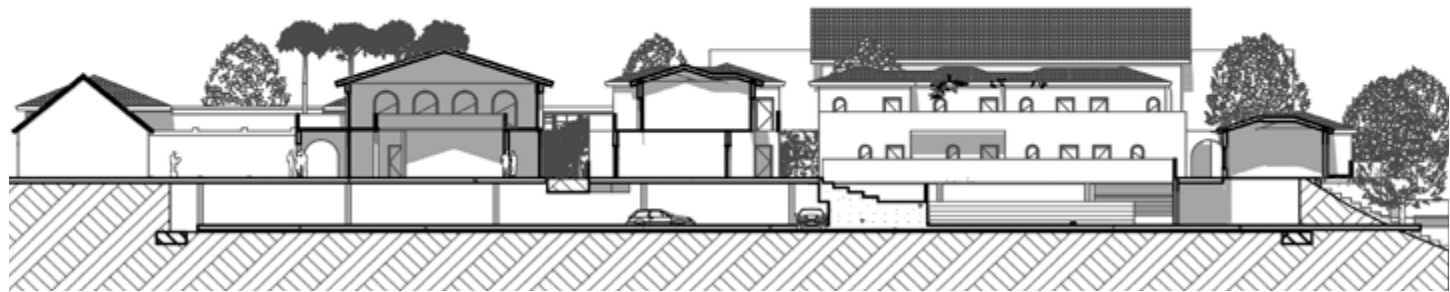

*south section*

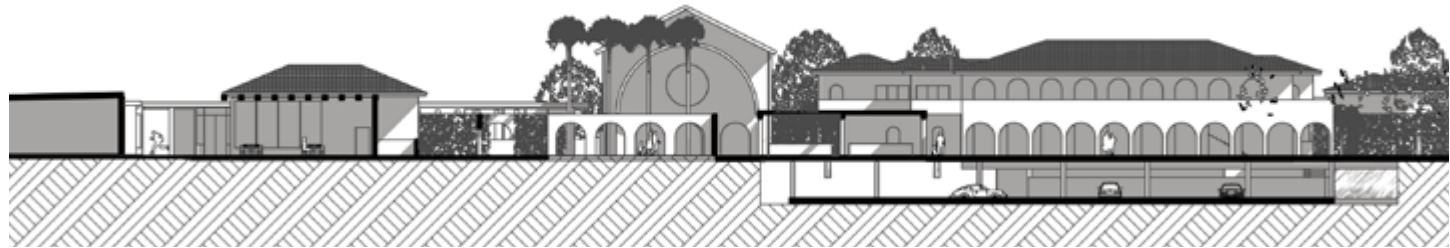

*west section*

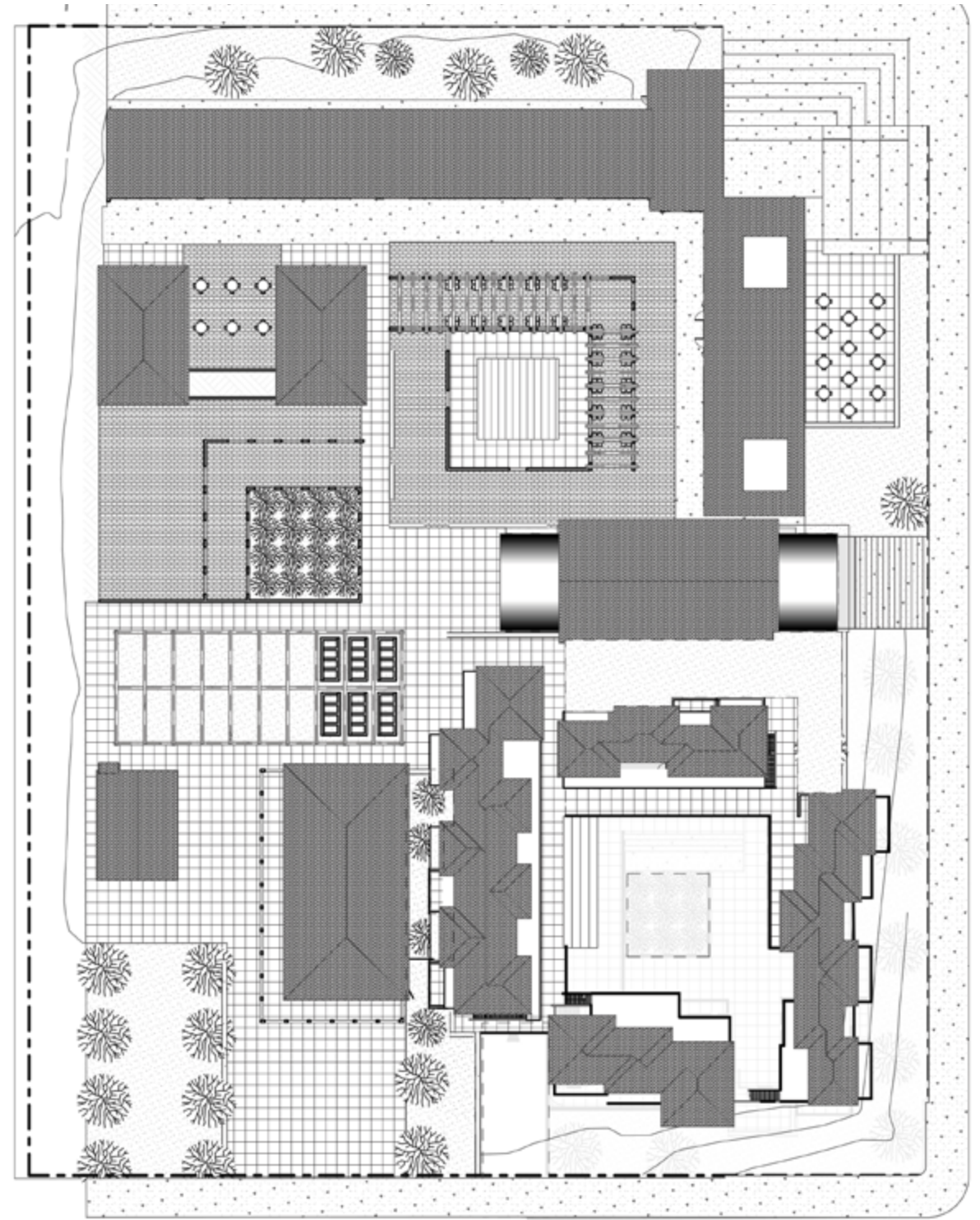

*site plan*

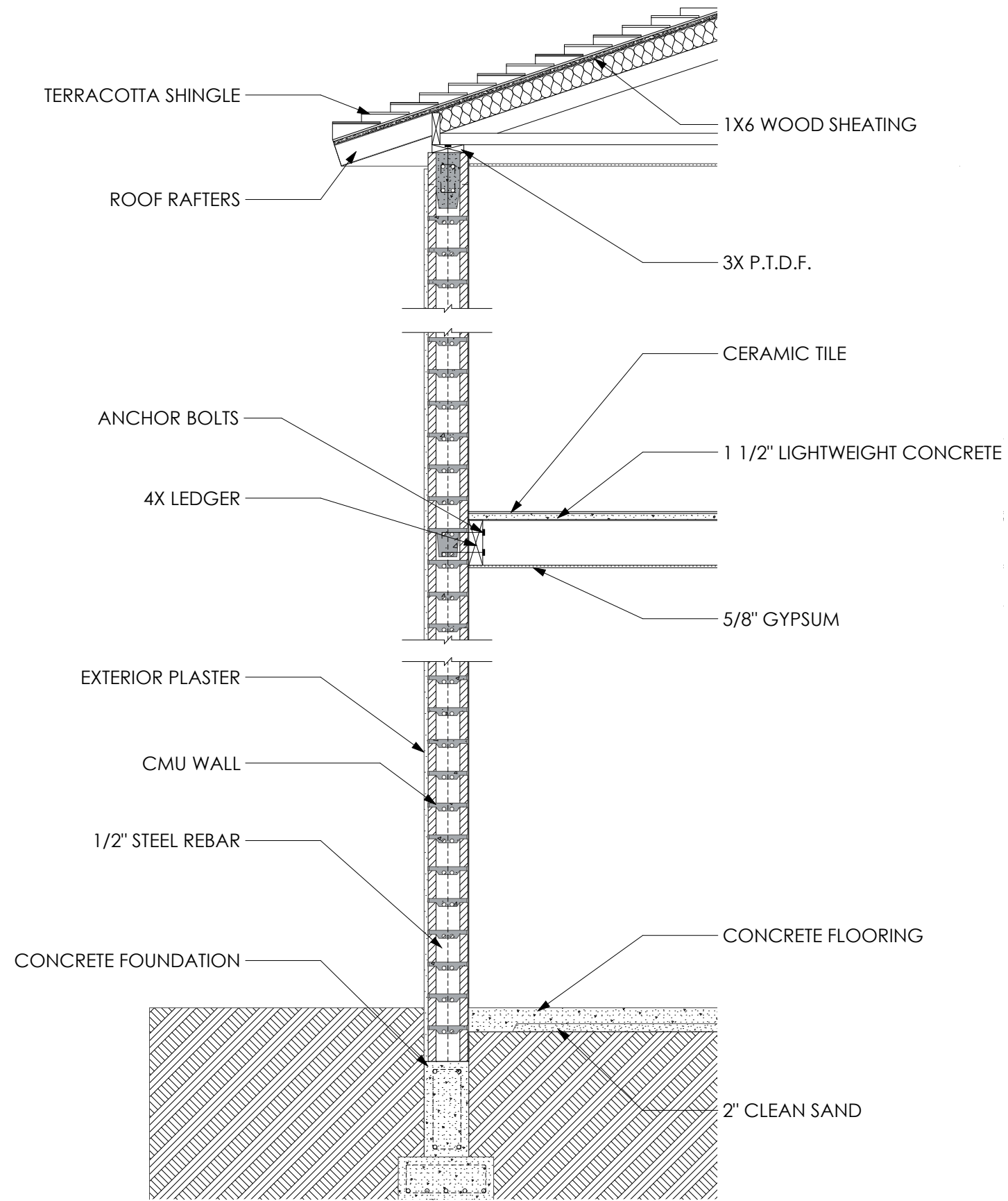

wall section

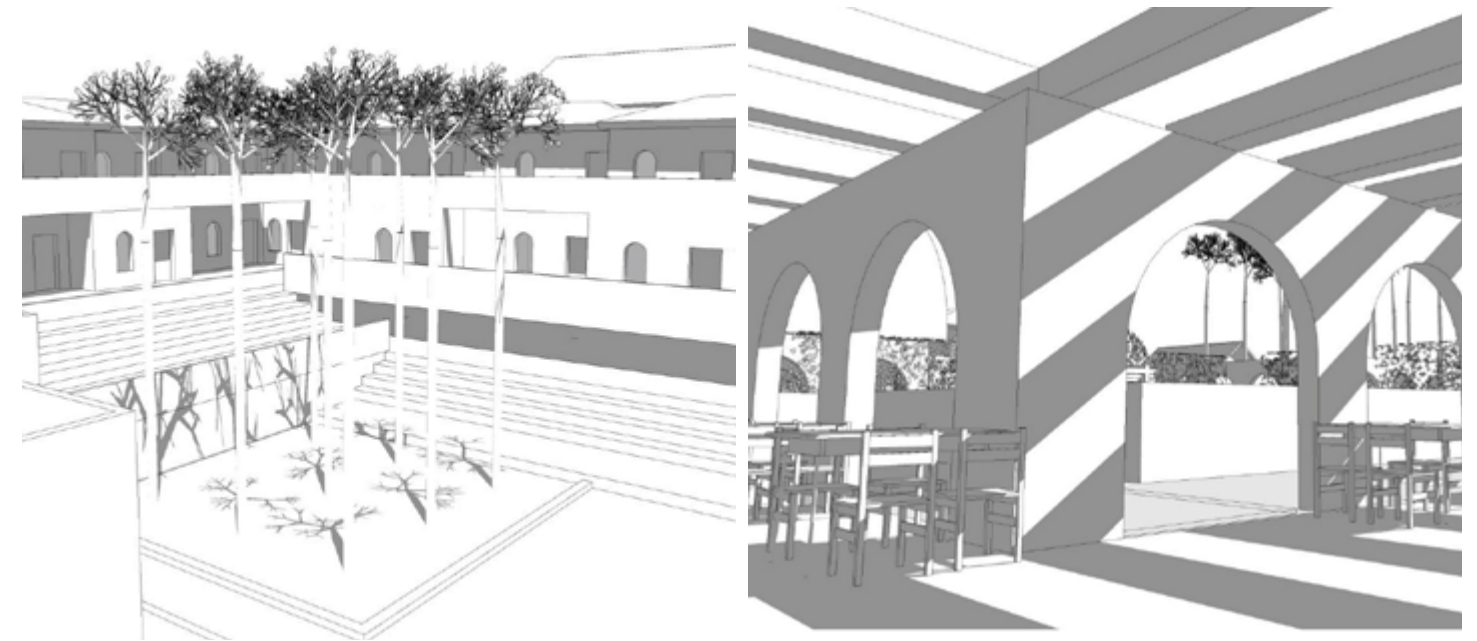

exterior renders

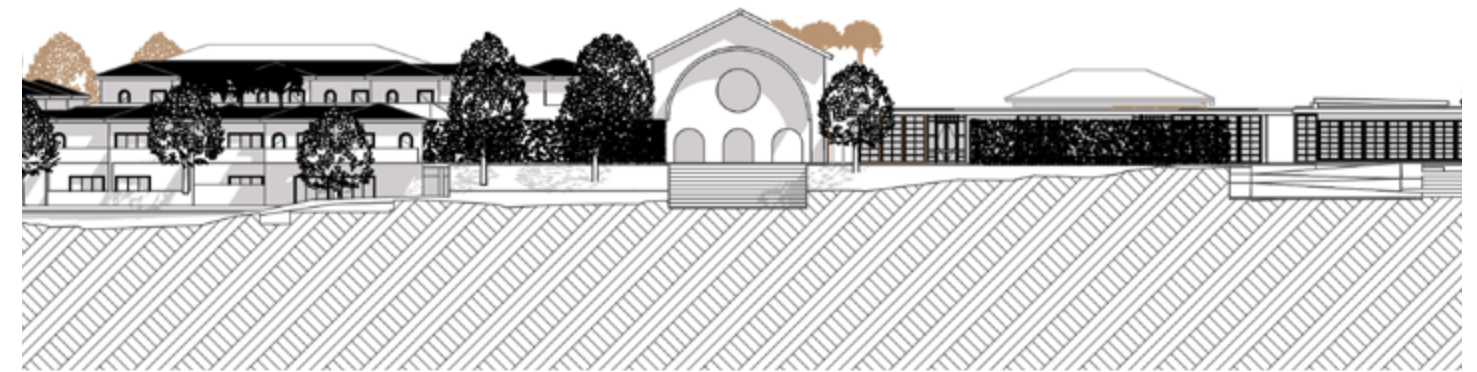

east elevation

# Corazon de la Raza Mercado

Hector Perez - Woodbury University - Spring 2022

Taking influence from Kazuyo Sejima's Art Science Department in Osaka, Japan and discoveries from the Mobile Market, I attempted to solve a difficult shaped site with a grid and post and beam system to create a central market in Barrio Logan. The columns fall either at the intersections or within the lines of the grid, taking structure into heavy consideration.

My goal was to create a multi-purpose space that represents more than just a market. I wanted a central space where the people of Barrio Logan can call their own, to express themselves within the Barrio Logan community.

There are spaces for vendors, a stage for performances and an art studio/gallery for artists. This project was more than just solving a difficult shaped site. This program had to fit into its surroundings, the availability of public transport, the ease of traveling from downtown, and apartments that hold families.

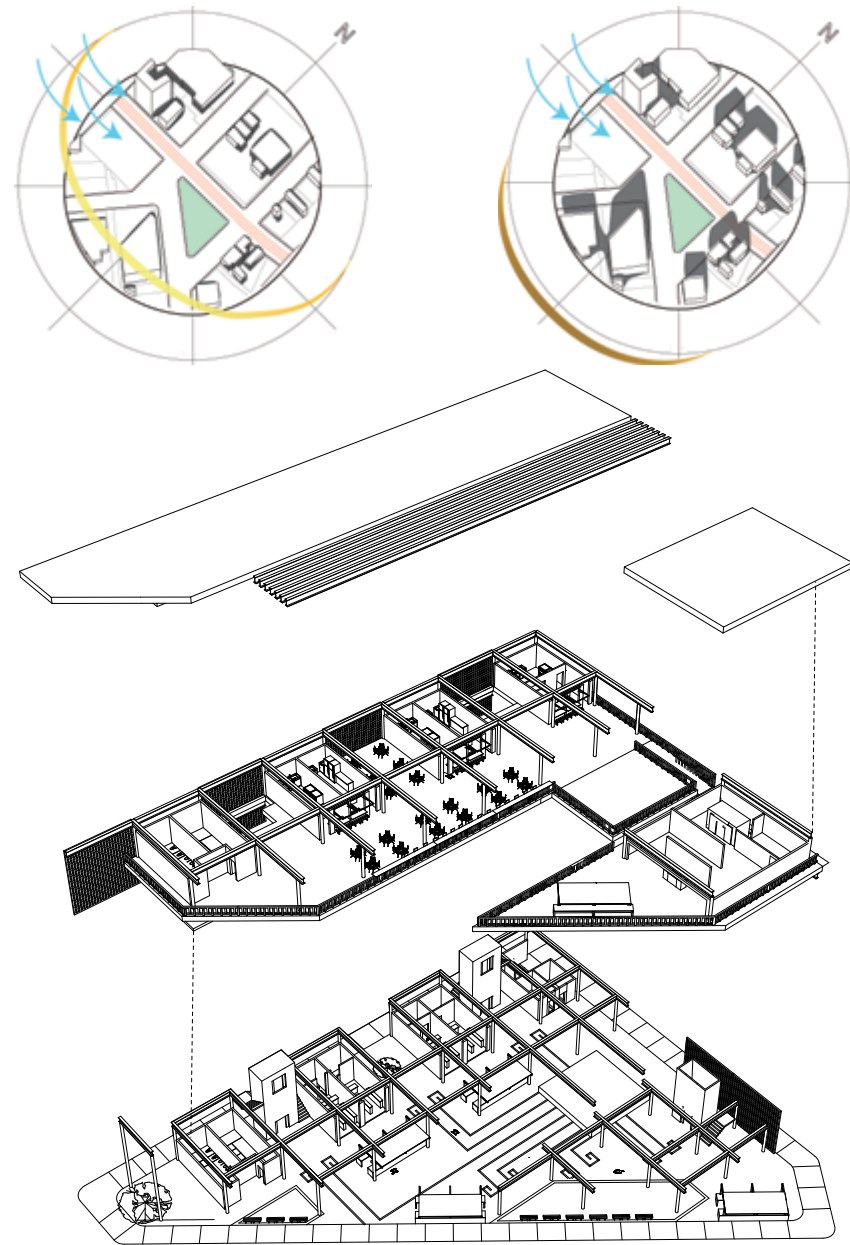

summer/winter solar diagram + axonometric

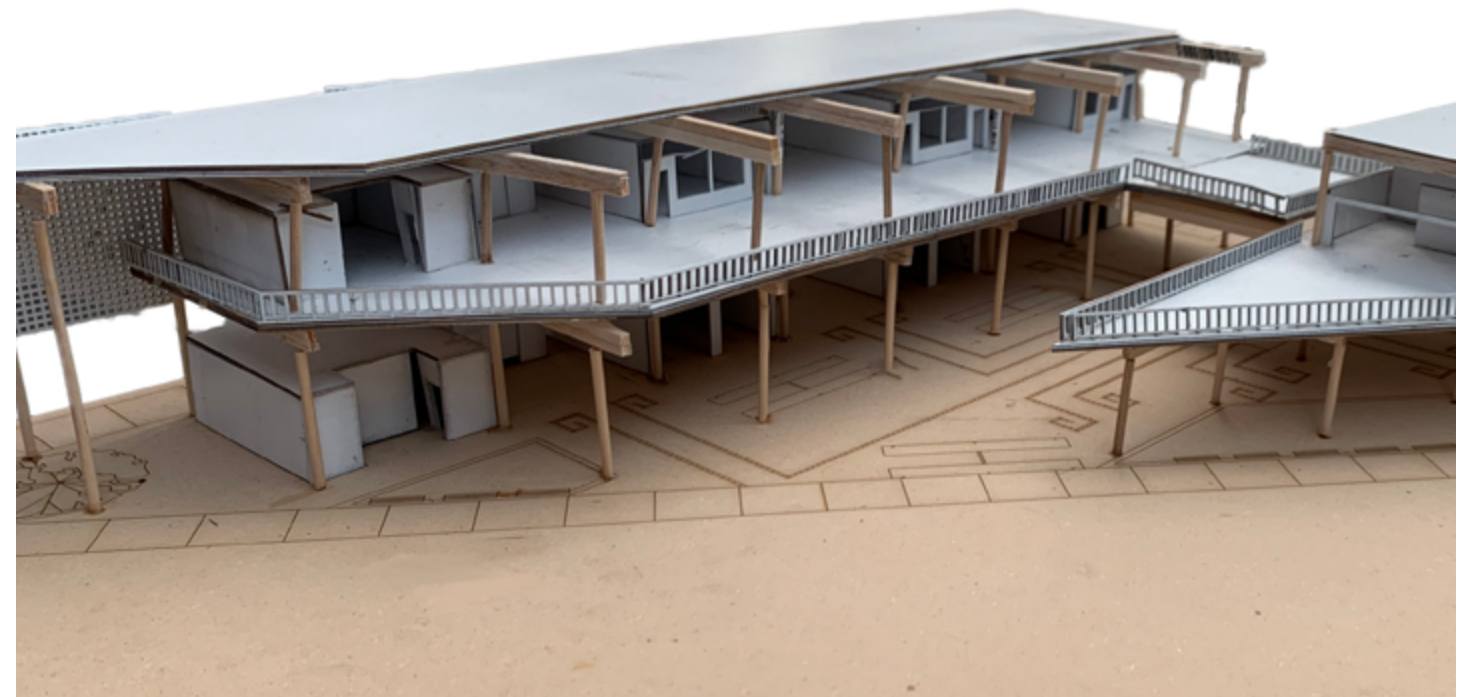
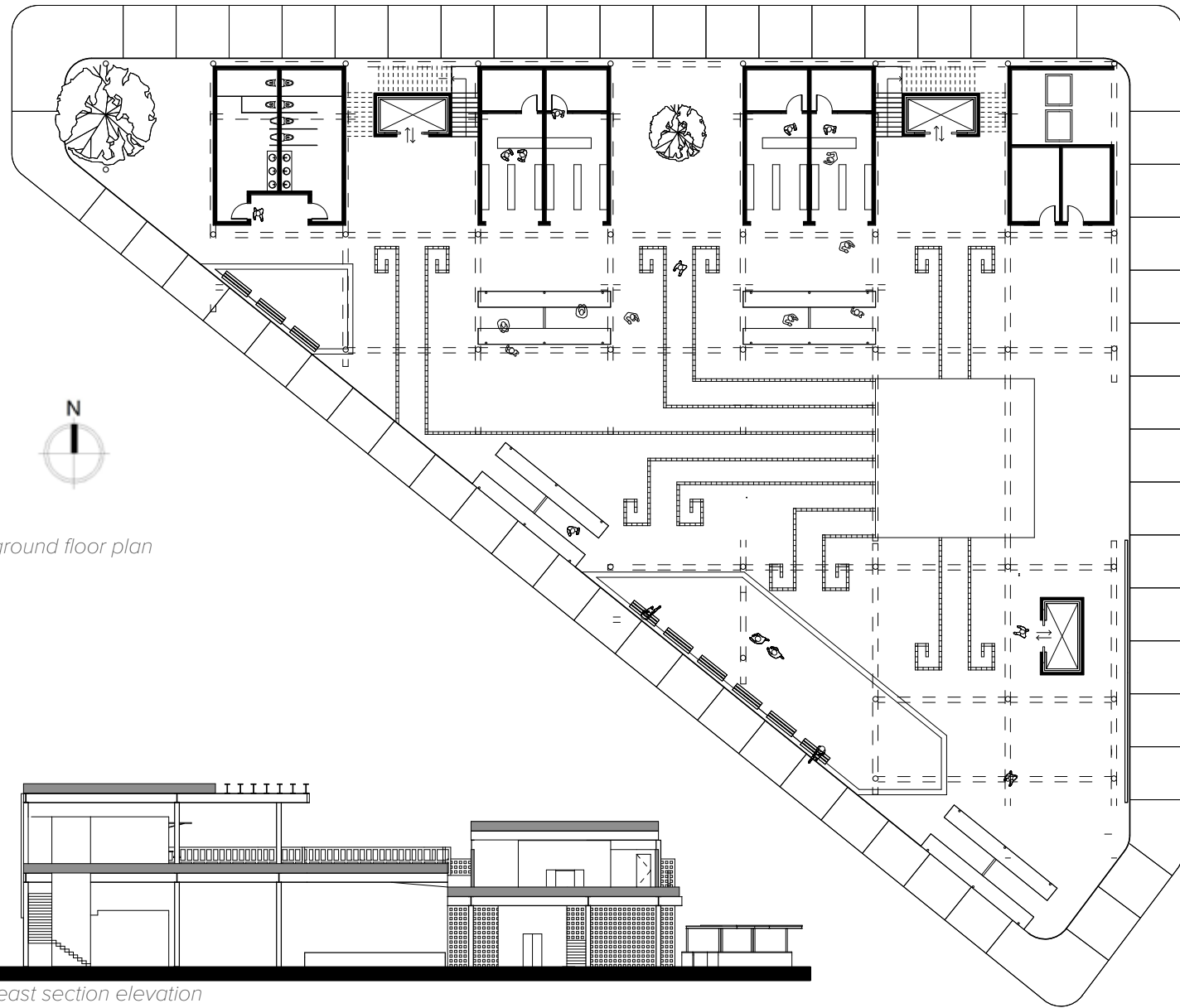
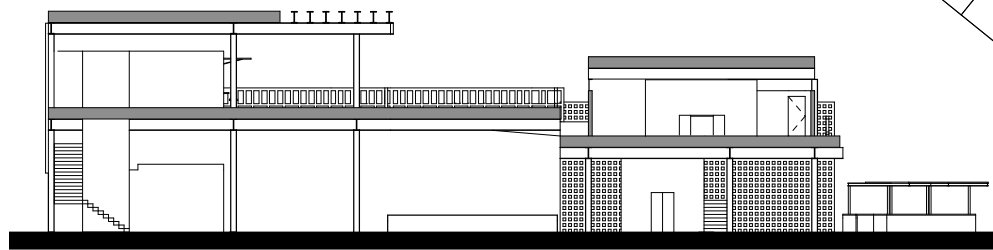

diagram + final model



ground floor plan



east section elevation

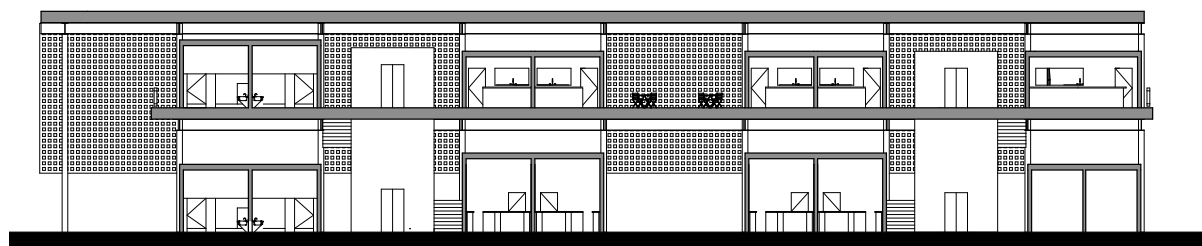

south section elevation

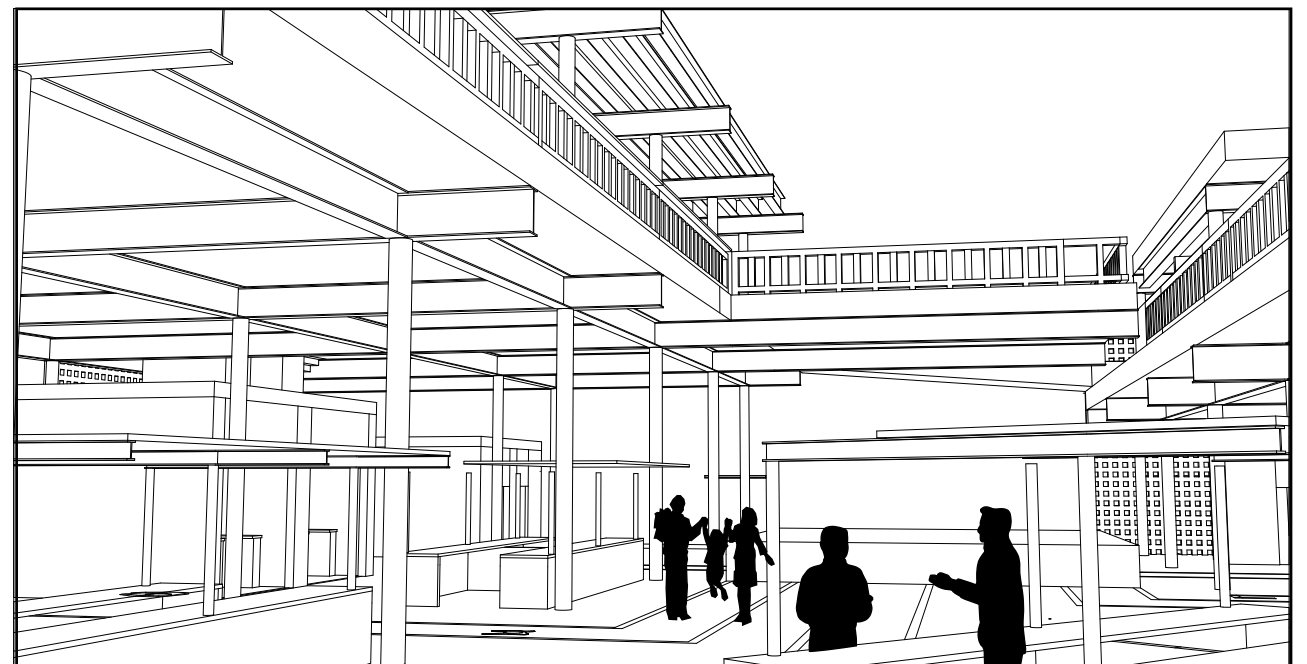
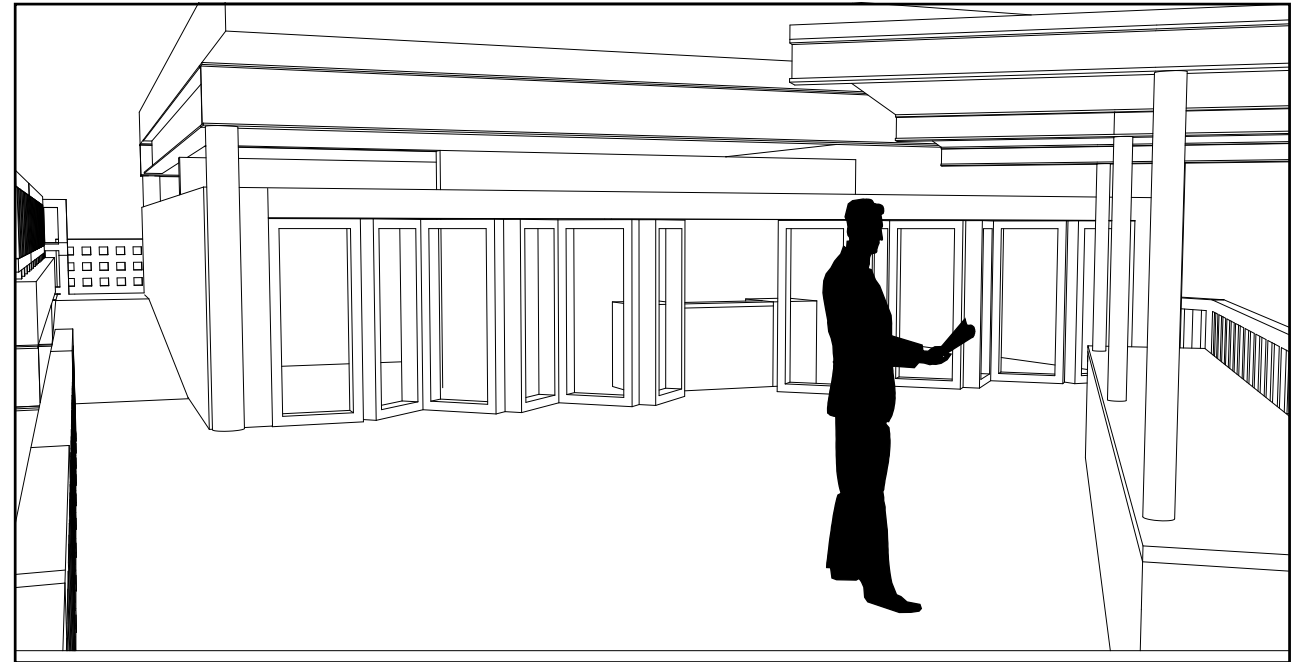

exterior renders

# Mobile Cart Series

Hector Perez - Woodbury University - Spring 2022 + 2023

Quick exercises to provide a program without a definite site. I took scrap materials and pieced them to create sketch models of potential, functioning carts.

On the Jugo-Go is a mobile market where the service provides juice and other drinks to patrons. While Centi(stam)pede is the second rendition in the mobile cart series. I explored Theo Jensen's Strandbeasts; taking note in how the physics of parts works and the reality of being built on a 1:1 scale.



On The Jugo-Go: sketch model, render, + axonometric

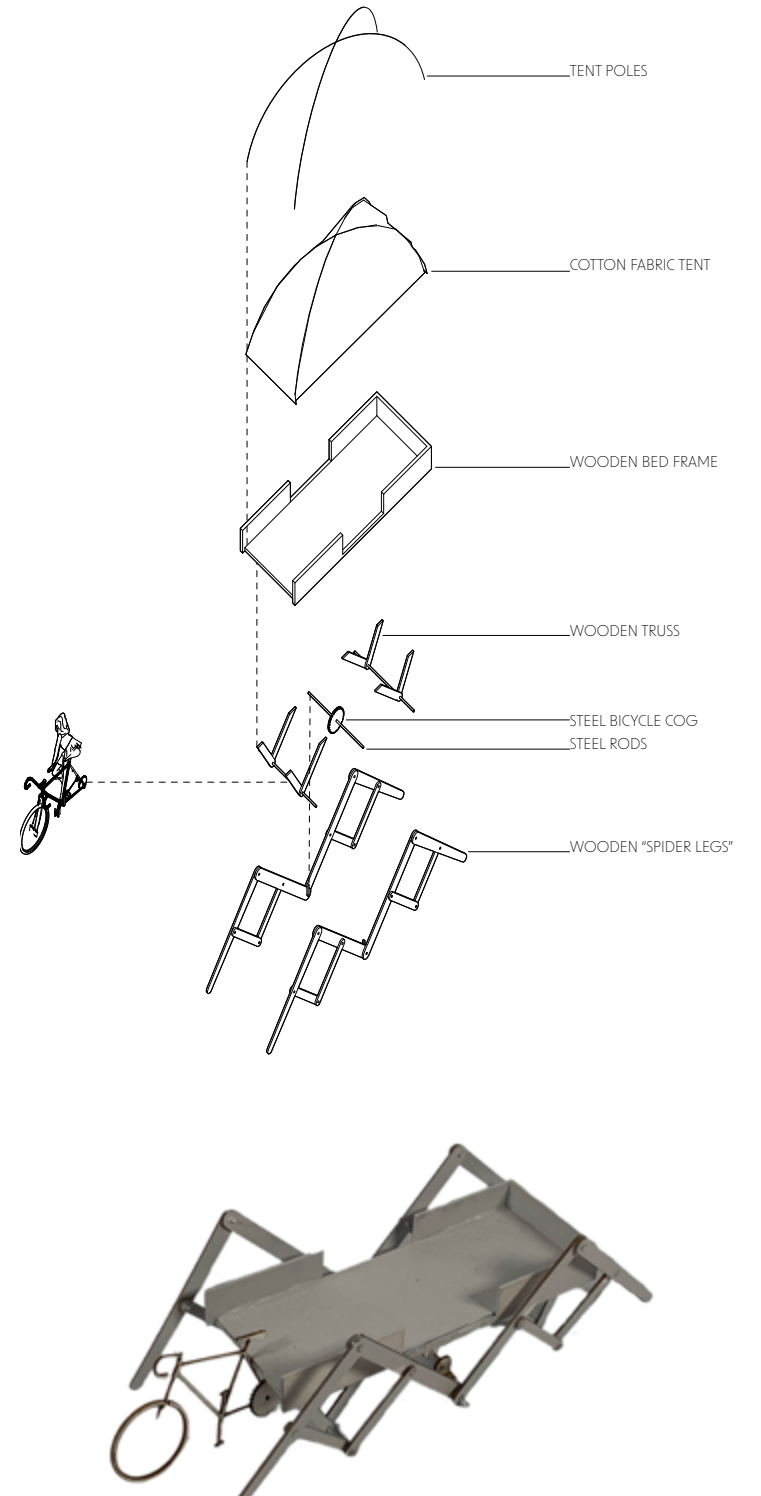
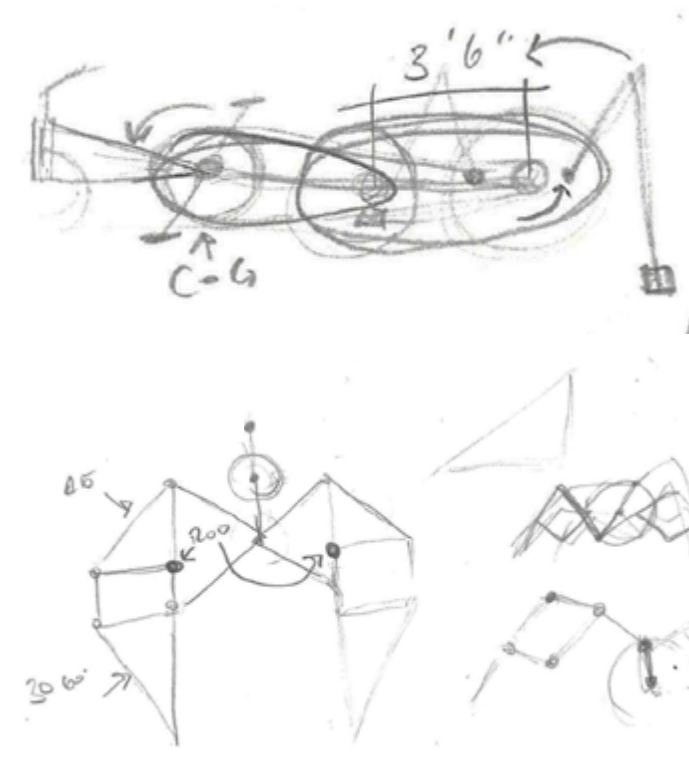
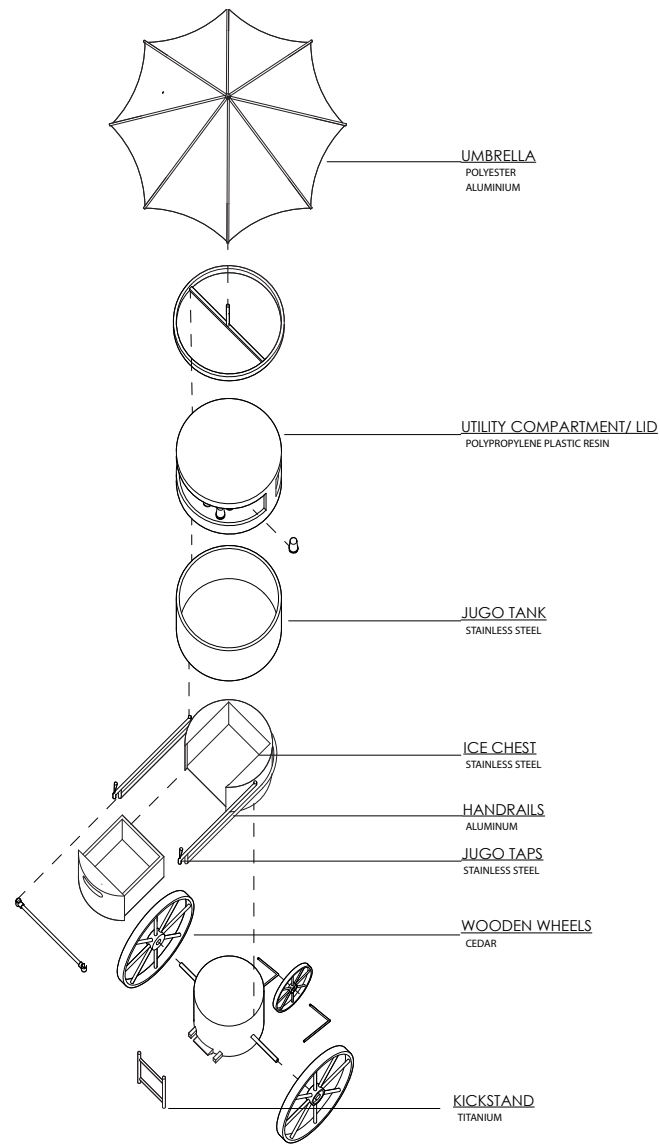

centi(stam)pede: concept sketches, axonometric + study model

# I Don't Think I Will, But I Have To

Hector Perez - Woodbury University - Fall 2023

Complementing *Floaty Folly*, this project started with built work, instead of starting from the abstract. I took pictures of Frida Kahlo and Diego Rivera's home in Mexico City, making sure to capture its connections to the ground, sky and body of the structure. From my images, I created a collage, an object that seems to float in space, then recreated that collaged object to a line drawing in Rhino. Finally, I filled in the line drawing using ink, pens, scrap, magazine and created the piece *I Don't Think I Will, But I Have To*.

It closely resembles my mind a personality, constant explosions of anxiety, snide remarks and comments, a humor that is loud. Creative freedom is the forefront of this piece, in which I would initially disregard my instructor's advice, but would then follow, hence the name of the piece.

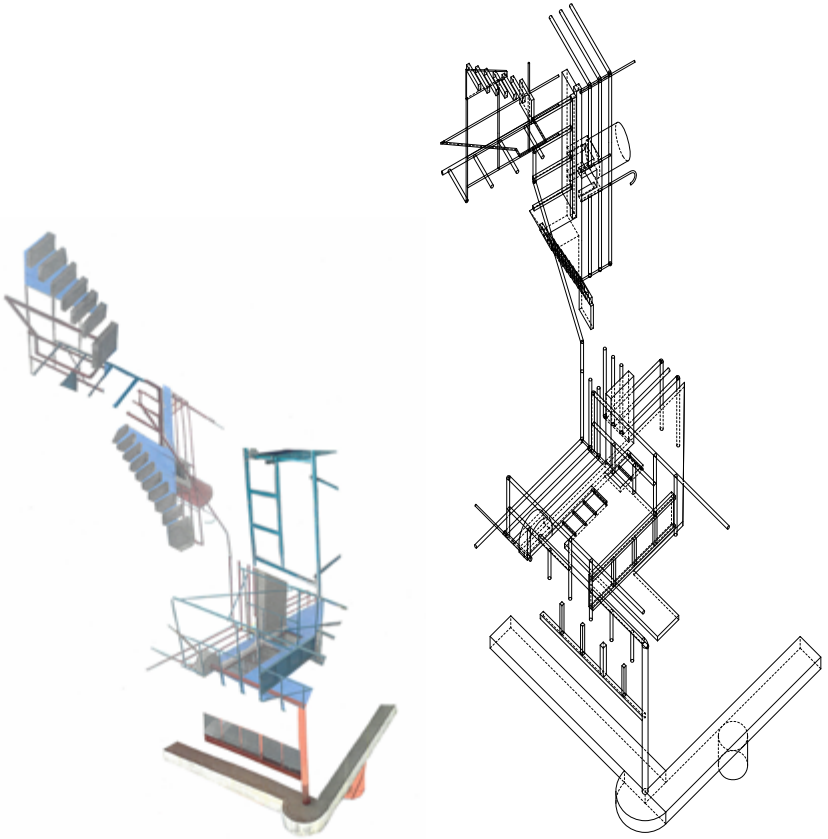

photos of Museo Casa Estudio, collage of selected elements + line drawing

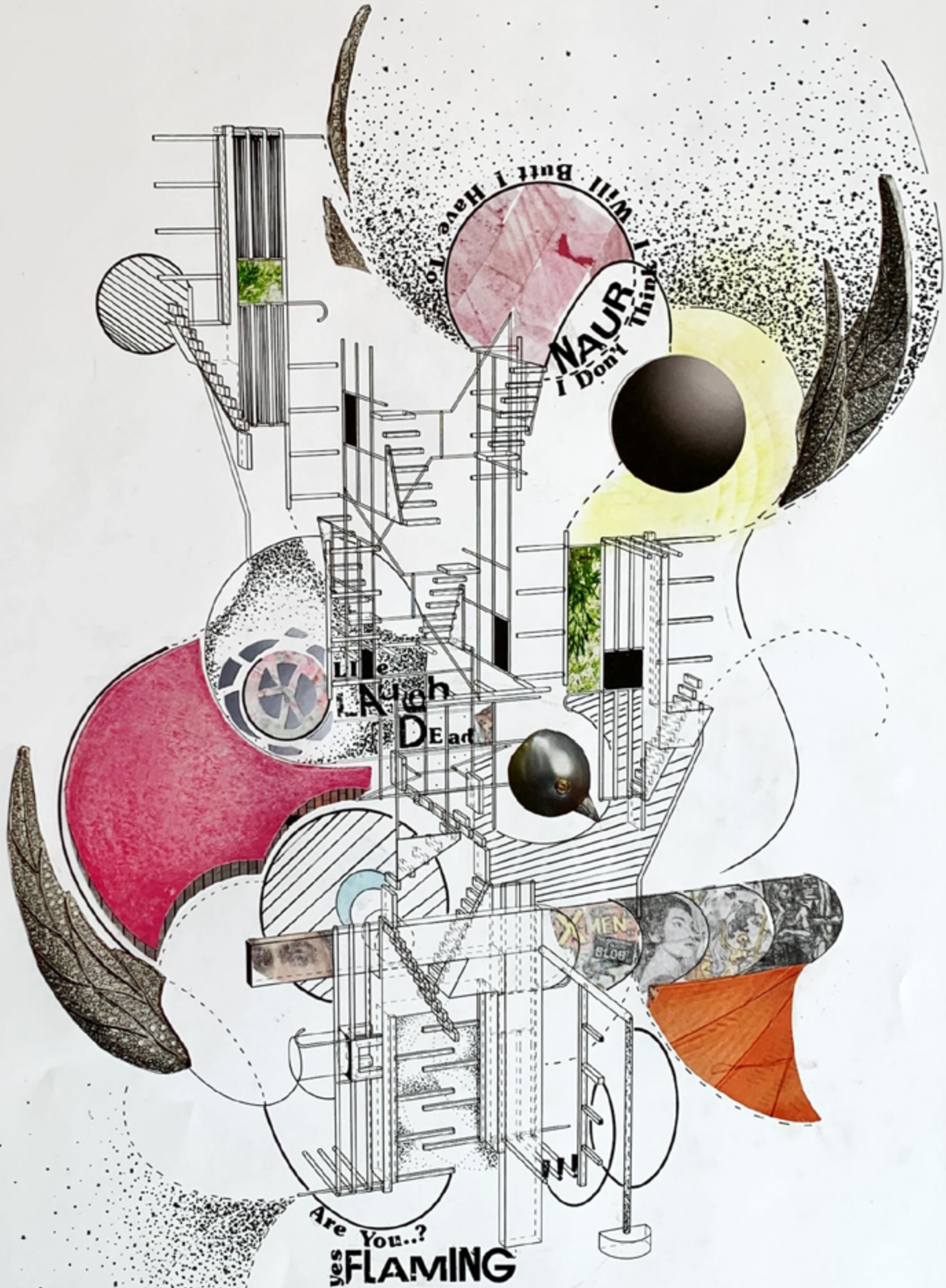

# SF Pride

Stephen Klippenstein - Fullerton College - Spring 2021

Creating an event poster, that is personal and sort of a first step of putting myself in my work. I created this poster during quarantine, it is an event that I had missed the most was San Francisco Pride. It's a joyous event in which I celebrated myself and my community, and thinking back to these memorable events is what I needed during the storm that was the COVID pandemic. I often like to put a little bit of my own personality into projects, whether it be my sexuality or ethnicity, in an attempt to break the stereotype of who and what a queer person looks like and to, hopefully, be a beacon and inspiration for others.

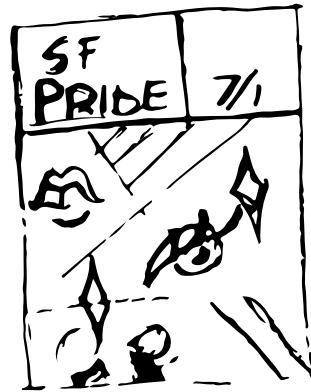
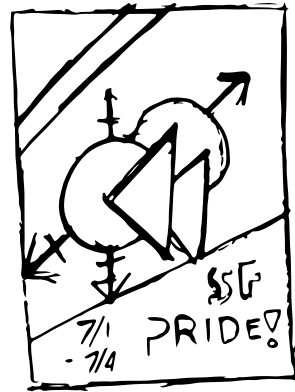

concept sketches + inspiration board

