

PORTFOLIO



Lan Wei
Architectural Design
Email: lanwei027@gmail.com



HILLSIDE OF THE ARTS

CULTURAL COMMUNICATION CENTER

The Hillside of the Arts project will establish a Cultural Communication Center on Torrão's scenic hillside in Portugal. This project aims to revitalize the area by transforming an old olive oil farm into an art center celebrating local ceramic traditions. The center will feature ceramics workshops and a food court, fostering cultural connections between China and Portugal, and offering long-term and short-term programs for artists and travelers.



1. Site View Analysis



2. New Axis insertion



3. New Structure Reinforce



4. Detail Construction

- New Axis Insertion -

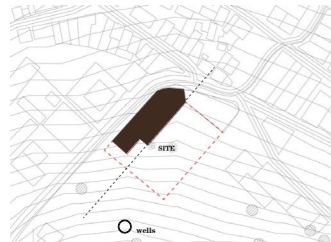

Step1. Old factory Axis

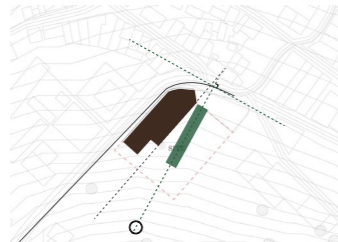

Step2 new axis — a vertical line perpendicular to the road through the center of the well circle

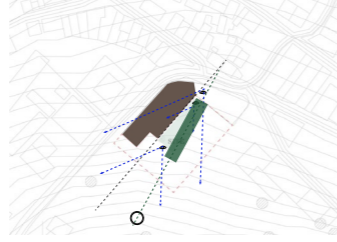

Step3. new volume considering the views

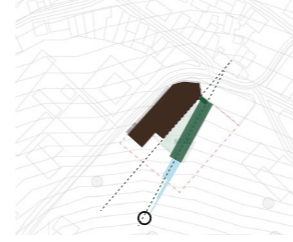

Step4. Create connections to the old well

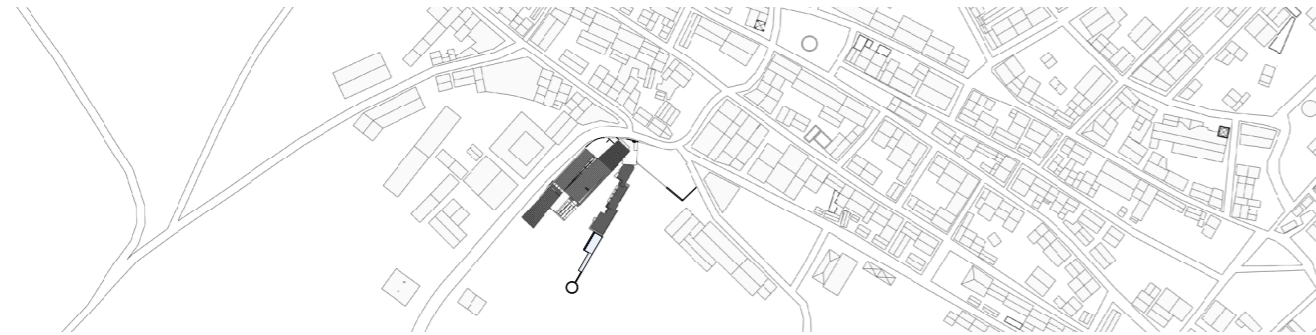

- Structure & Material -

-  Steel Plate
-  Wood Truss
-  Wood Columns 200*200mm
-  Tree Trunk 300*300mm

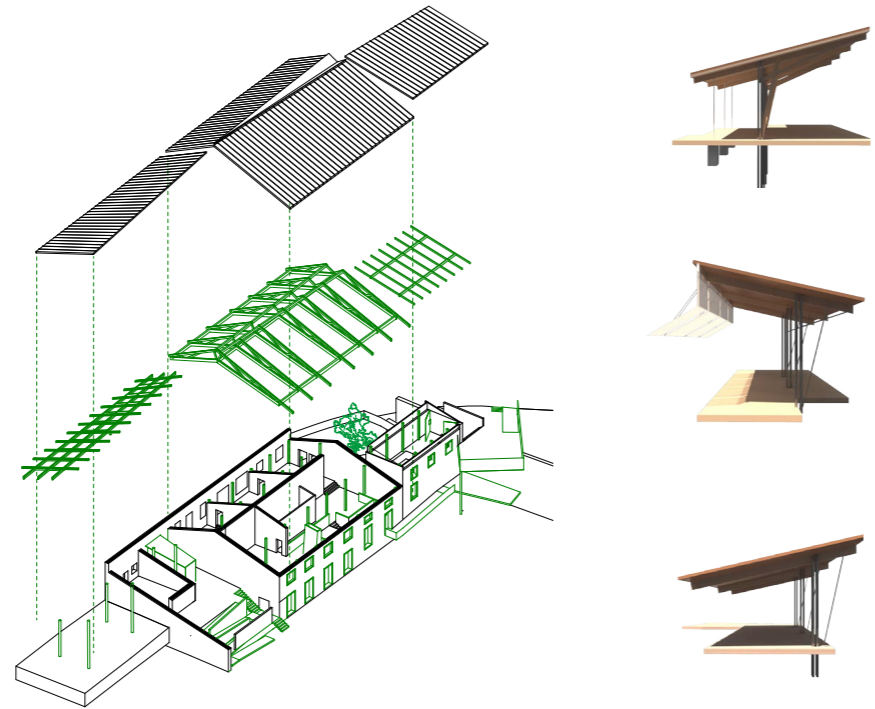

- Section -





Free Studio



Gallery



Private Studio

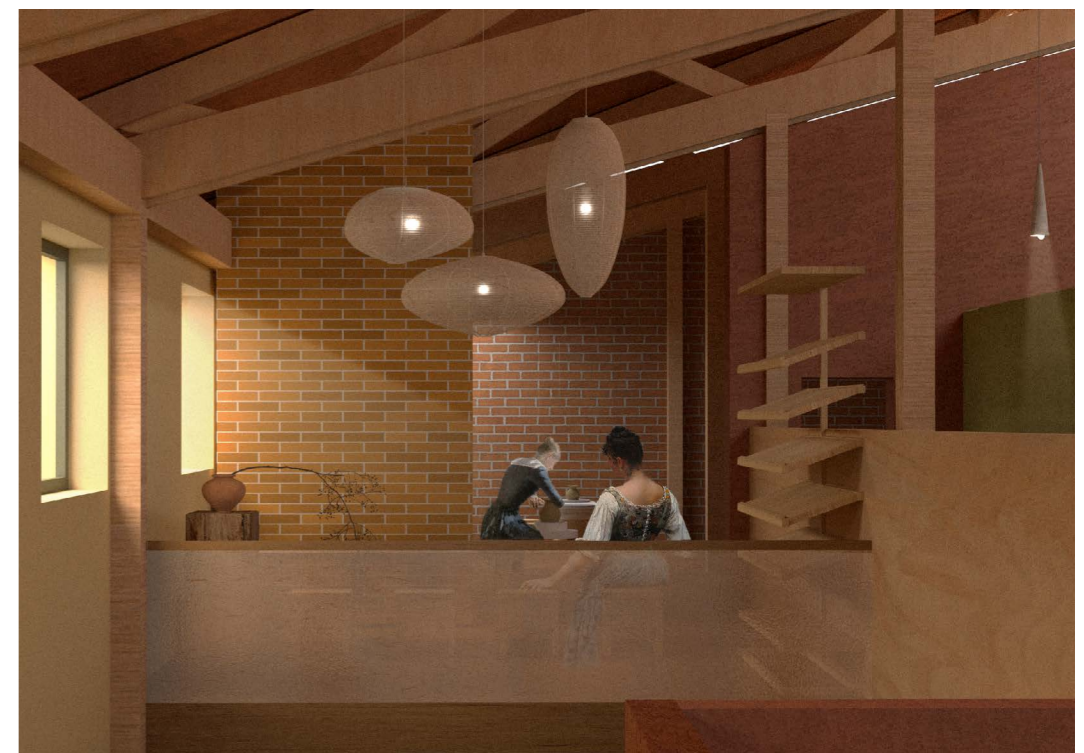







STABLE

A HOME FOR THE HORSES IN YUNNAN

Yunnan horses (yoho) played an important role in transporting goods along the ancient tea-horse route. Nowadays, the horses have been replaced by modern transport. Many local horse caravans choose to sell their horses to make a living, resulting in a drastic decline in the number of Yoho. The design of this project is to build a shelter with the horse (yohu) as the main body, hoping to protect this species through the form of architecture, and at the same time let the culture and spirit of the Dian horse be inherited.



Exterior Rendering

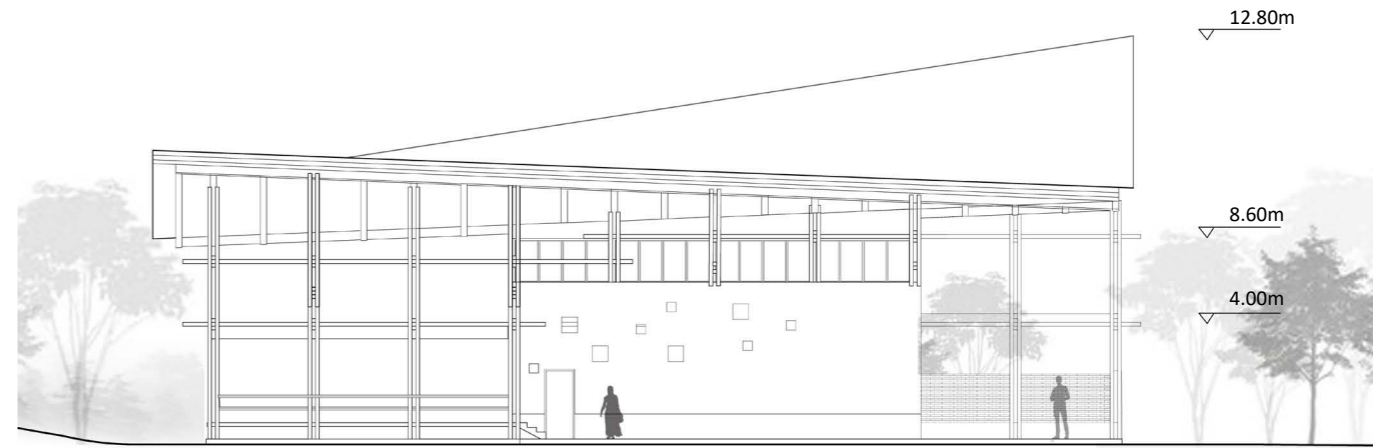

West Elevation

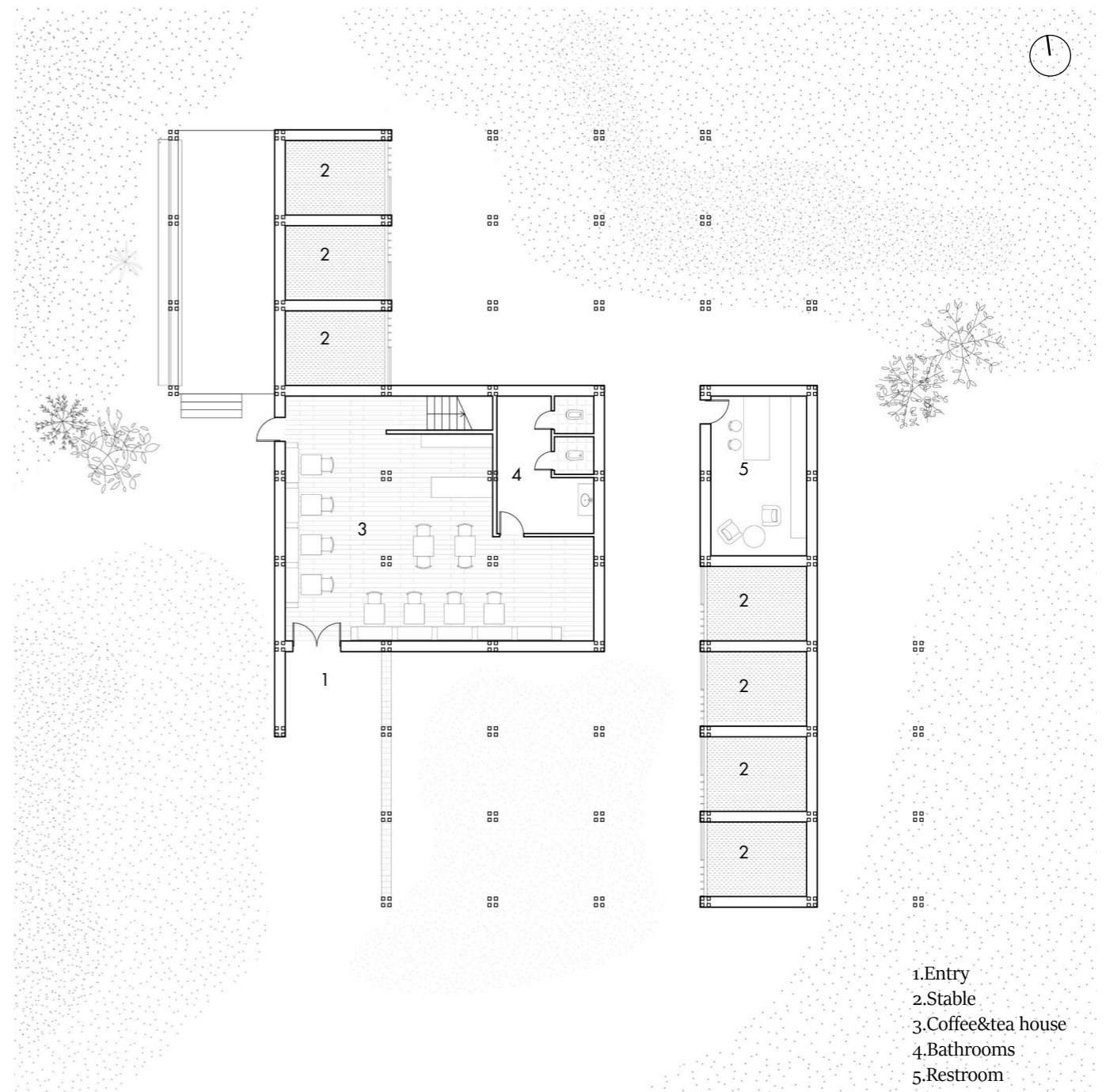

Ground floor plan

- 1. Entry
- 2. Stable
- 3. Coffee&tea house
- 4. Bathrooms
- 5. Restroom

0 1 2 3 4 5



Interior Rendering

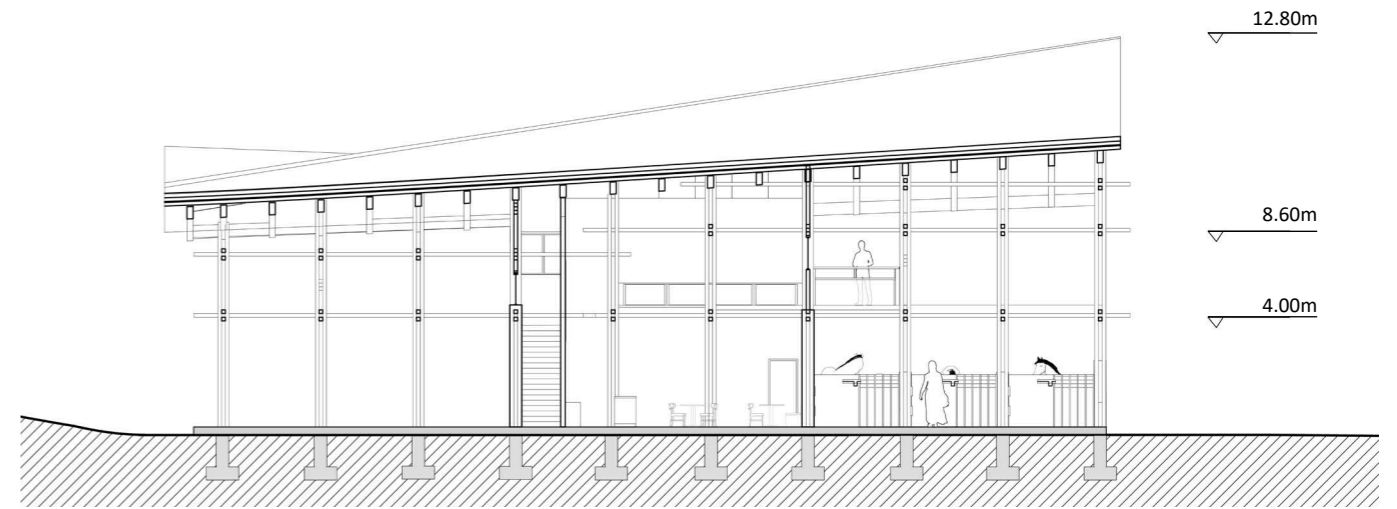

Section A-A'

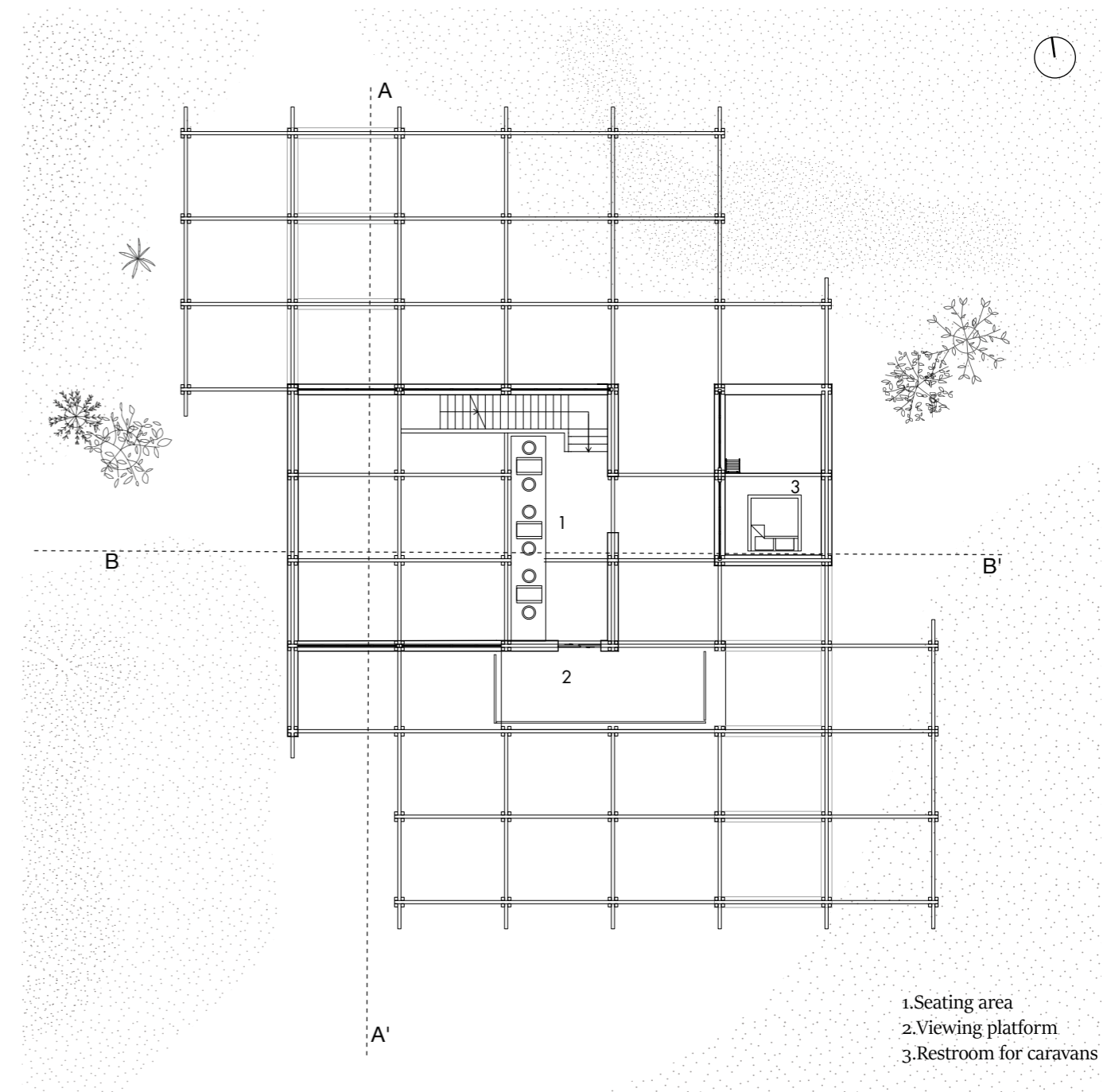

First floor plan

- 1. Seating area
- 2. Viewing platform
- 3. Restroom for caravans

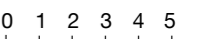

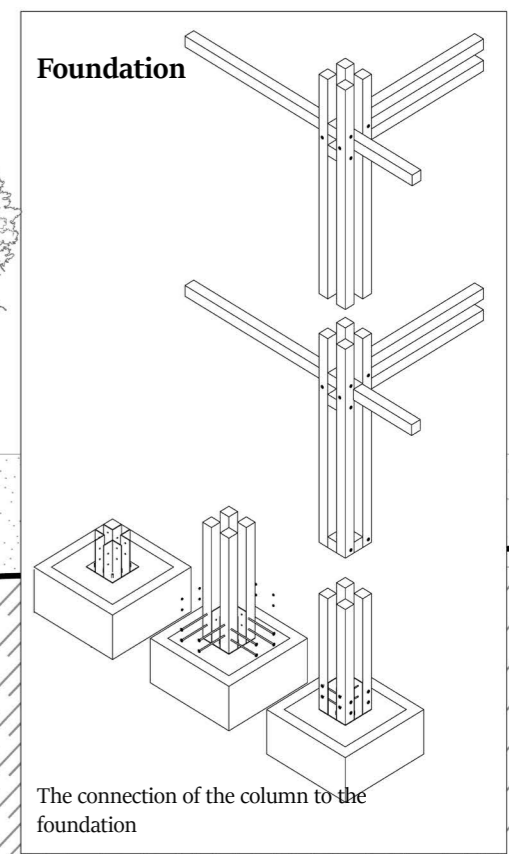
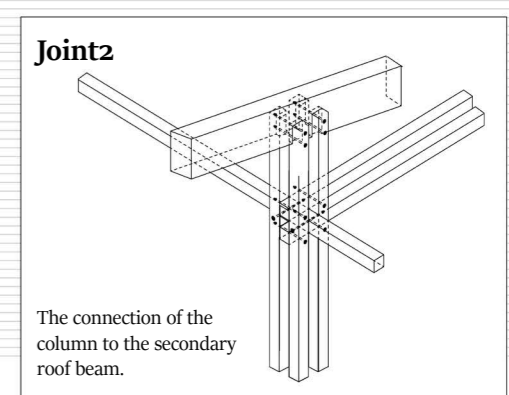
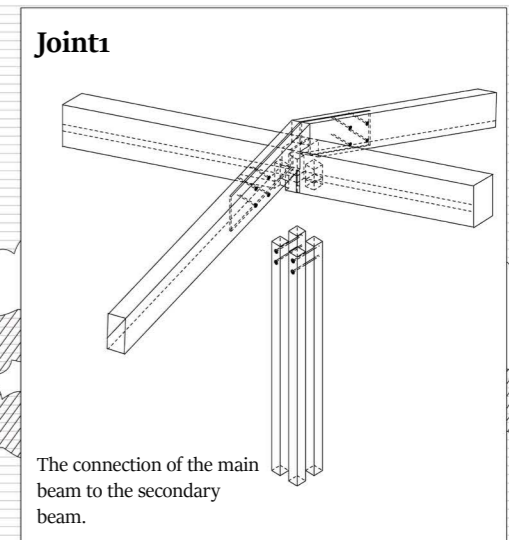
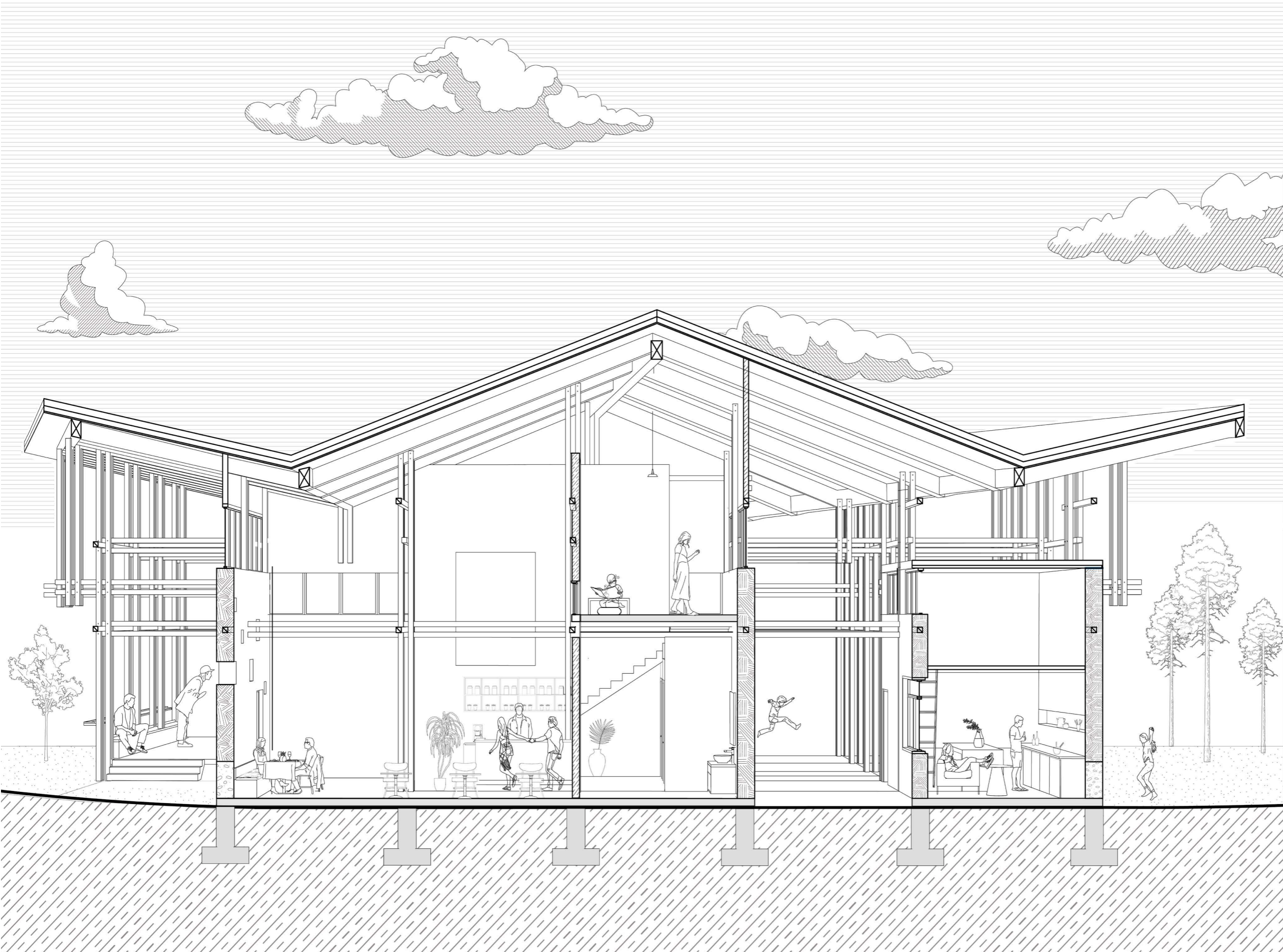

Section B-B'

TOPOS

EXPLORATION OF THE MEMORY ON PHOENIX ROAD



Topos is from the words **Topophilia**.

Derived from the Greek words topos (place) and philia (love), it refers to the positive emotions and aesthetic appreciation people experience toward certain environments.

Model



Model

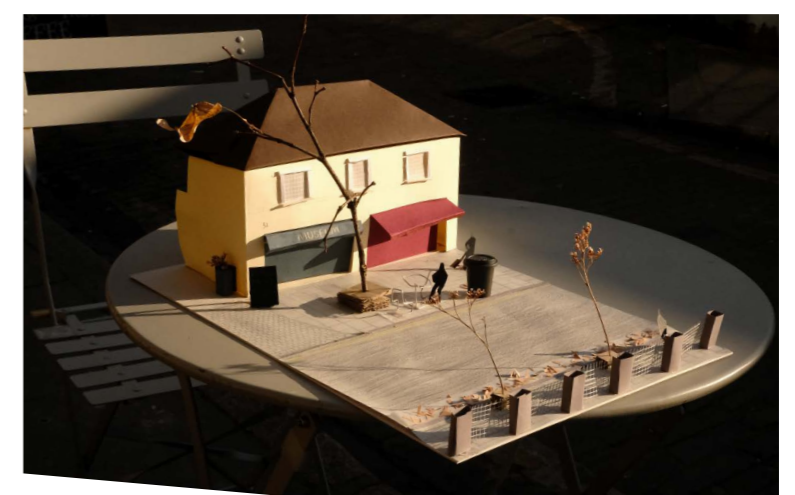
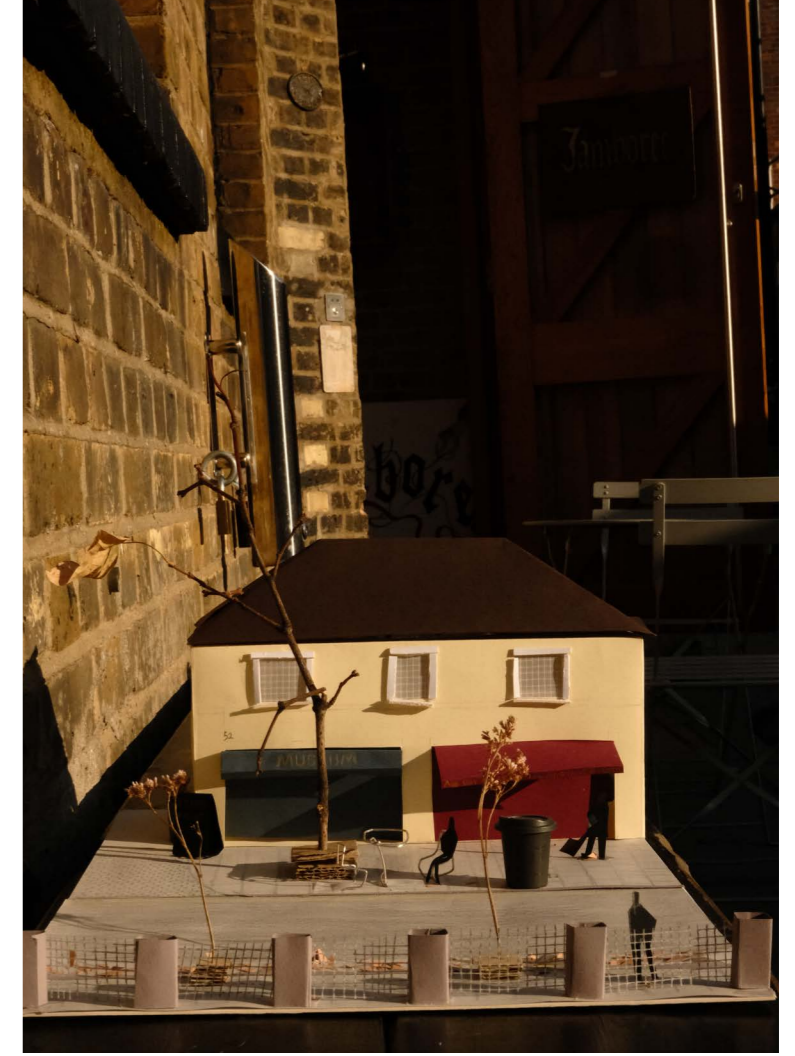

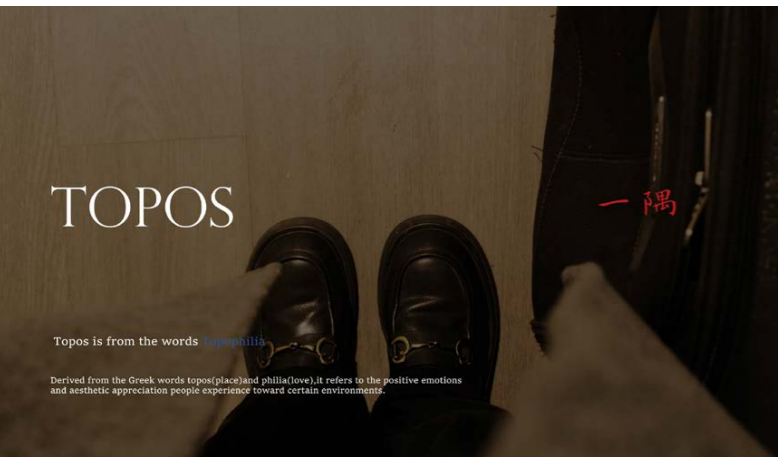

TOPOS

Topos is from the words *topos* (place) and *philia* (love), it refers to the positive emotions and aesthetic appreciation people experience toward certain environments.

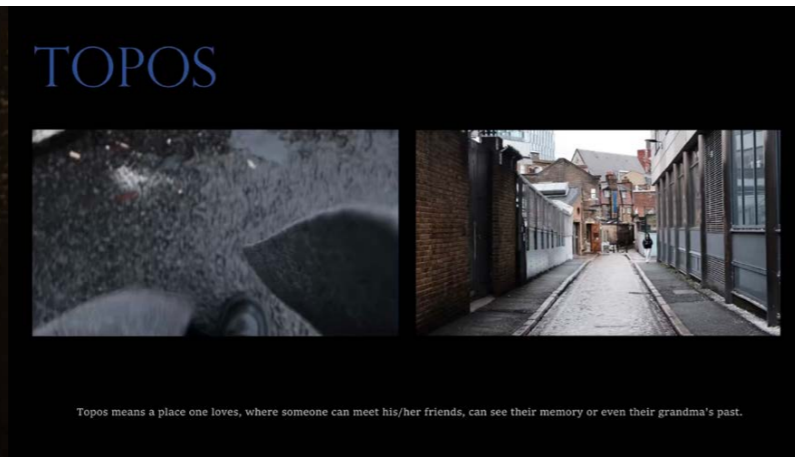

TOPOS

Topos means a place one loves, where someone can meet his/her friends, can see their memory or even their grandma's past.



PHOENIX ROAD

Phoenix road is selected as my whole site to study how people experience on street through time.



COLLECTIVE MEMORY

The second is collective memory.



MUSEUM

Most people come here are old people. Some are from Somers town. Some are not.

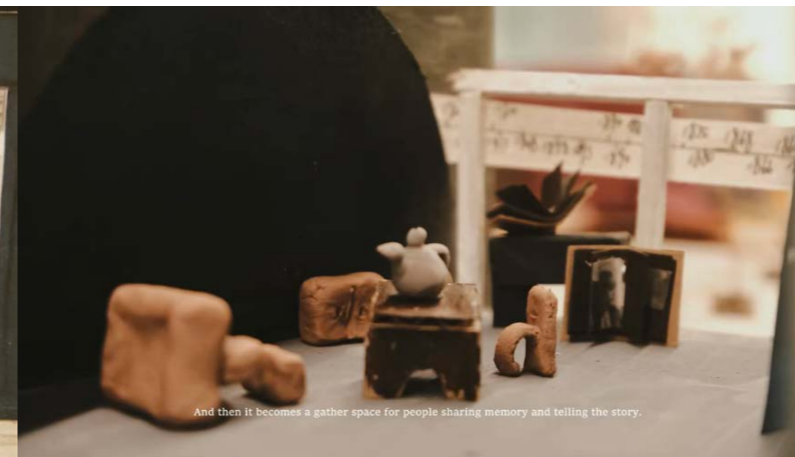

And then it becomes a gather space for people sharing memory and telling the story.



COCK TAVERN

This old pub stands here for hundreds year. Parties and marriage happened on the second floor.

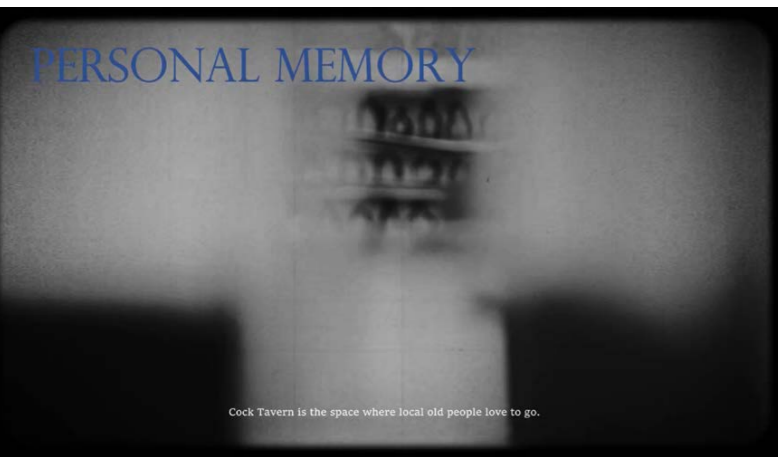

PERSONAL MEMORY

Cock Tavern is the space where local old people love to go.

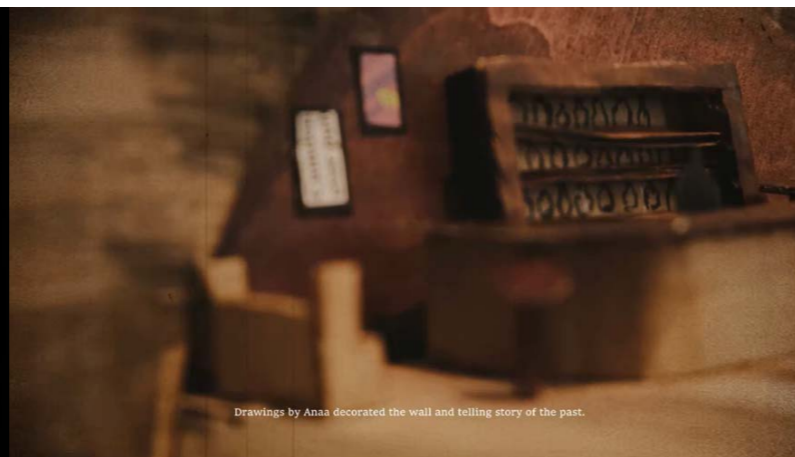

Drawings by Anaa decorated the wall and telling story of the past.



Through an interview, I know that they come here twice a week to meet their friends and drink beer.



THE END

At the end, only tree will remember everything.

Video

Available at: <https://www.youtube.com/watch?v=aQJwqaKPhfY>

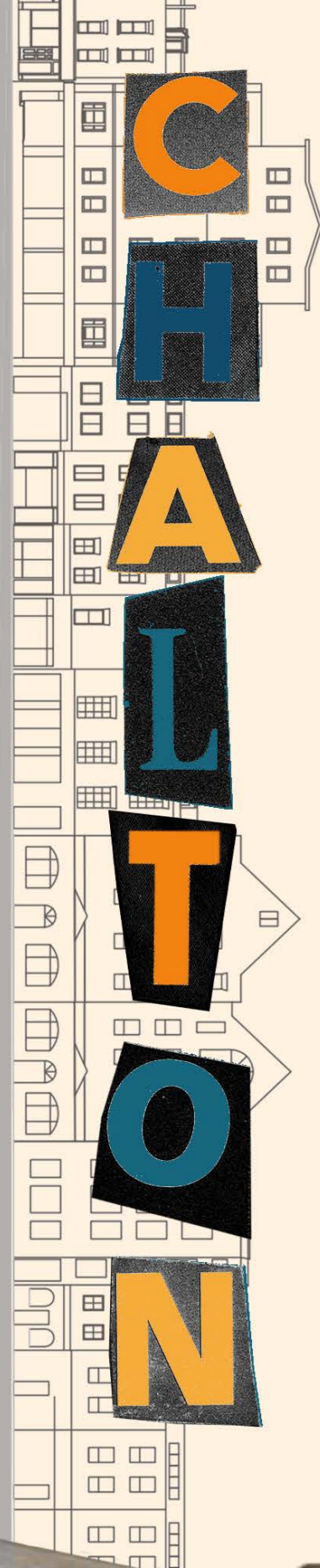

C
H
A
L
T
O
N

S
T
R
E
E
T



PROJECT SUMMARY

Inspired by Henri Lefebvre's concept, our project seeks to revitalize Chalton Street Market as a dynamic, inclusive space that fosters social interaction and community resilience. By reclaiming public space from the pressures of industrial urbanisation, we aim to create a vibrant, people-centered environment in the heart of Somers Town.

Through conducting comprehensive public engagement exercises, analyze relevant local policies, and study successful market precedents across London. Our proposal envisions a Friday-to-Sunday market with a combination of permanent and temporary stalls and street furniture, offering street food, handicrafts, and artworks from local residents, external traders, and nearby institutions.

This will function as more than a commercial hub. It will provide opportunities for cultural exchange, foster economic resilience, and serve as a space for collective gathering and everyday leisure. By strengthening the neighborhood's social fabric, the market will support both local livelihoods and the broader urban experience.

Research Question:

Has architecture the tools to propose an alternative idea about the city at a time where the environment is being shaped by global economics at a speed beyond planning control?



CHALTON
MARKET

SITE - PHOTOS, MAPS

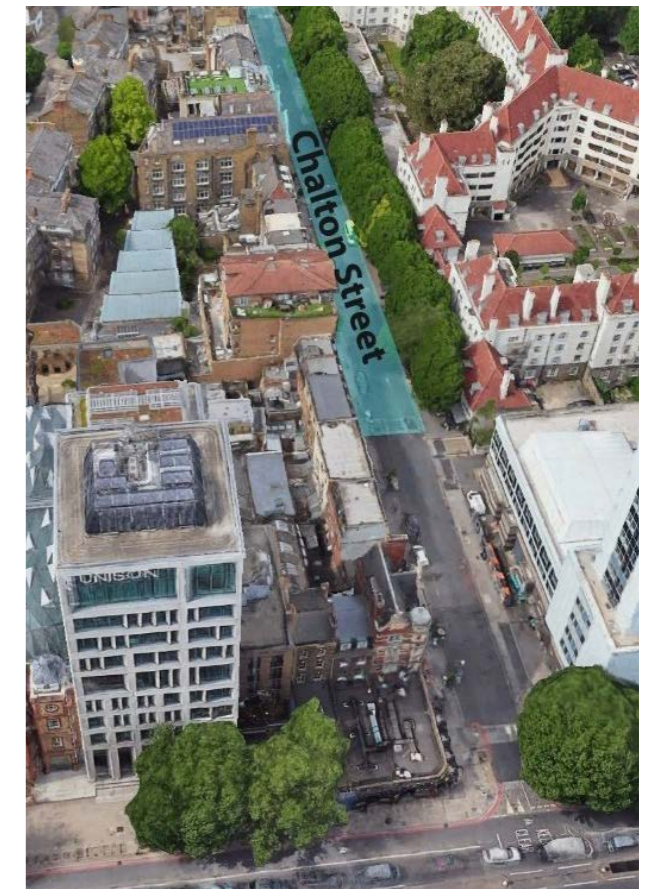
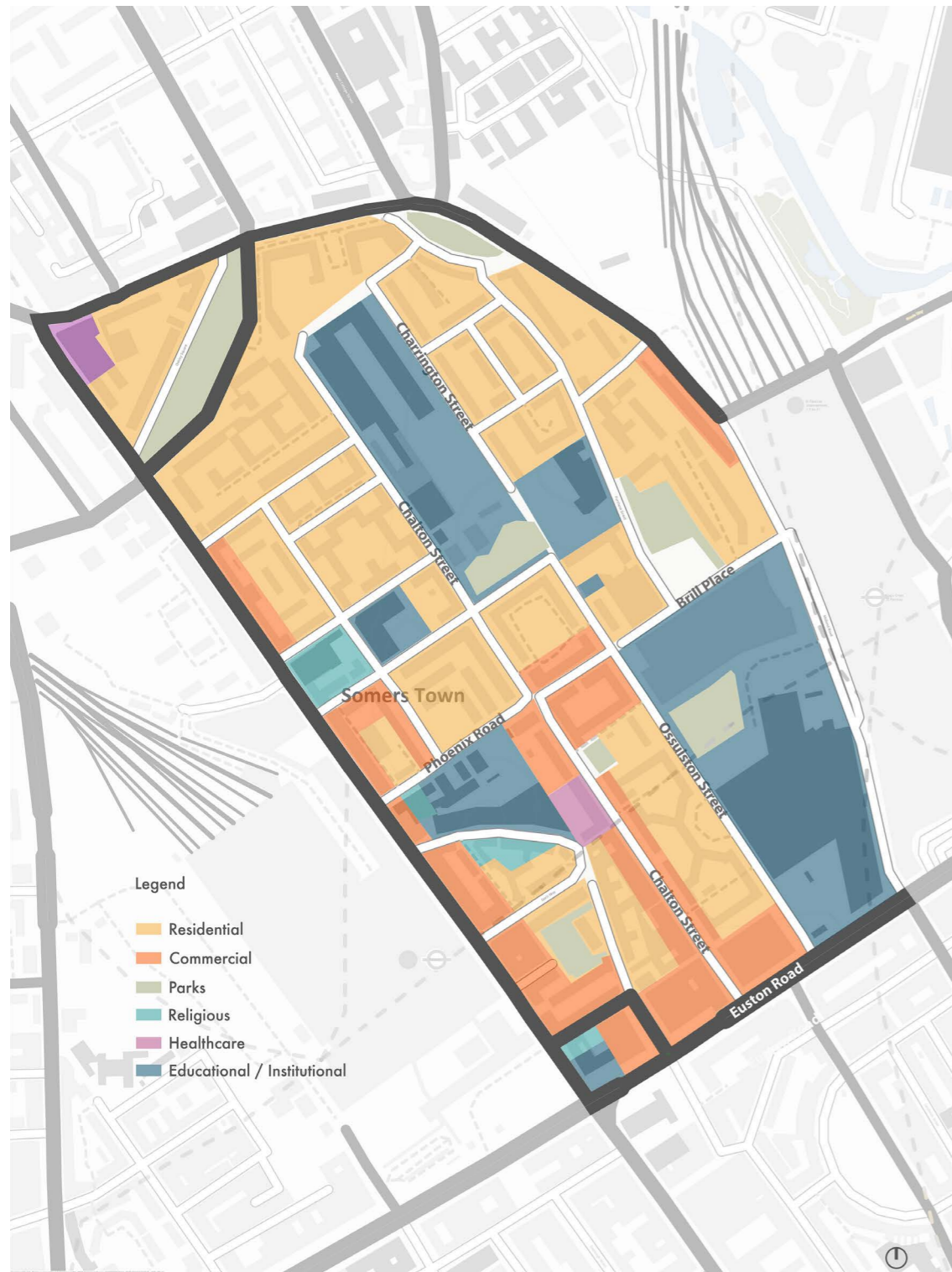

Chalton Street Market stretches approximately 300 meters from Euston Road to the Somers Town Coffee House, within a commercial area of ground-floor shops. Every Friday, the street is closed to vehicles to create a pedestrian-friendly market space, where traders sell goods such as clothing and groceries from temporary stalls. Despite its long history, the market has declined significantly, particularly after the COVID-19 pandemic. Recent site visits revealed only three to four active stalls and limited footfall.

Question 2 - What types of market stalls, seating areas, or street features would make the space more welcoming and functional for everyone?

more seating around stalls

more small businesses

Shaded area like canopies to create pluse

Lighting, visible pathways, nice banners

Mixture clothes, food, something for children, fabric home staff

Question 3 - If you could redesign Chalton Street Market, what would you change or add to improve the experience for vendors and shoppers?

more food(BBQ, Asian food, organic)

more clothes(vintage clothes,aesthetics)

events, festivals

Things kids could enjoy (cheaper)

better management

stalls can be foldable, environmental-friendly materials

Information guidance

book

Question 4 - How do you currently use Chalton Street Market, and what aspects of the street and stalls do you value the most?

- More seating

- Advertising and promotion of the market

- Variety of stalls

- Flexibility and portability, size

- Better quality stalls, vendors, and goods

Question 5 - Can you sketch or describe a market stall or street setup that you think would work best for Chalton Street?

- Have a roof covering of some sort

- Foldable, consistant, organized stalls

- Signage

- Weather-resistant

- Open to the street

- Space for cars to pass

PUBLIC ENGAGEMENT



During the public engagement process, a resident involved in the organization of the market shared valuable insights regarding ongoing community initiatives. According to the resident, there are active efforts within the local community to revitalize Chalton Street Market in response to its recent decline. In parallel, the community is seeking financial support by applying for funding from Camden Council to assist with the development and implementation of their project.



STAKEHOLDER DIAGRAM

Regarding project stakeholders, we propose involving traders from Somers Town and nearby institutions, such as local schools and the British Library, along with a limited number of external vendors.

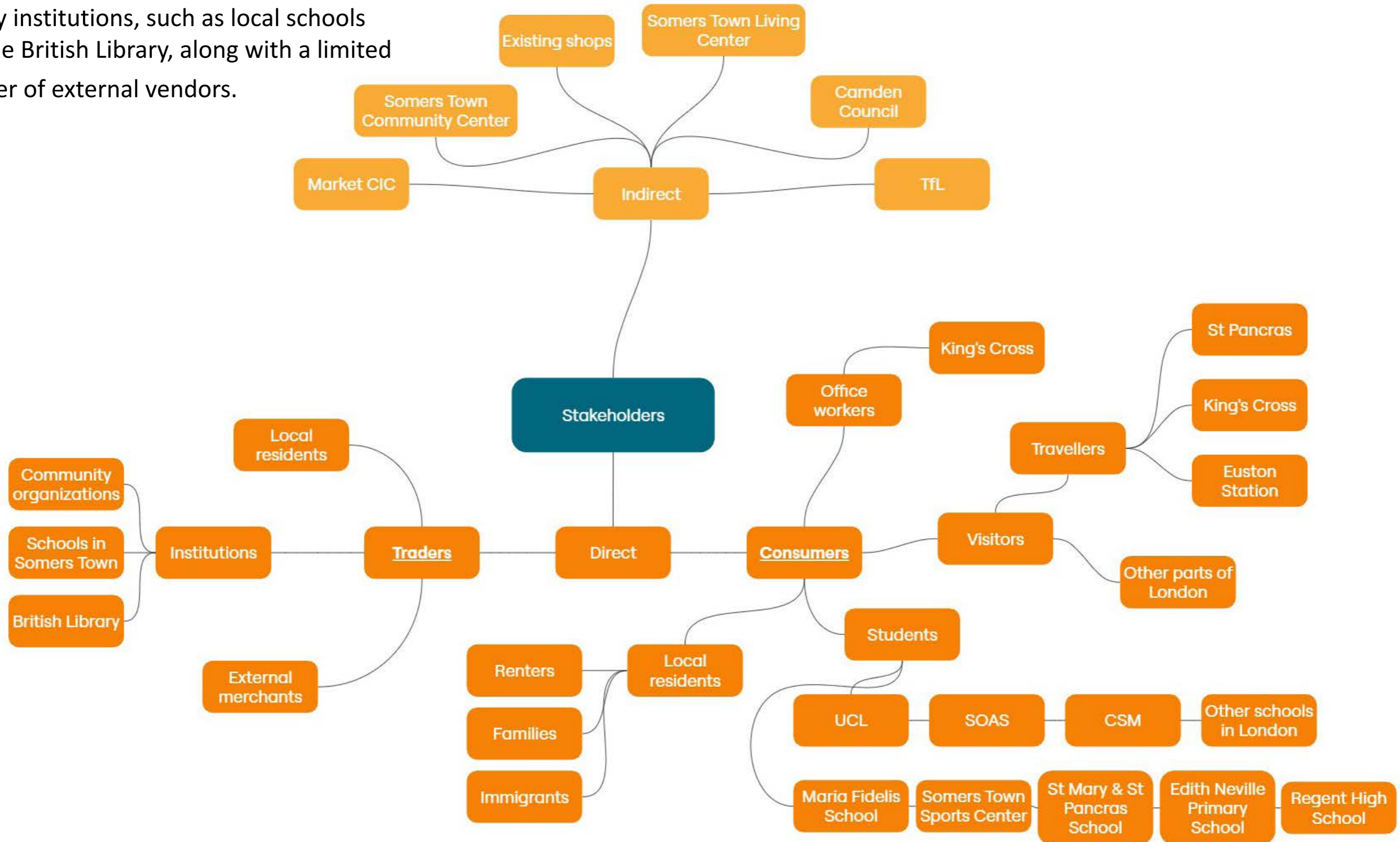

PHYSICAL MODEL



VIDEO LINK

<https://www.youtube.com/watch?v=dnfAugGHUOE>

DESIGN - AXON, STORYBOARD

1. Children

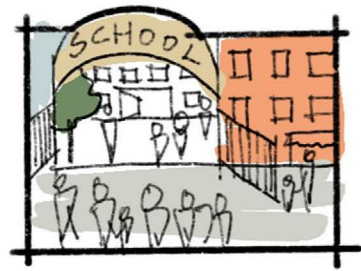

1.1 Parents waiting to pick up their kids on a Friday afternoon.

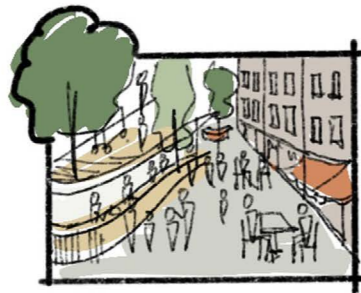

1.2 Going to the Chalton Street Market after school to get some snacks.



1.3 Friends from school play together and got attracted by the stall selling handmade toys.



1.4 Going back home together.

2. Residents

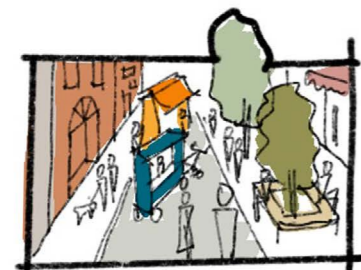

2.1 The new Chalton Street Market offers a more friendly environment for social gathering with more seatings and diverse stalls.

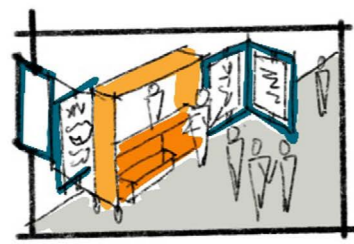

2.2 Residents can learn about community events and job and service opportunities from the display stall. Or sell their artworks!

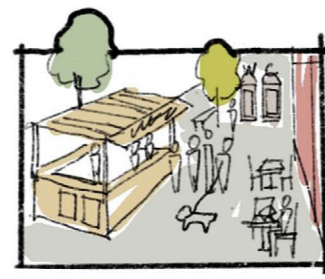

2.3 The food stalls always attract more people. Added portable toilets in the background.

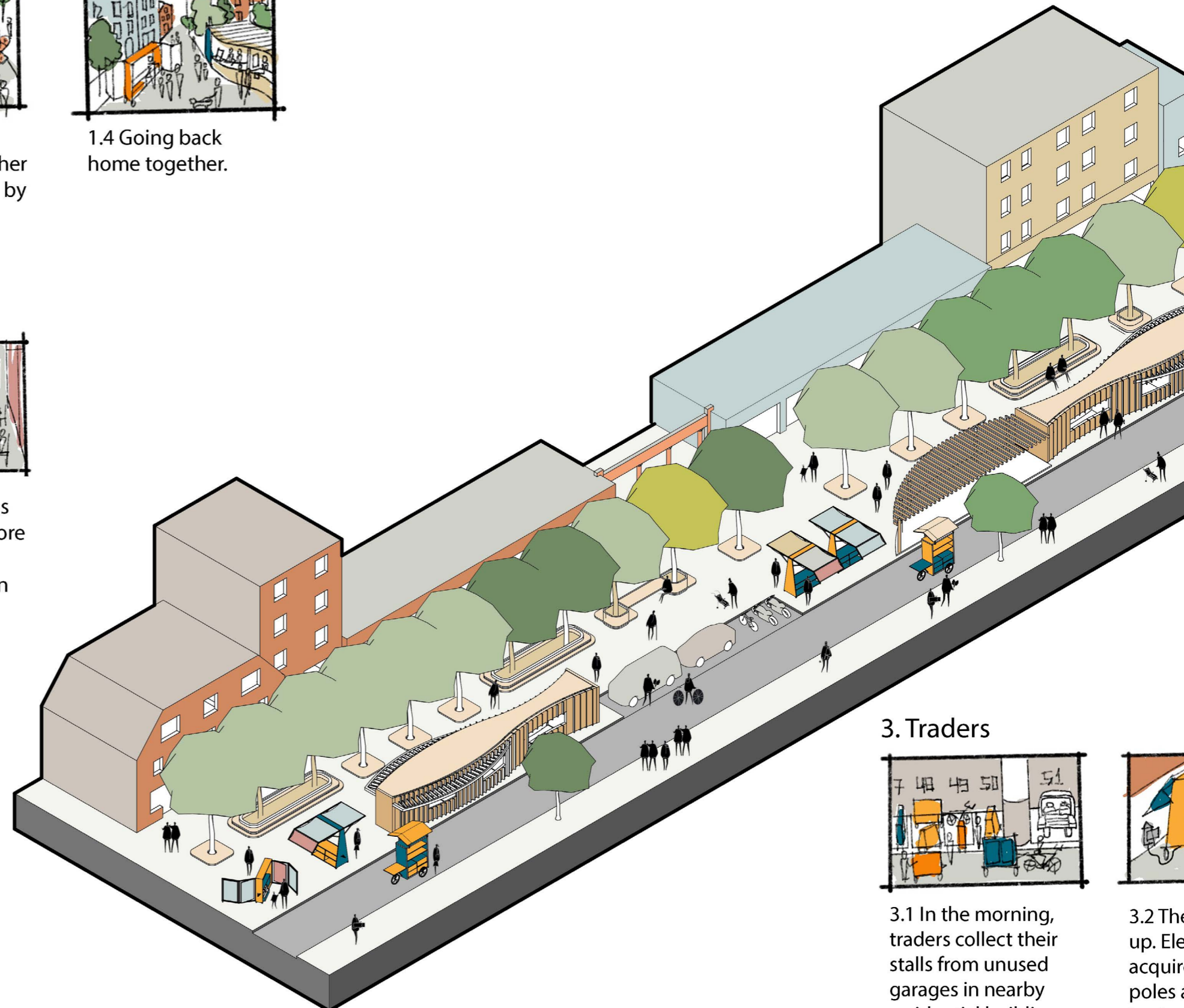

3. Traders

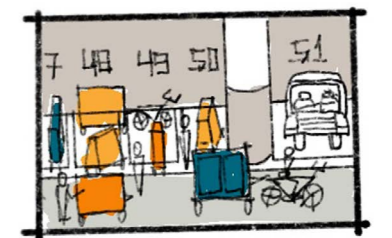

3.1 In the morning, traders collect their stalls from unused garages in nearby residential buildings.



3.2 The up. Ele acquiring poles and both s street.

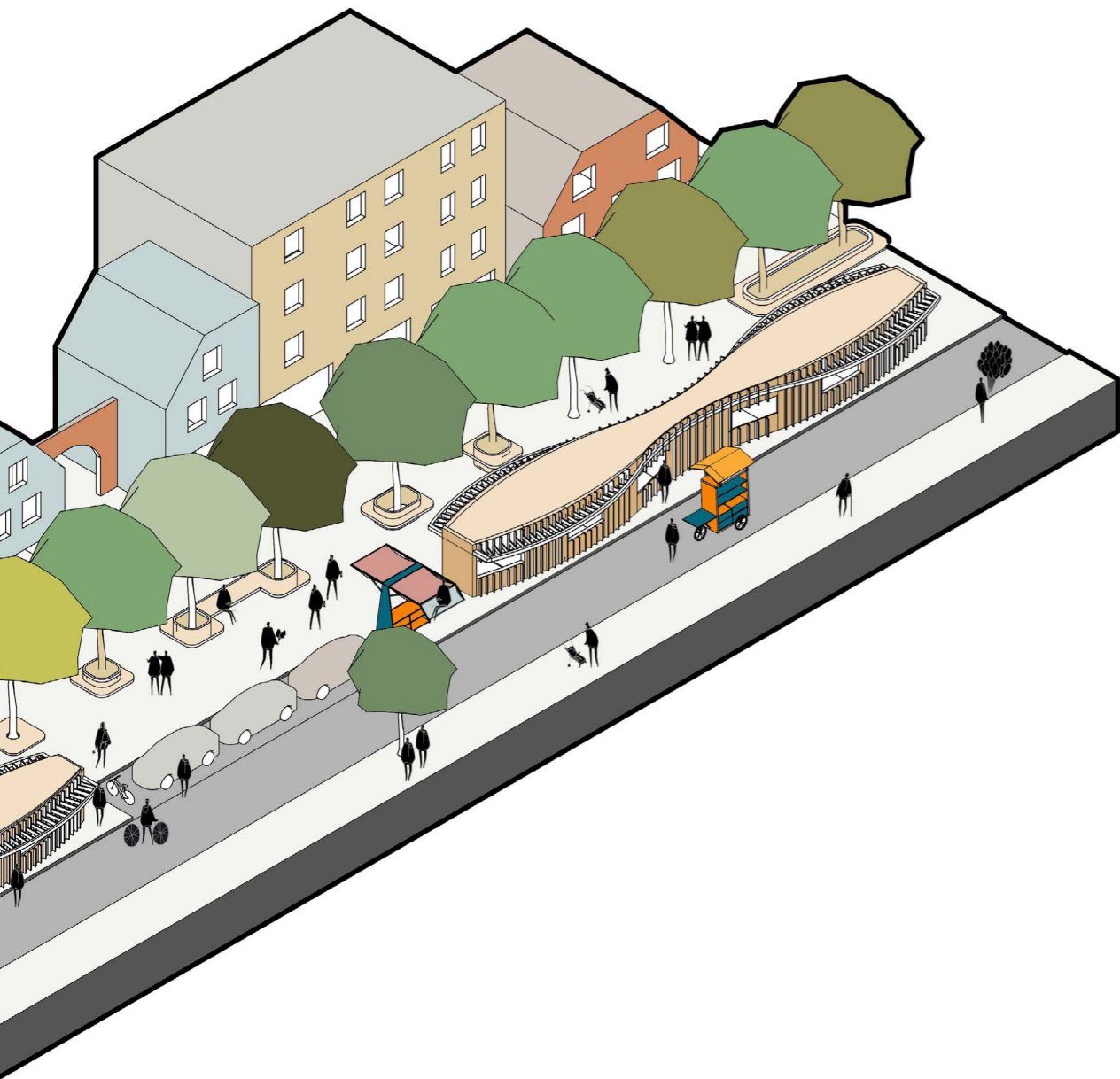

From 3 angles, these scenes imagine how different people could experience the market and logistical considerations of the market management.

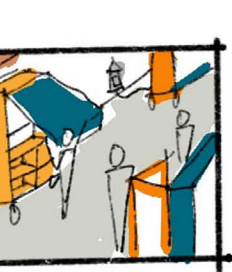

They start setting
electricity can be
used from the
available on
side of the

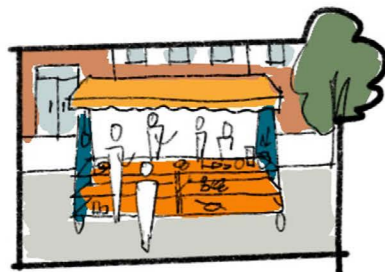

3.3 The busiest time
starts from noon.

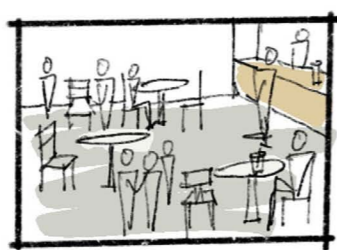

3.4 Traders's meeting
is led by a
community
representative who
organizes the
market and speak to
the council.



3.5 As before, trash
is collected near the
gate on Euston road
daily.



DESIGN OF STALLS

Three types of stalls are developed. While designing, we carefully considered the needs of the traders and came up with foldable, easily transported, stalls made of wood and coated-fabric.

With council's funding, softwood comes at affordable prices and available from nearby building supplies stores. The coated-fabric shading is weather-proof with a degree for customization and incorporates cultural characteristics.

MATERIAL

Structure:

Wood, Wood Panels

Shading:

Fabric

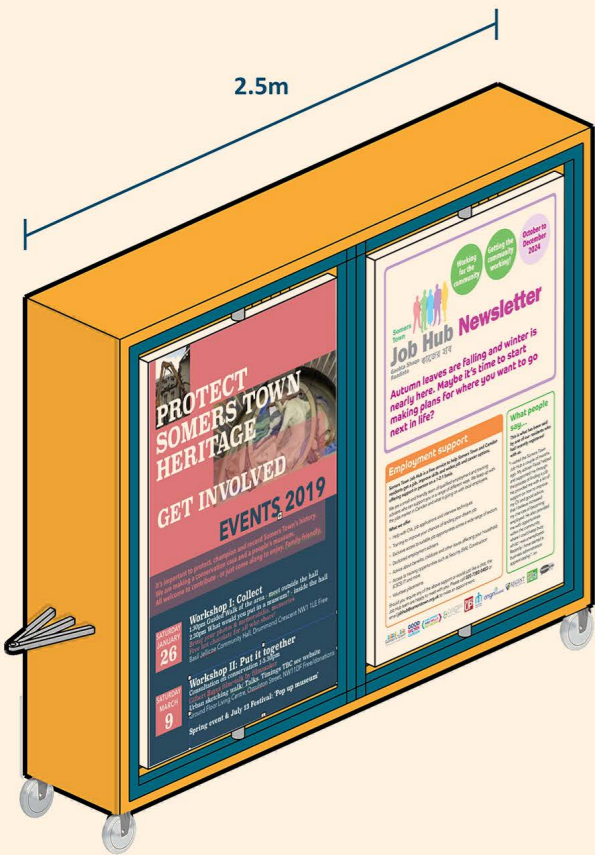
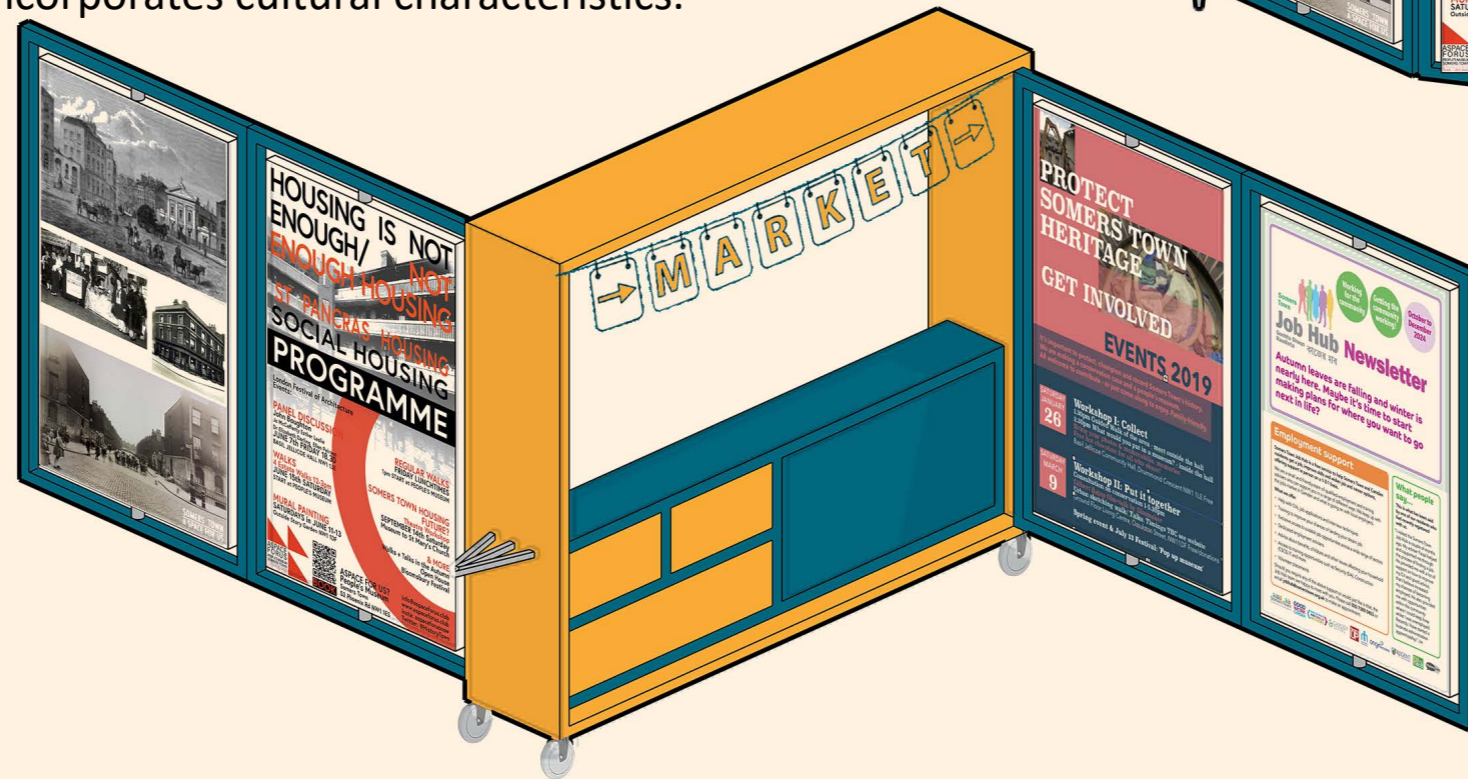
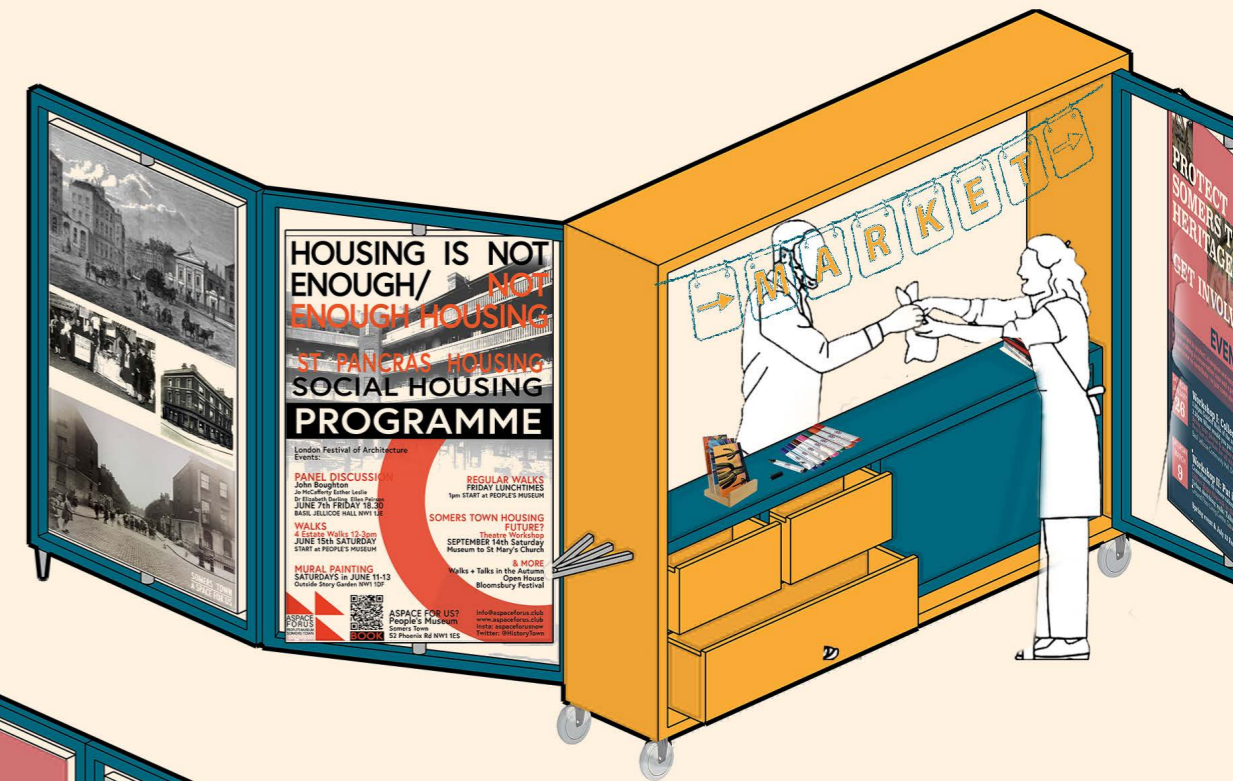

2.5m

2m

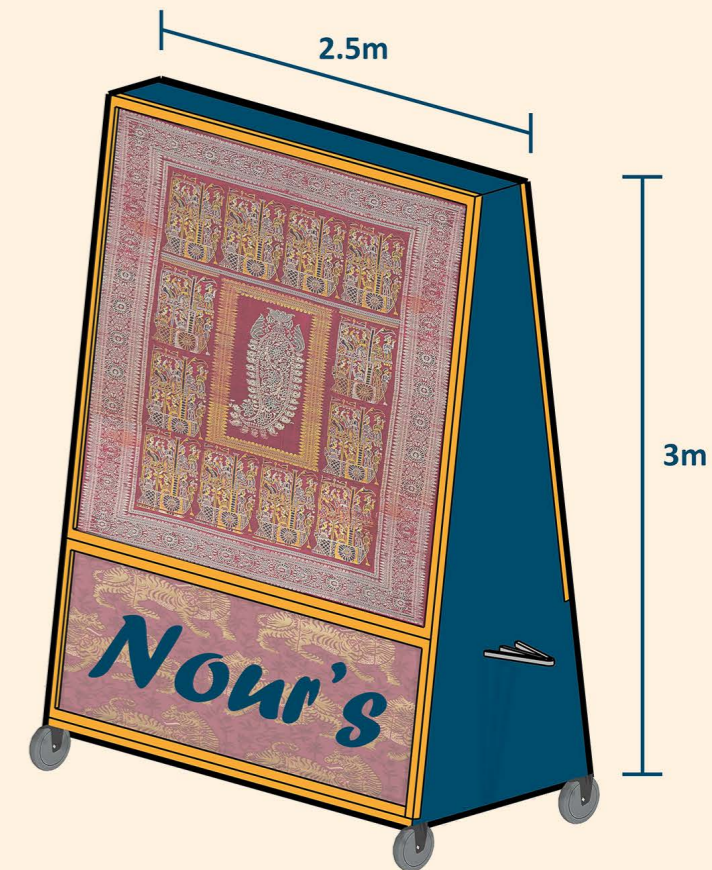
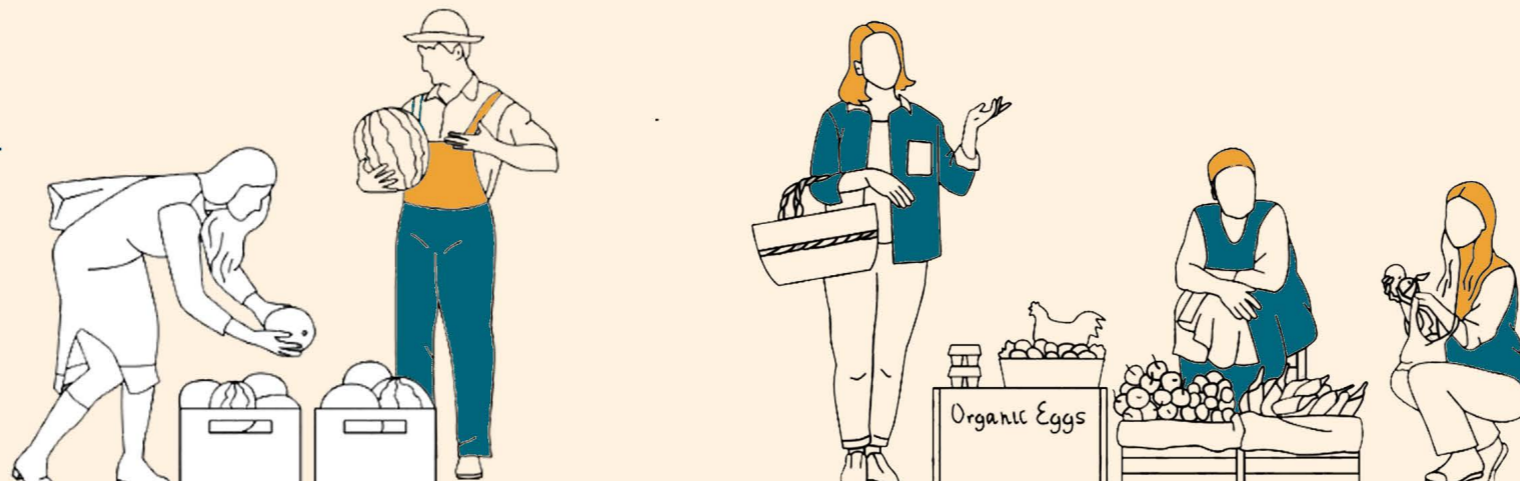

2.5m

3m

STALLS FOR DISPLAY

STALLS FOR SELLING

This is an example of the display stall opened by the somers town community center, promoting housing heritage event and providing information about immigrant job opportunities.

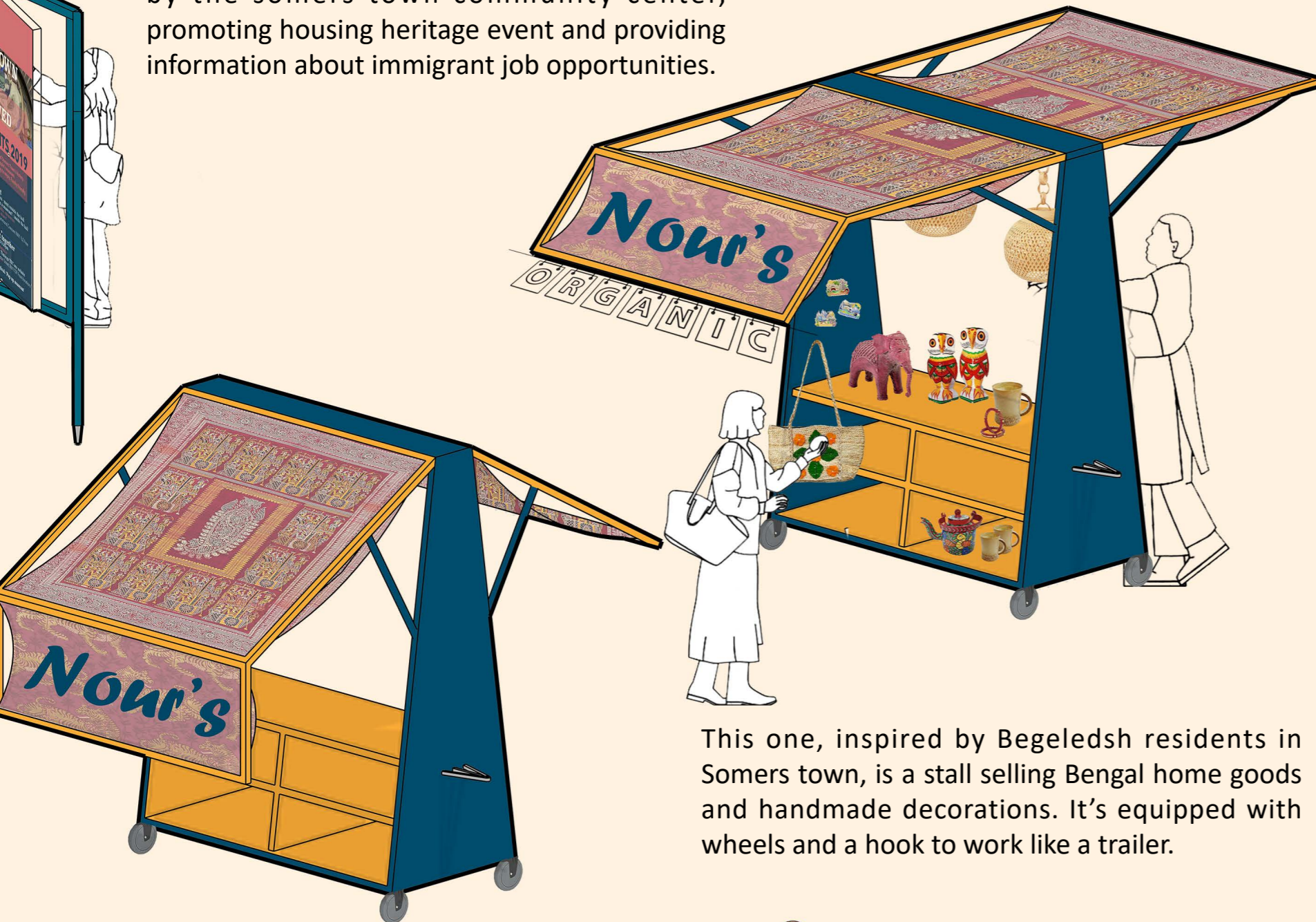

This one, inspired by Begeledsh residents in Somers town, is a stall selling Bengal home goods and handmade decorations. It's equipped with wheels and a hook to work like a trailer.

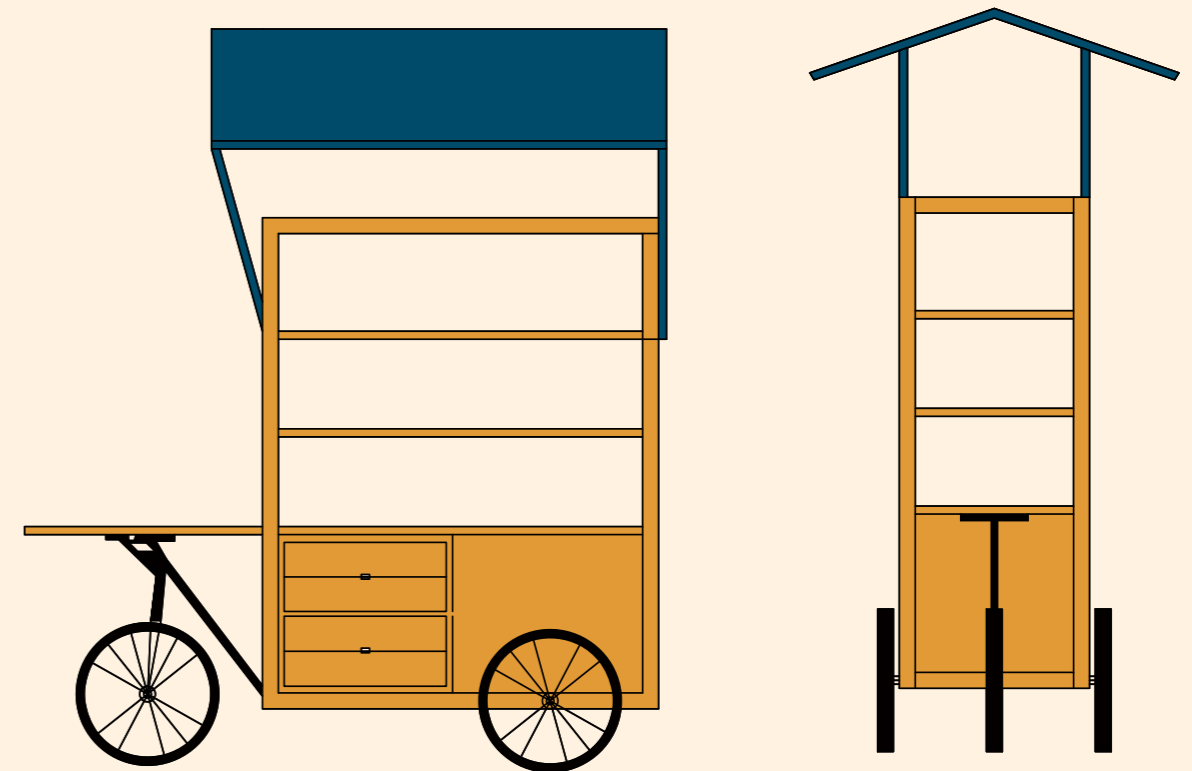

DRIVING STALLS FOR FOOD

THE FITZROVIA CHAPEL

SCAN TO STRUCTURE: INVESTIGATING ARCH DESIGN THROUGH 3D SCANNING



Our understanding of historical structures is constantly evolving, shaped by new perspectives and technological advancements. This project approaches architectural study not purely as a technical analysis, but as a journey into the craftsmanship and spatial language of arches — structures that have long embodied both function and beauty.

Fascinated by the form, construction logic, and symbolic presence of arches, I initiated this project to document, analyze, and reinterpret them through the lens of 3D scanning technologies. Using Fitzrovia Chapel as a case study, the project captures, refines, and digitally reconstructs its intricate vault systems, seeking to uncover the underlying design principles and material expressions.

Rather than merely preserving, the aim is to engage with the structure: translating the historical fabric into digital models, studying its geometry, and producing physical interpretations. The project bridges past and present through three stages: documentation, digital modeling, and structural analysis.

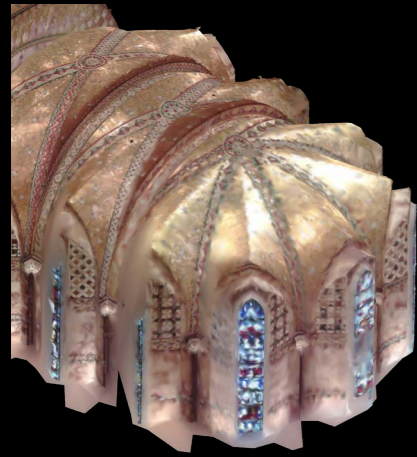

Ribbed Vault
Structure:
Five ribs radiating from the
central apex

Vault System 1

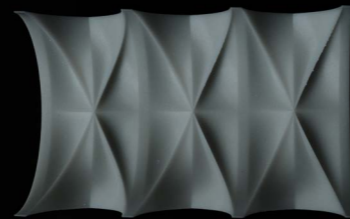

Quadripartite Ribbed Vault
+ Lateral Round Arches

Vault System 2



Quadripartite Ribbed Vault
with Dome

Vault System 3





Jan.2024

THE TASTE BUDS PROJECT

Mapping of Torrao - Through Natural Ingredients

I am the main instructor for this canva painting. Through this creative exploration, we intend to not only document the natural treasures of the area but also celebrate the unique flavors and aromas that define the culinary identity of Torrao, providing a sensory journey that connects people to the essence of this place.



Student List: Lan Wei, Kaiqing Tan, Yilin Wang, Yi Zhang, Haige Li, Jiaxin Qian, Ao Liu, Ruiyan Li, Zike Qiang, Yi Pan, Ruofan Lin, Junli Chen, Beining Zhang, Guangyao Cao, Shengtong Liu, Yigao Liu, Ziyi Huang, Hongxuan Zhu, Matthew Yeung, Peivao Xiao



Jan.2024

“A WHISPER TO AN OLD DREAM” EXHIBITION

Paper City of Torrão & The DIORAMA MAP

On the last day, we exhibited the models, research booklets, drawing canvas and the diorama mapping, inviting the villagers to come and join the exhibition. I was mainly involved in the project of Paper City of Torrão and made the model of the Bell Tower. The objective of this project is to celebrate the town's unique architectural heritage through intricately crafted paper models, offering a microcosmic glimpse into the beauty and essence of Torrao's built environment.



XITLU Faculty: Jess Yu, Zheng Gu **DaST Faculty:** Frederic Coustols, Maria Coustols, Mário Caeiro, Pedro George, Sammy Gao, Vasco Braga, Filipa de Assis, Sara Ibrahim, Angelica Rimoldi