

Academic Projects

3 Radical Housing: A Home for Extroverts

7 Tectonics: Engaging Ecology

11 Tectonics: Spiritual Monumentality

15 Onondaga Street Civic Center

Personal Pursuits

19 Observation Sketch Studies

23 Film Photography Series

Radical Housing: A Home for Extroverts

What if we designed mass housing for those who may not want to pay or use utilities that would go unused in their own space? What about those who search for community and collaboration as home? I aimed to direct interactions between residents to encourage spontaneous social friction. While it may be uncomfortable for most people who have grown up with the normative western approach to personal property, that is the point. I aimed to experiment and encourage alternative thinking that can help combat loneliness and unused space.

ARC-307, Marcos Parga

Rhino + Illustrator +
Photoshop

Fall 2025

My main approach was to group the Day and Night floors, allotting for residents to still have their own personal rooms, but to nudge them to interact through the rest of the program being shared: restrooms, hallways, lounges, kitchen, etc. Secondary circulation cores blend the Day and Night floors further to encourage interaction and interpersonal relationships.

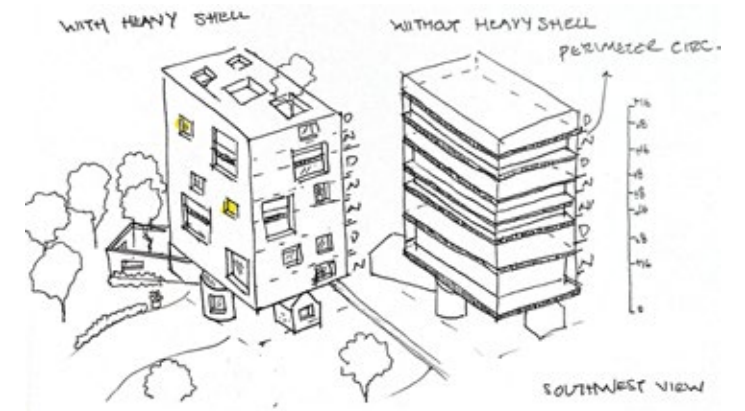

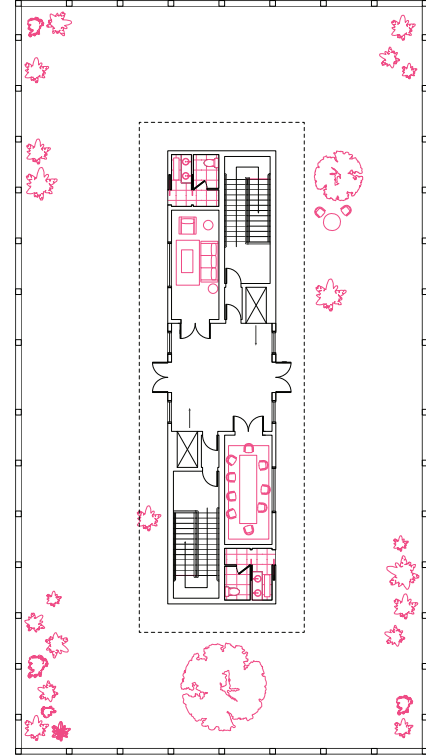
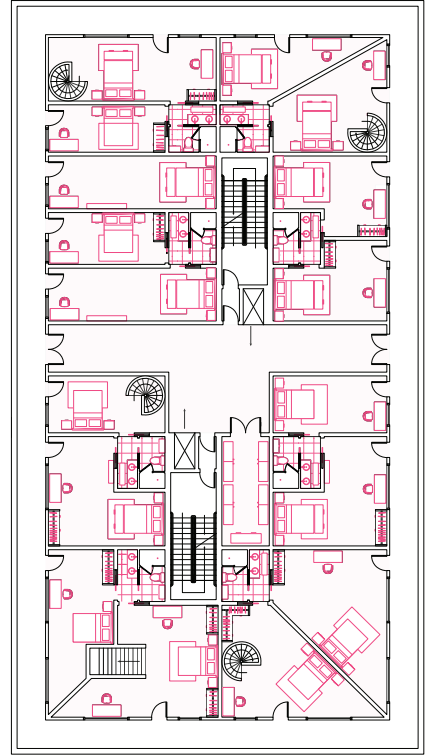
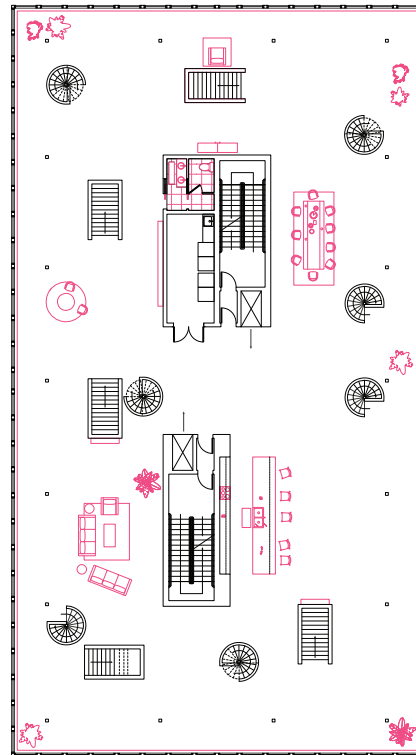
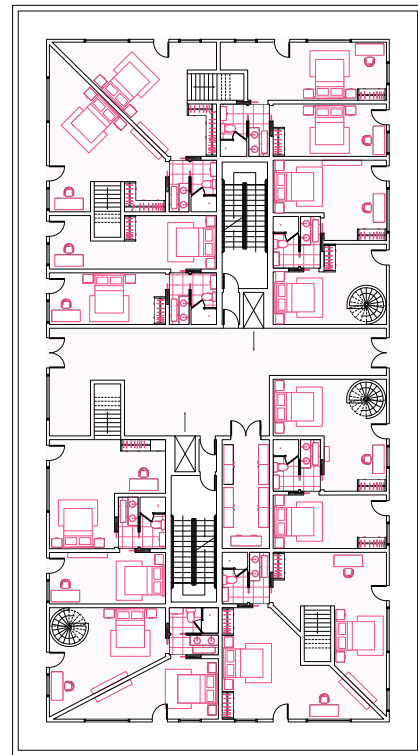
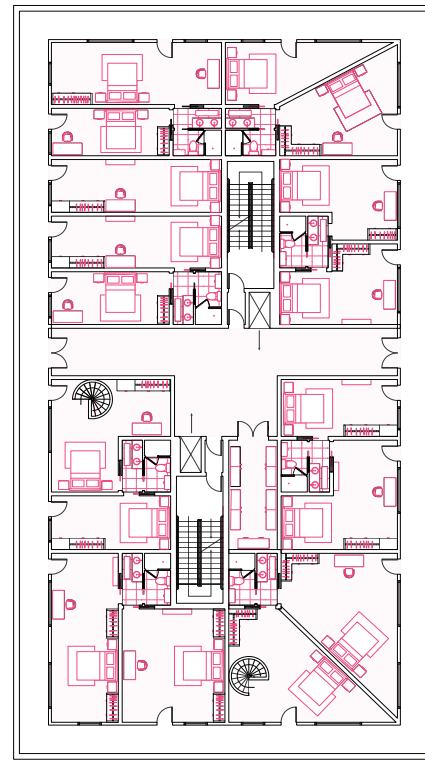
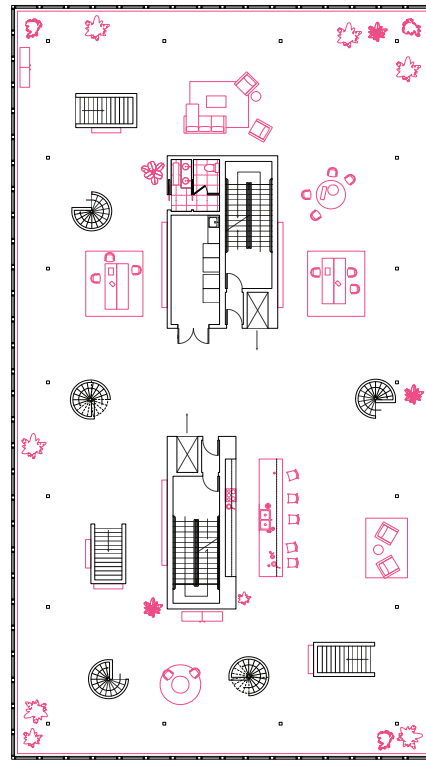
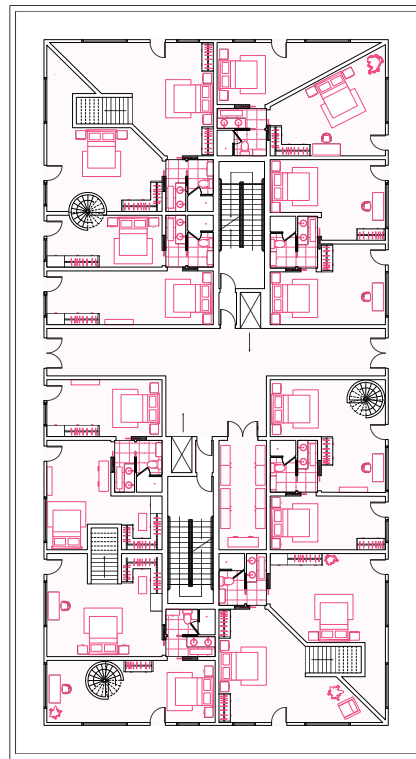
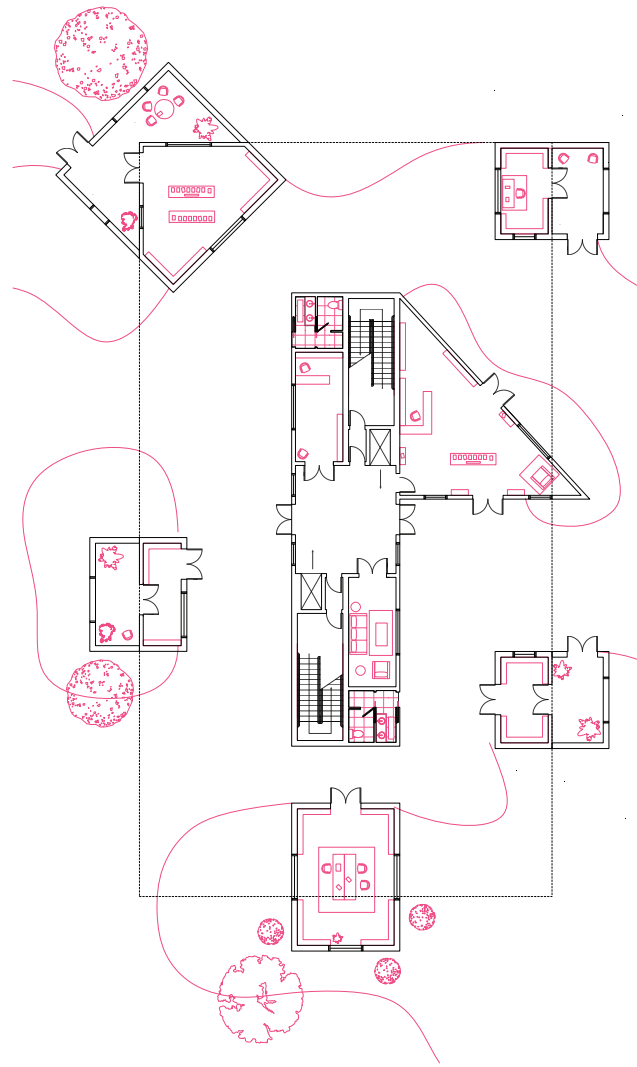

Tectonics: Engaging Ecology

A makers' market situated on the Chicago Riverwalk experimenting with permeability and residual spaces as zones to engage the community in cultivating indigenous ecological species.

ARC-208, Mahwish Khalil

Rhino + Illustrator +
Photoshop

Spring 2025

Meant to act as a mediator between the public and the migratory species of the region, the makers' market uses non-traditional forms to ease the interaction between human and animal uses.

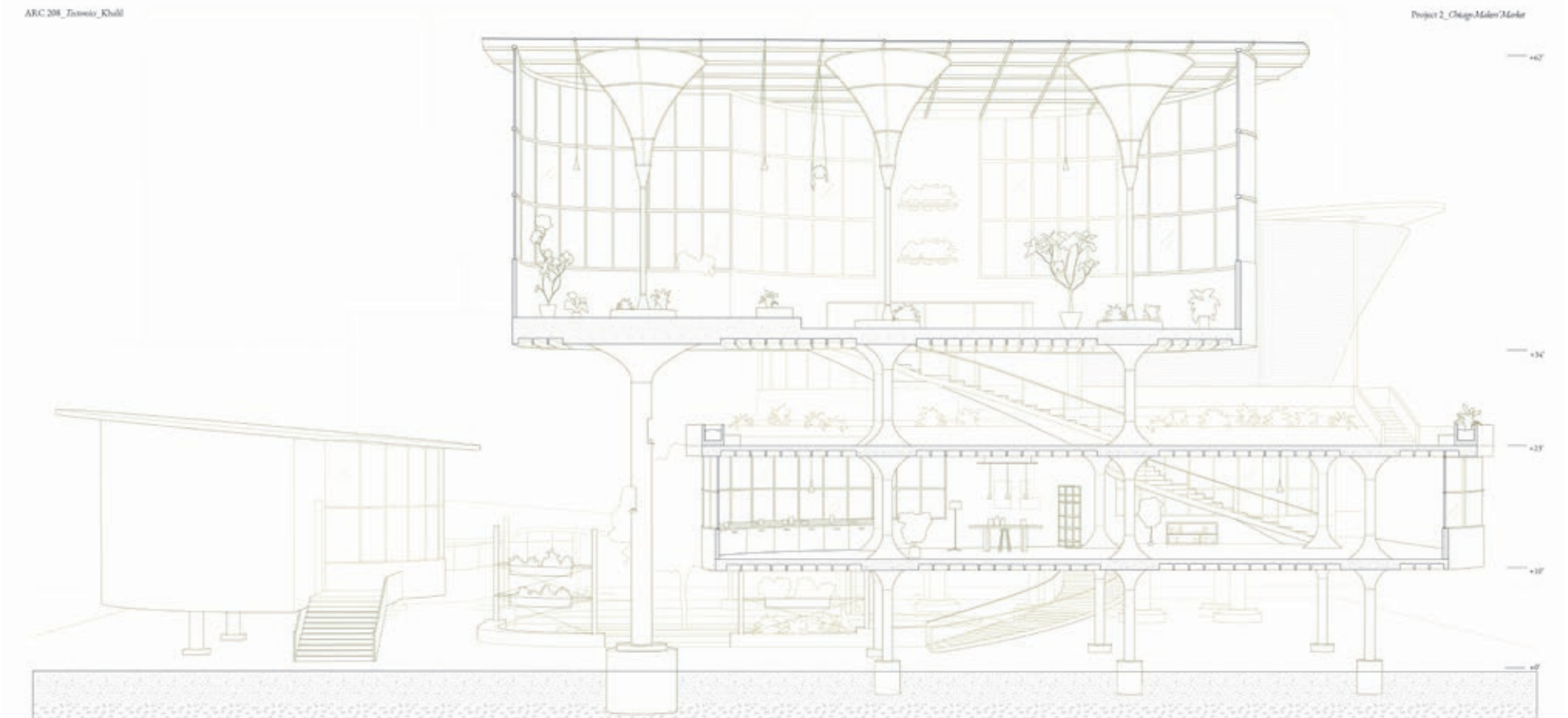

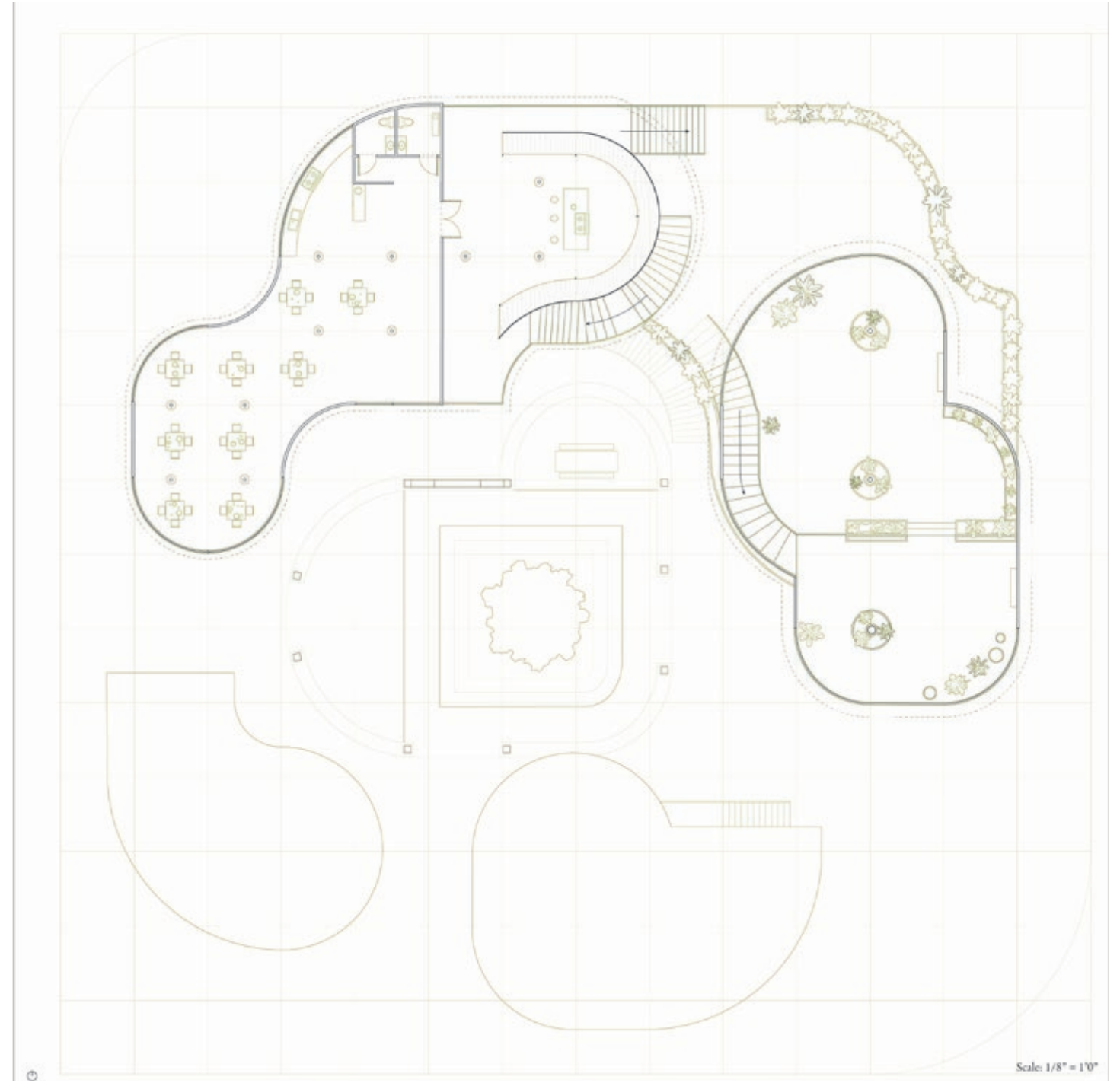

Tectonics: Spiritual Monumentality

Establishing a studio, gallery, and artist residency based off the light work of James Turrell. Form is meant to guide visitors as a means of truly appreciating the intensity of the displays.

ARC-208, Mahwish Khalil

Rhino + Illustrator +
Photoshop

Spring 2025

Contrasting the monumentality of James Turrell's artwork installations and the transparency of Petr Stolin's Nova Ruda Kindergarten, I aimed to design a space encouraging visitors to engage in a spiritually explorative experience.

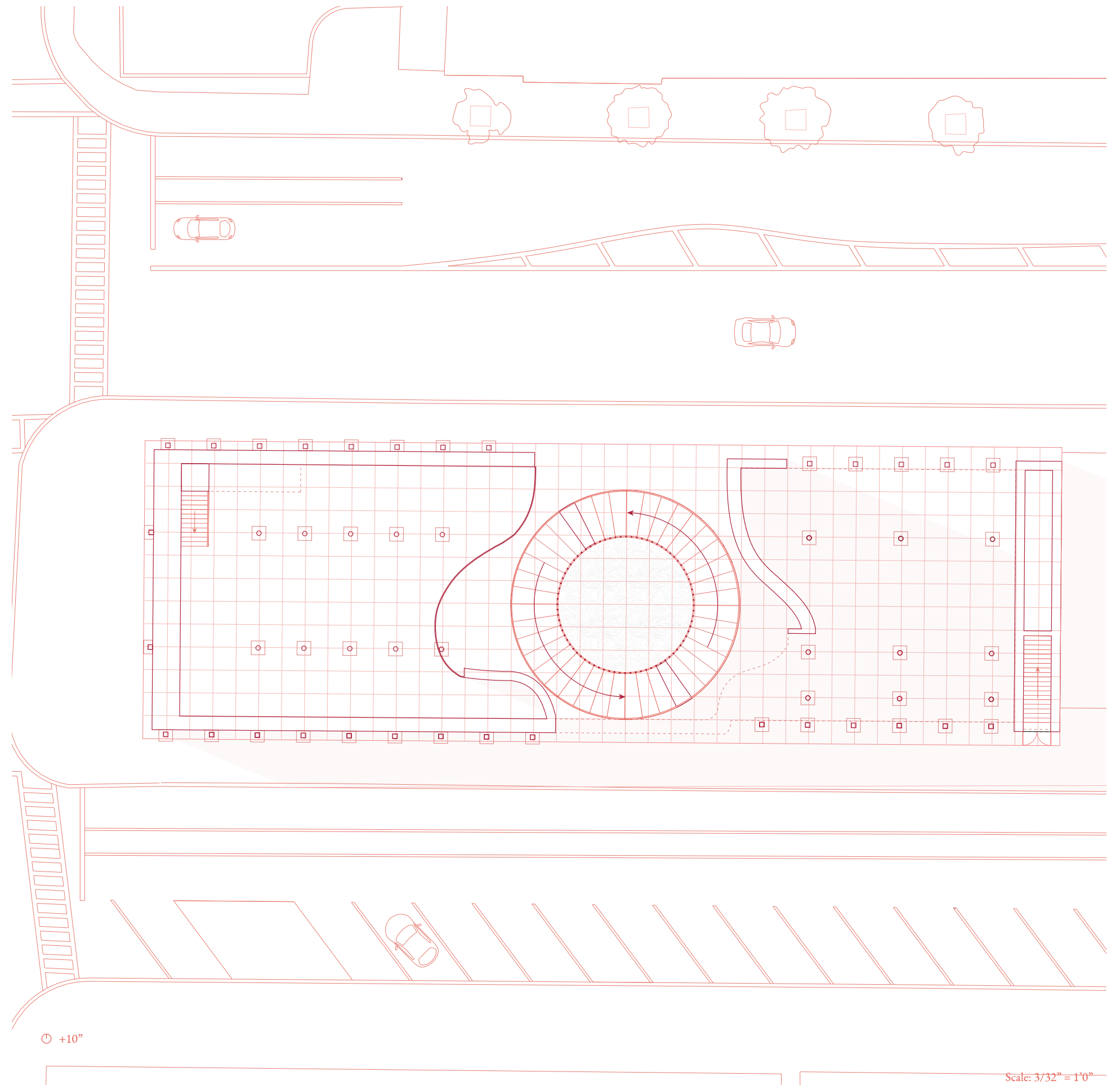

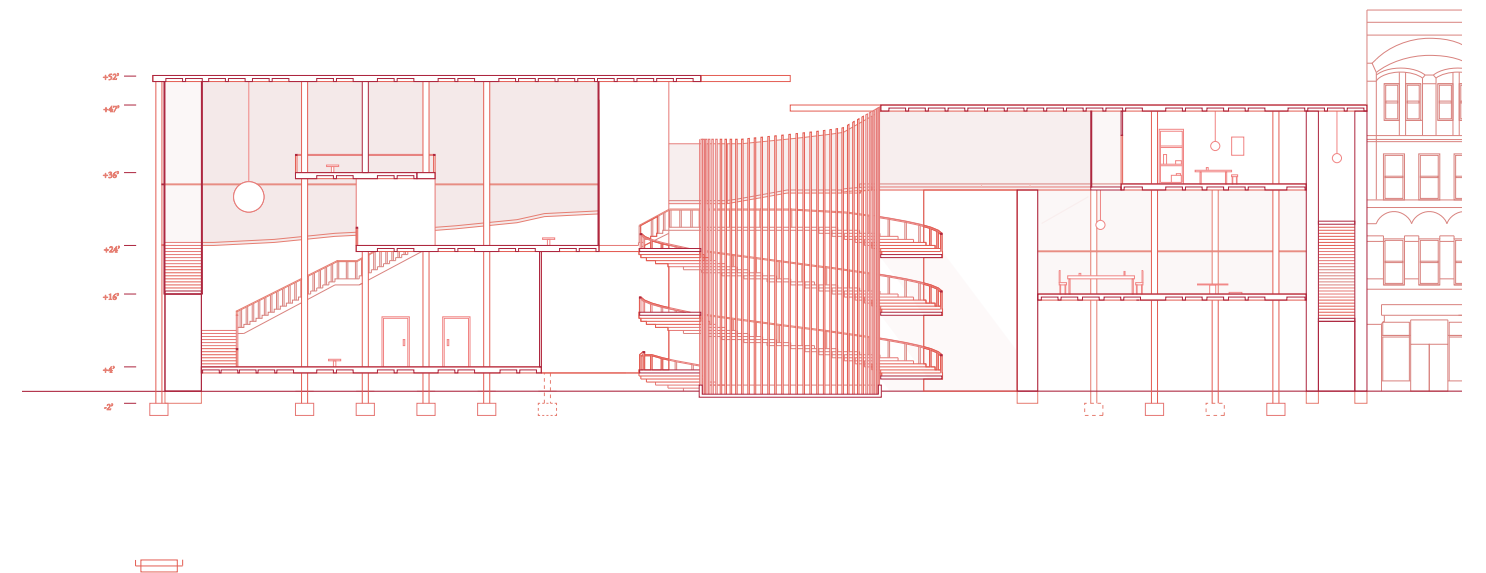
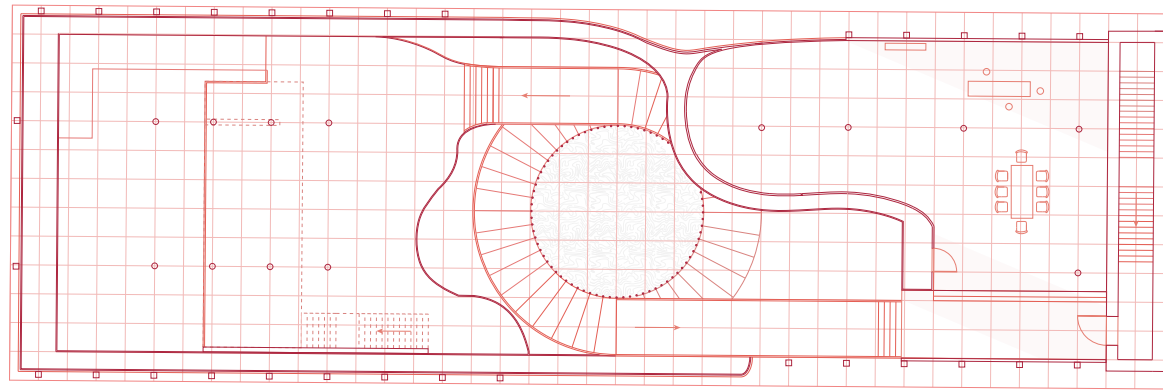
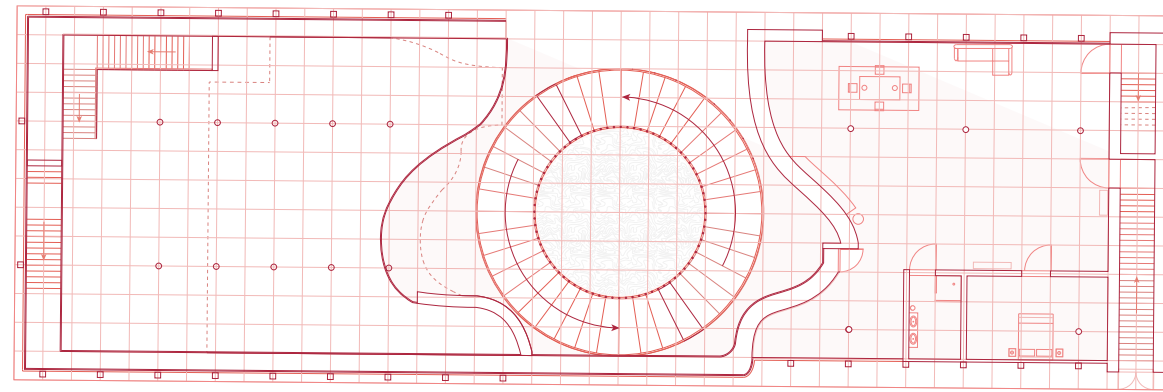
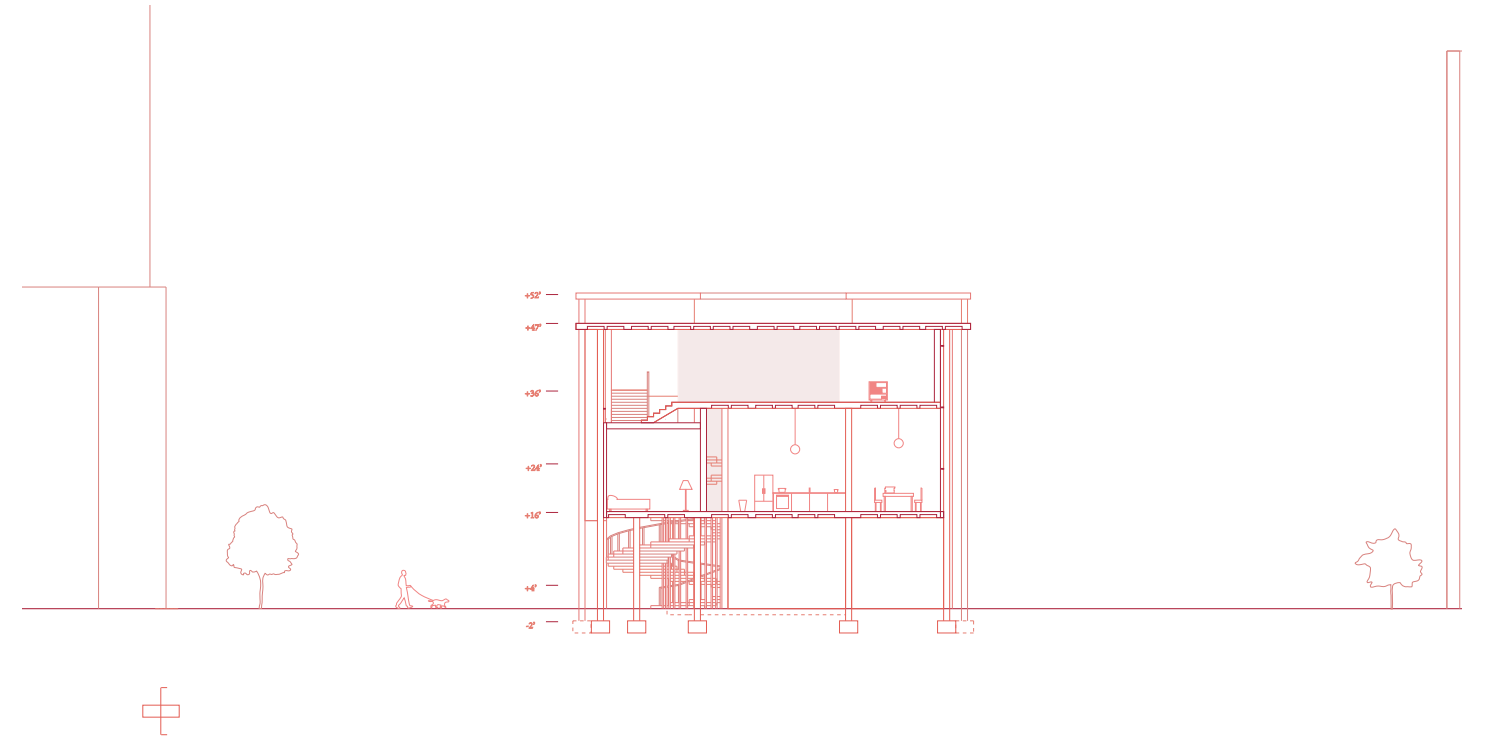
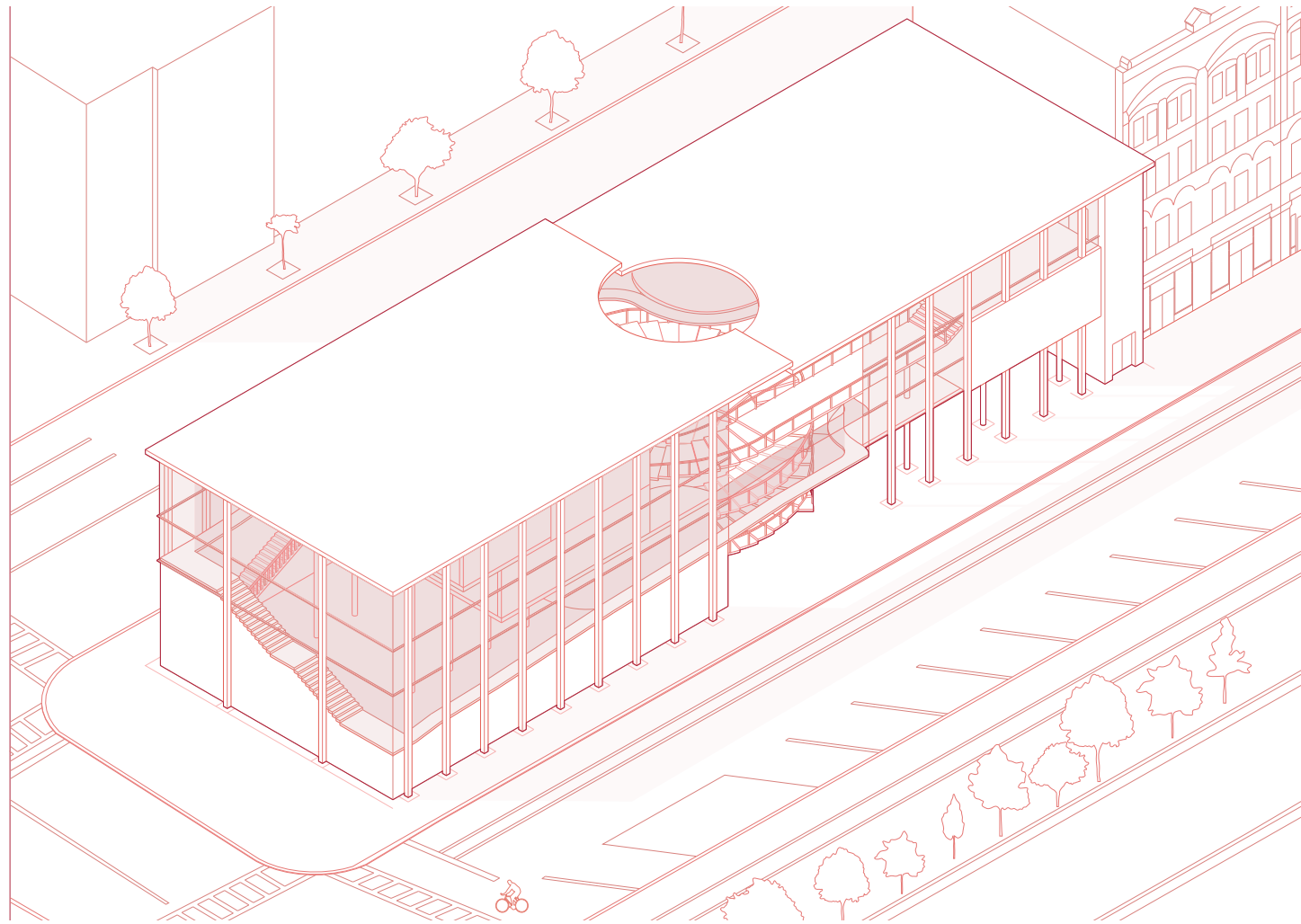

Scale: 3/32" = 1'0"

Onondaga Civic Center

Beginning with a case study analysis of the Gando Primary School by Kere Architecture, and abstracting highlighted aspects of the design to create a new public space.

ARC-108, Magdalena Valdevenito

Rhino + Illustrator + Photoshop

Spring 2024

Transforming the modular frame and column system of the classrooms to create a new cubic enclosure. The modularity of columns inspires the facade mullions and interior column grid of the following design for a Civic Center for 290 West Onondaga Street in Syracuse, New York.

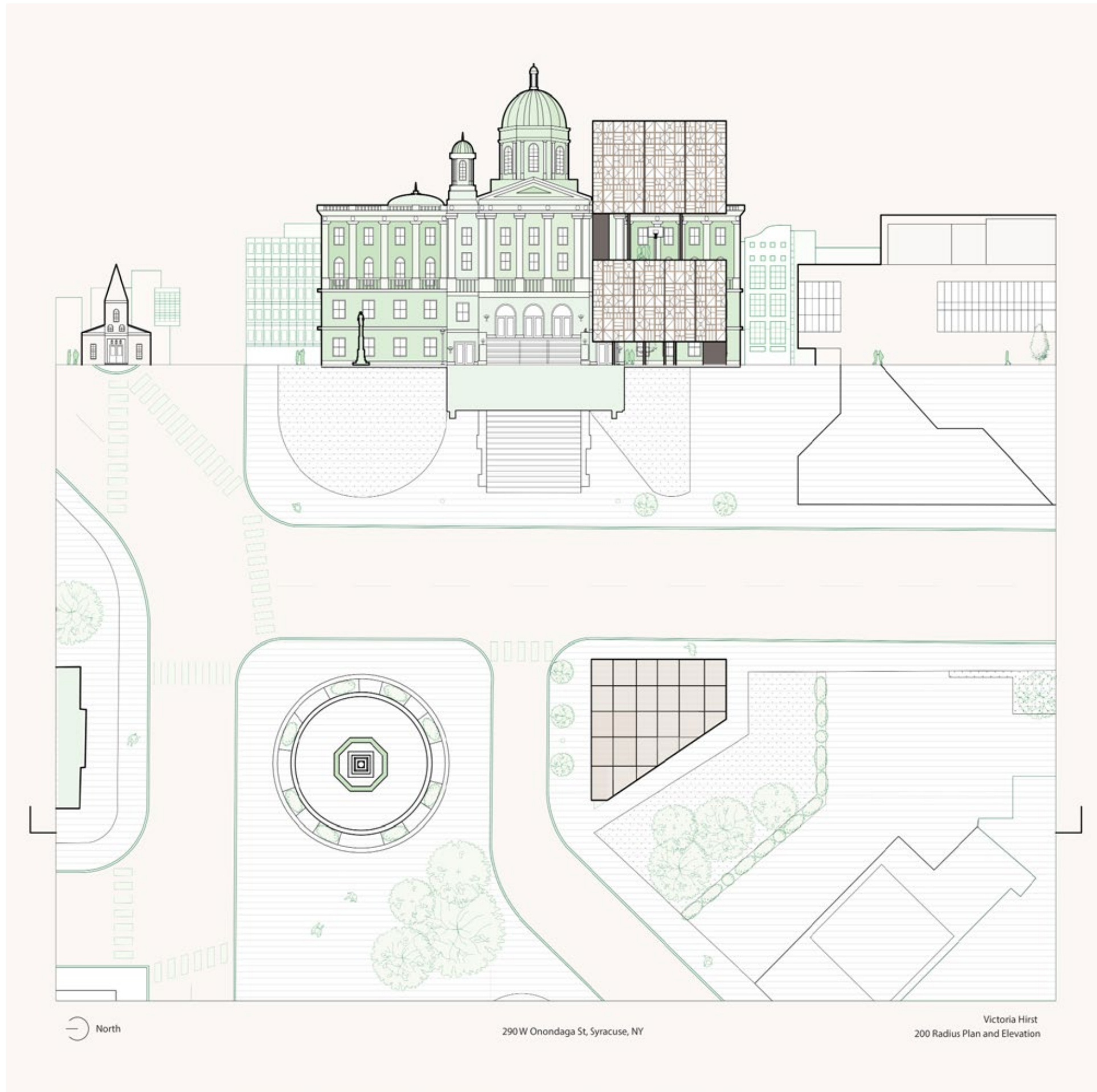

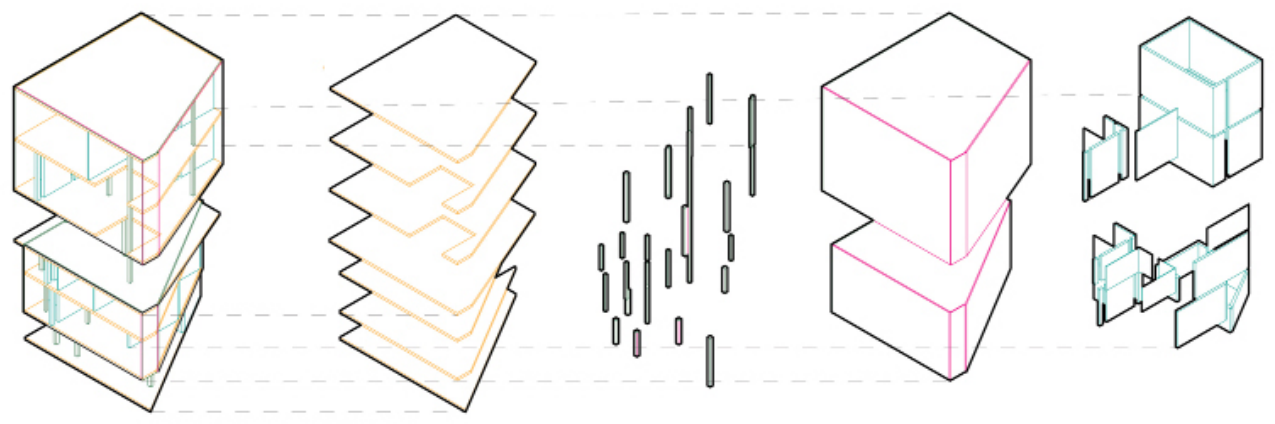
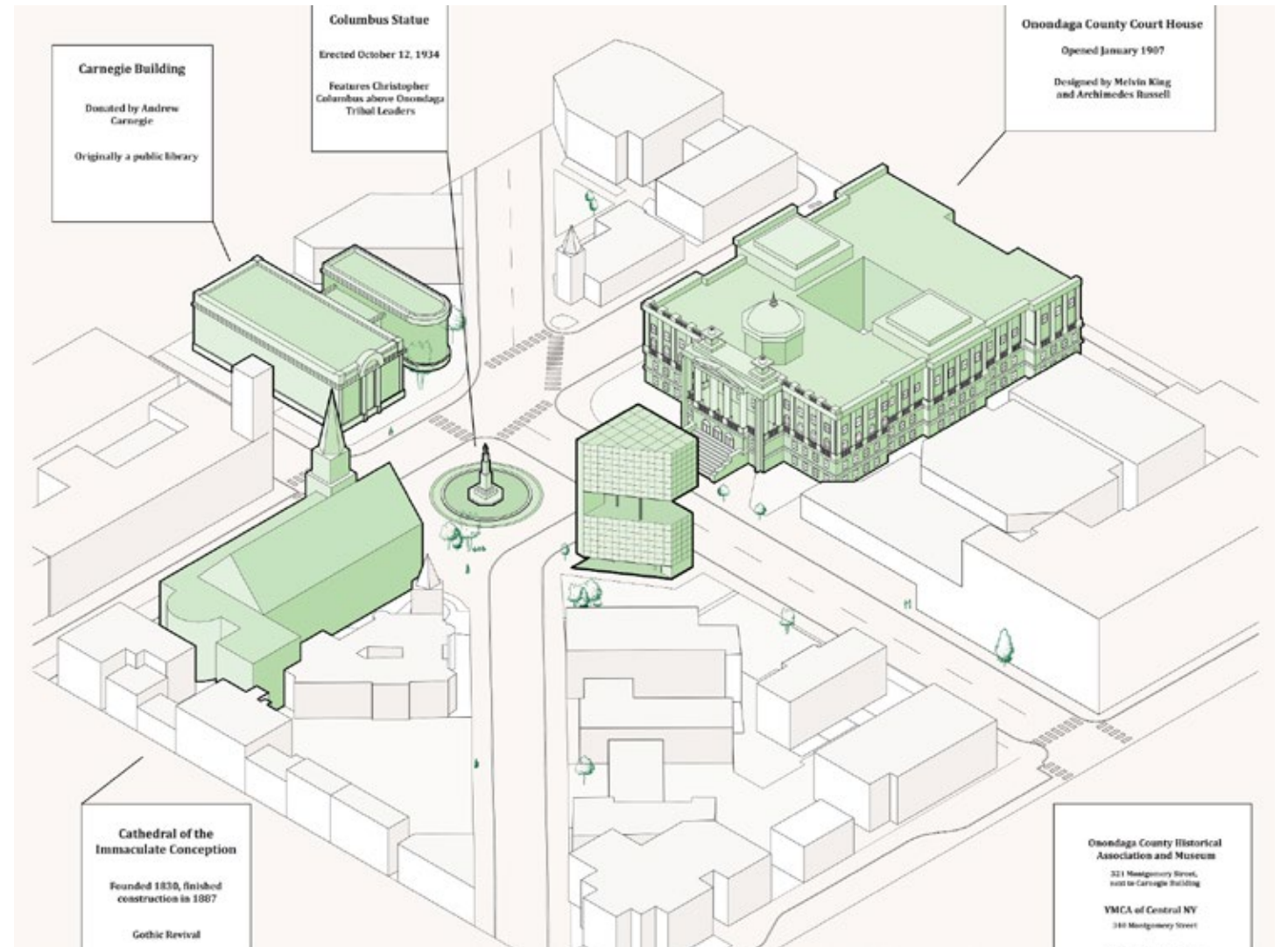
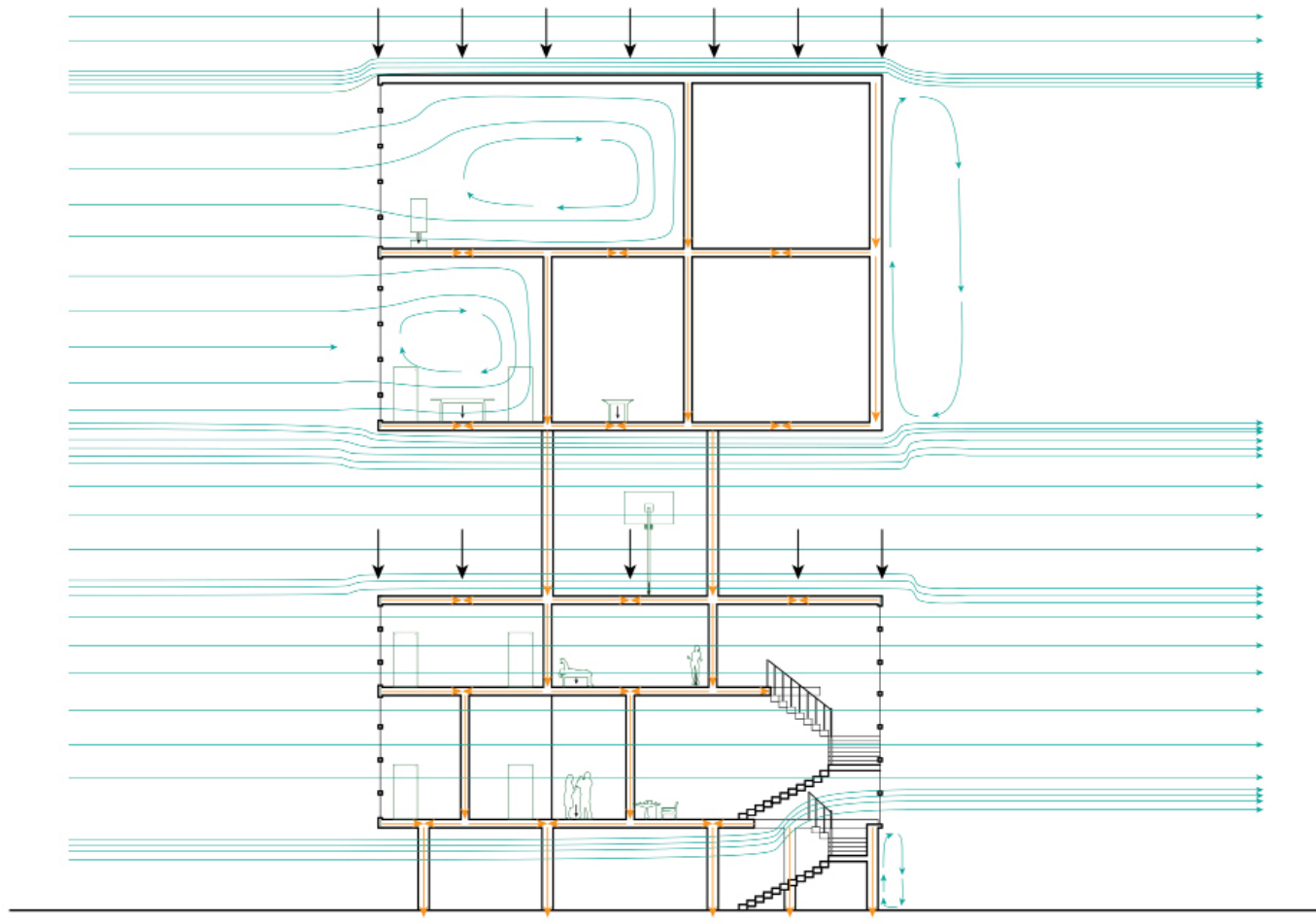

Structure Hierarchy

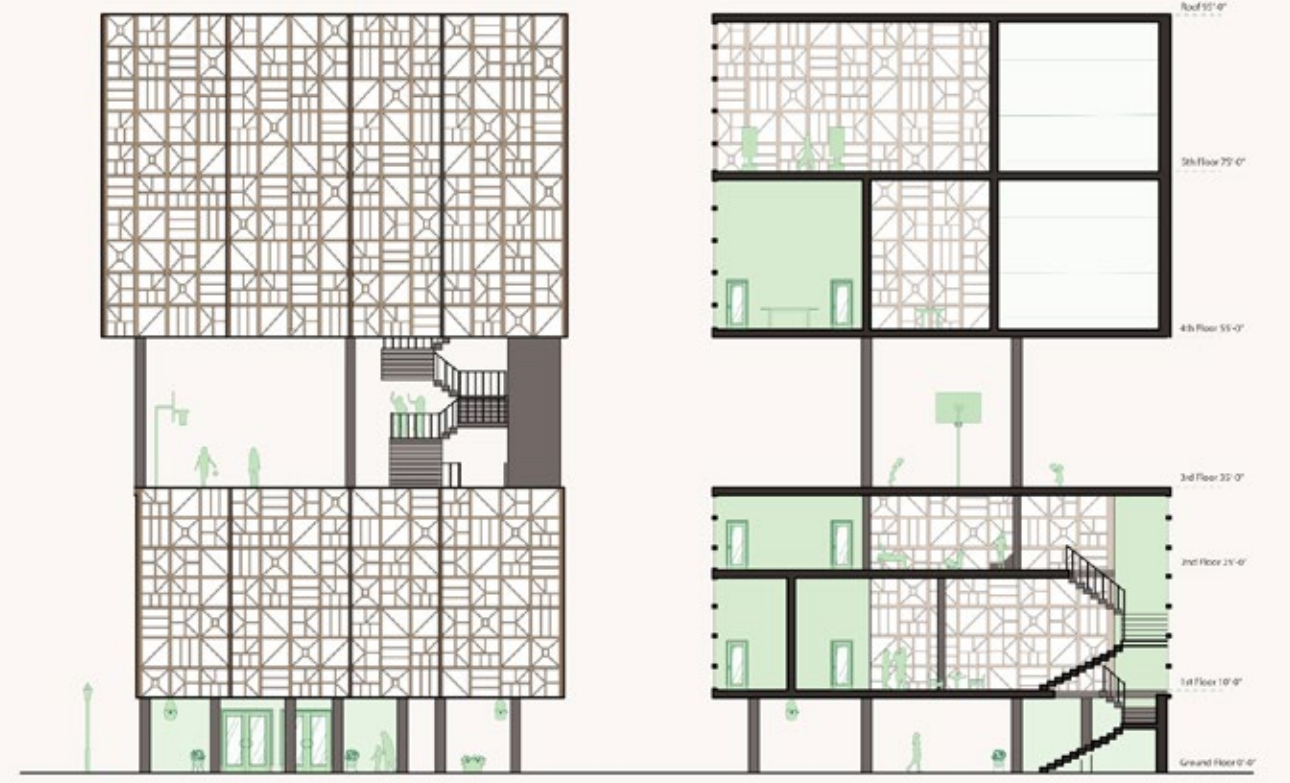

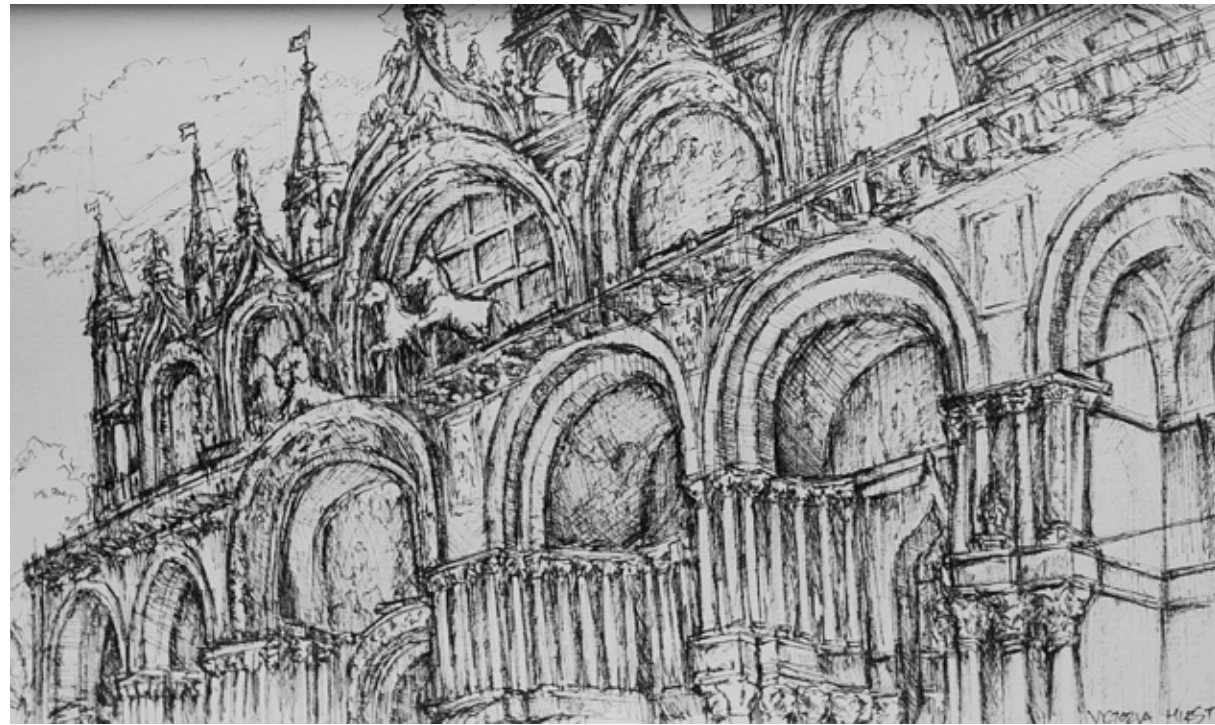

Sketch Paper, Pigma Micron Pen

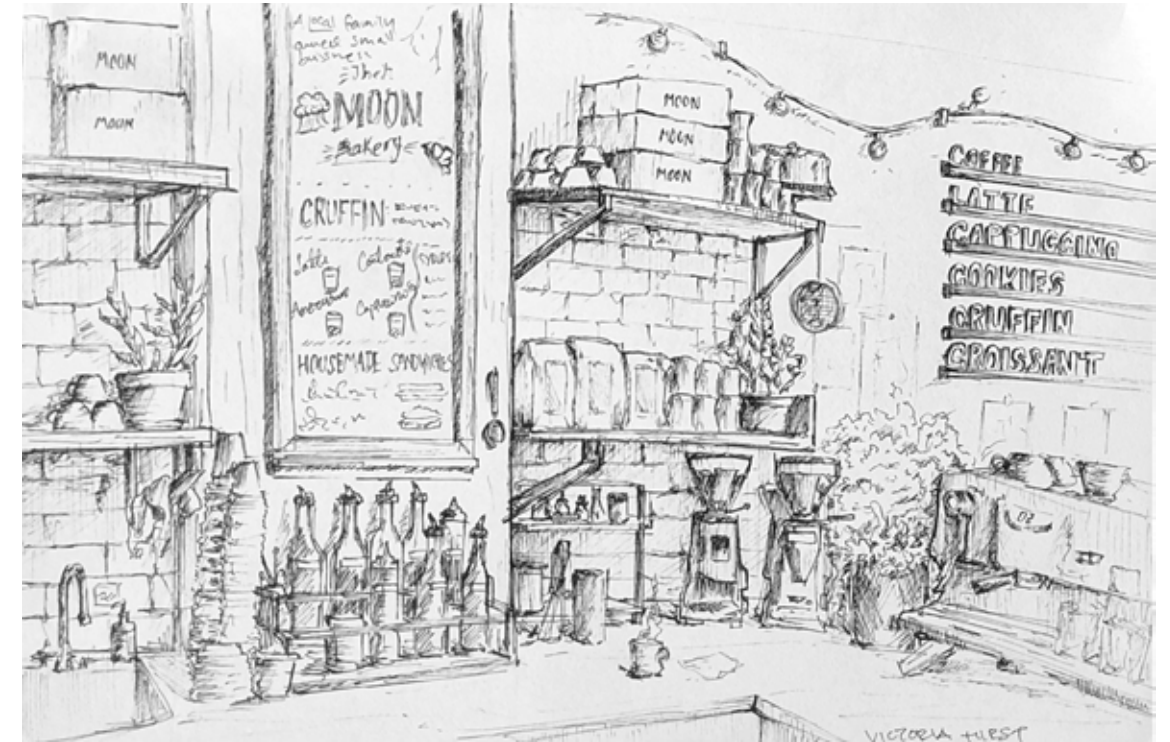

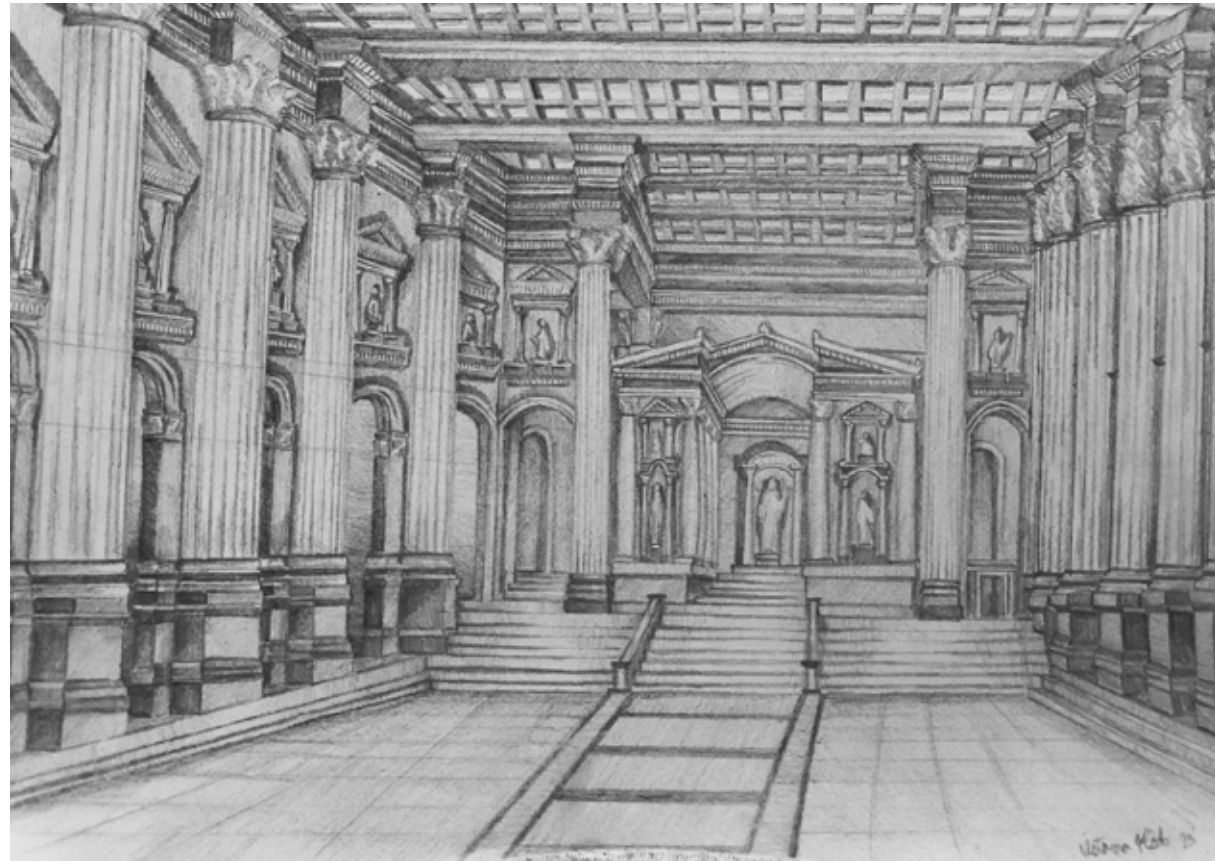

Tan Sketch Paper, Graphite Pencils





Olympus XA Pocket Camera, Kodak Gold 35mm

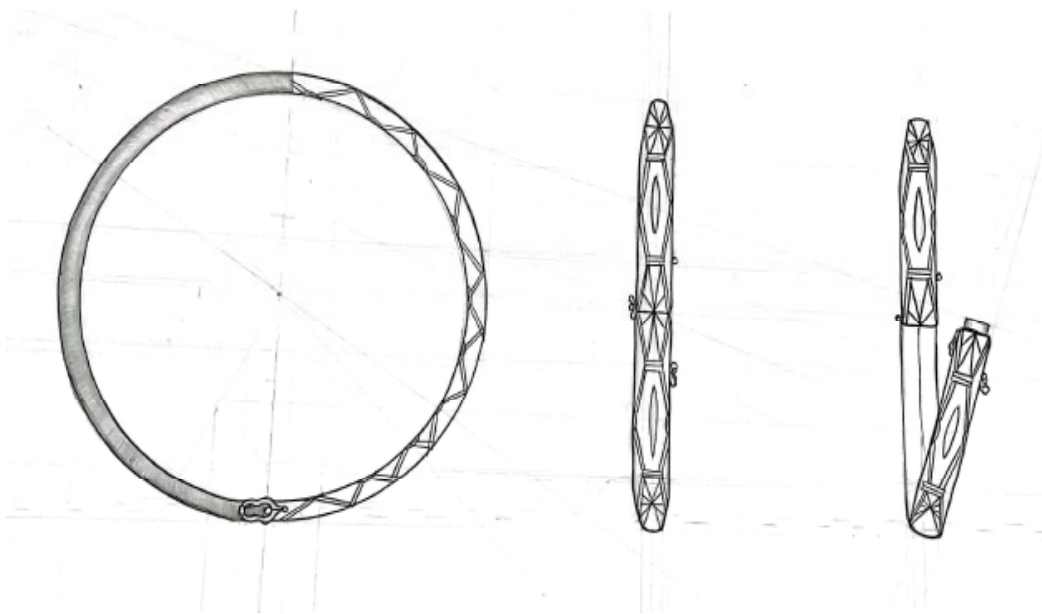

VICTORIA HIRST

T: (916)-708-4233

E: vhirst17@gmail.com